

THIS COPY IS PROVIDED ON A RESTRICTED BASIS AND IS NOT TO BE USED IN ANY WAY DETRIMENTAL TO THE INTERESTS OF PANDUIT CORP.

PART NUMBER		TAB SIZE	WIRE RANGE AWG (mm ²)	DIMENSIONS		HOUSING COLOR	TOOL CHART RECOMMENDED PRESSES CP-861, CP-860 CP-851, CP-862 CA-800/CA9 DIE INSERTS
PREFIX	PK			A ^{±.030}	B ^{MAX}		
DNF18-250M	-3K	.250 X .032 (6.3 X 0.8)	22-18 (0,5-1,0)	.90 (22,9)	.145 (3,68)	RED	CD-800-1 CA9-1A
DNF14-250M	-3K	.250 X .032 (6.3 X 0.8)	16-14 (1,5-2,5)	.90 (22,9)	.162 (4,11)	BLUE	CD-800-2 CA9-2A
DNF10-250M	-2K	.250 X .032 (6.3 X 0.8)	12-10 (4,0-6,0)	.95 (24,1)	.225 (5,72)	YELLOW	CD-800-3 CA9-3B

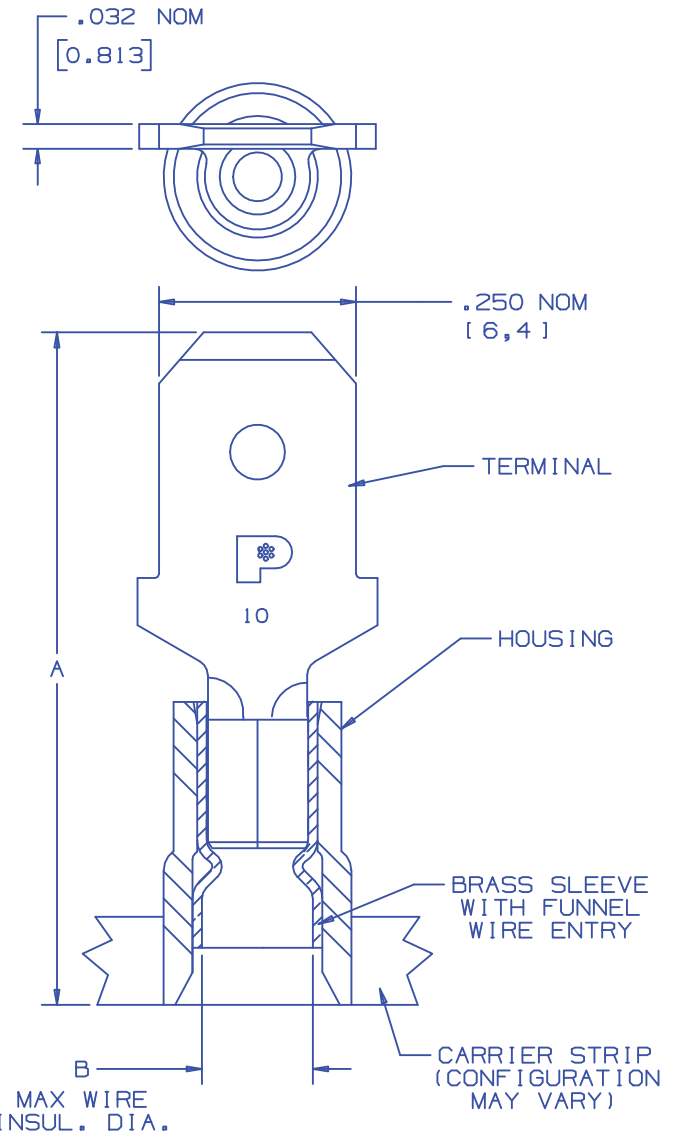

NOTES:

- USED FOR:
 - A. 600V MAX. VOLTAGE RATING.
 - B. 105° C (221°F) MAX. TEMP. RATING
 - C. STRANDED COPPER WIRE ONLY.
- PACKAGE QTY:
 - 3K = 3000 PC. REEL
 - 2K = 2000 PC. REEL
- MATERIAL:
 - A. STAMPING: COPPER, NICKEL PLATED
 - B. HOUSING: TYPE 6/6 NYLON
- WIRE STRIP LENGTH: $9/32 \begin{matrix} +1/32 \\ -0 \end{matrix}$ (7.1 $\begin{matrix} +.8 \\ -0 \end{matrix}$) (DNF18-250M & DNF14-250M)
- $: 11/32 \begin{matrix} +1/32 \\ -0 \end{matrix}$ (8.7 $\begin{matrix} +.8 \\ -0 \end{matrix}$) (DNF10-250M)
- DIMENSIONS IN BRACKETS ARE IN mm OR mm².



CERTIFIED
LR31212
(EXCEPT
DNF10-250M)

A41533_05

05	11/04	KLFU		ADDED LOGO AND MARKING 10 WIRE RANGE 4,0 WAS 2,5							TINLEY PARK, ILLINOIS		
04	1/01	RM	SKB	FILESPEC WAS N41533AA_PCD_03	08933			CCH	JAC				
03	10/98	JKD		MATERIAL WAS TIN PLATED ADDED CP-862, CA9	07836					REELSMART™, DISCO™, NYLON BARREL INSULATED MALE DISCONNECTS (.250 X .032 TAB SIZE)			
02	2/96	ED	RS	REVISED NOTES AND TABLE SPEC.S FILESPEC WAS: NPC_A41533_01	04089			DH	LA				
REV	DATE	BY	CHK	DESCRIPTION	ECN #	QA	CUST	PM	APP	DRAWN BY	CHK'D	SCALE	DRAWING NO./CAD FILENAME
										BDK	RLS	NONE	A41533