

## RFELA-5/8X9

902-928MHz - 8dBi Fiberglass Omnidirectional High Gain Outdoor Antenna for LoRa, LoRaWAN / LongFi and ISM applications

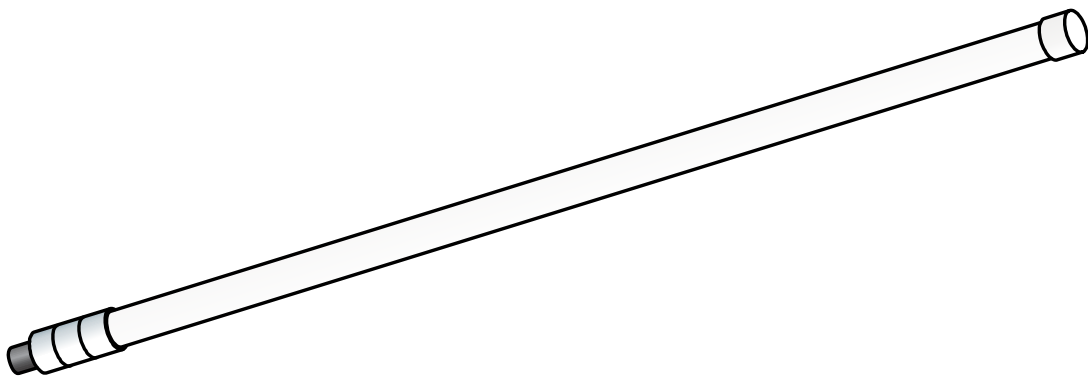

*Fully compatible with technologies, products and services by*



**RF Explorer**<sup>®</sup>

RFELA-5/8X9 8dBi 902-928MHz  
Fiberglass Antenna LoRa/LoRaWAN



Check latest details at [lora.rf-explorer.com](http://lora.rf-explorer.com)

## Features

- ✓ High gain 8dBi for 915MHz band
- ✓ High efficiency vertical polarized monopole
- ✓ Robust hermetic fiberglass construction for outdoor usage
- ✓ Include easy to install mechanical support
- ✓ CE RoHS certified

## Specification

<b>Frequency Range</b>	902-928MHz
<b>Impedance</b>	50Ω
<b>VSWR</b>	1.25 typical < 2 maximum
<b>Gain</b>	8dBi
<b>Efficiency Maximum</b>	82%
<b>Polarization</b>	Linear Vertical
<b>Radiation pattern</b>	360° Omni directional
<b>Connector</b>	Type N Male/Jack
<b>Radiator Material</b>	Copper
<b>Covering Material</b>	Fiber Reinforced Polymer FRP White
<b>Physical length</b>	130 cm
<b>Temperature operation</b>	-30°C to +65°C / -22°F to +150°F
<b>Waterproof</b>	IP65

## Antenna VSWR

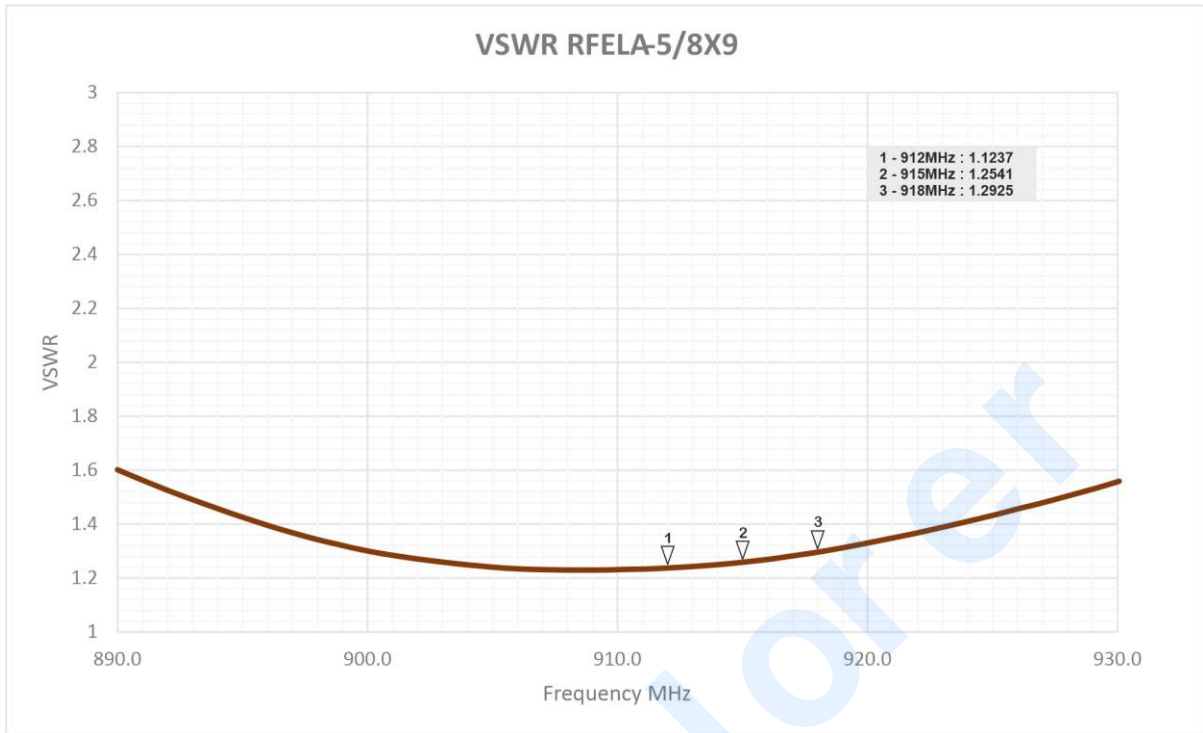

## Antenna Gain

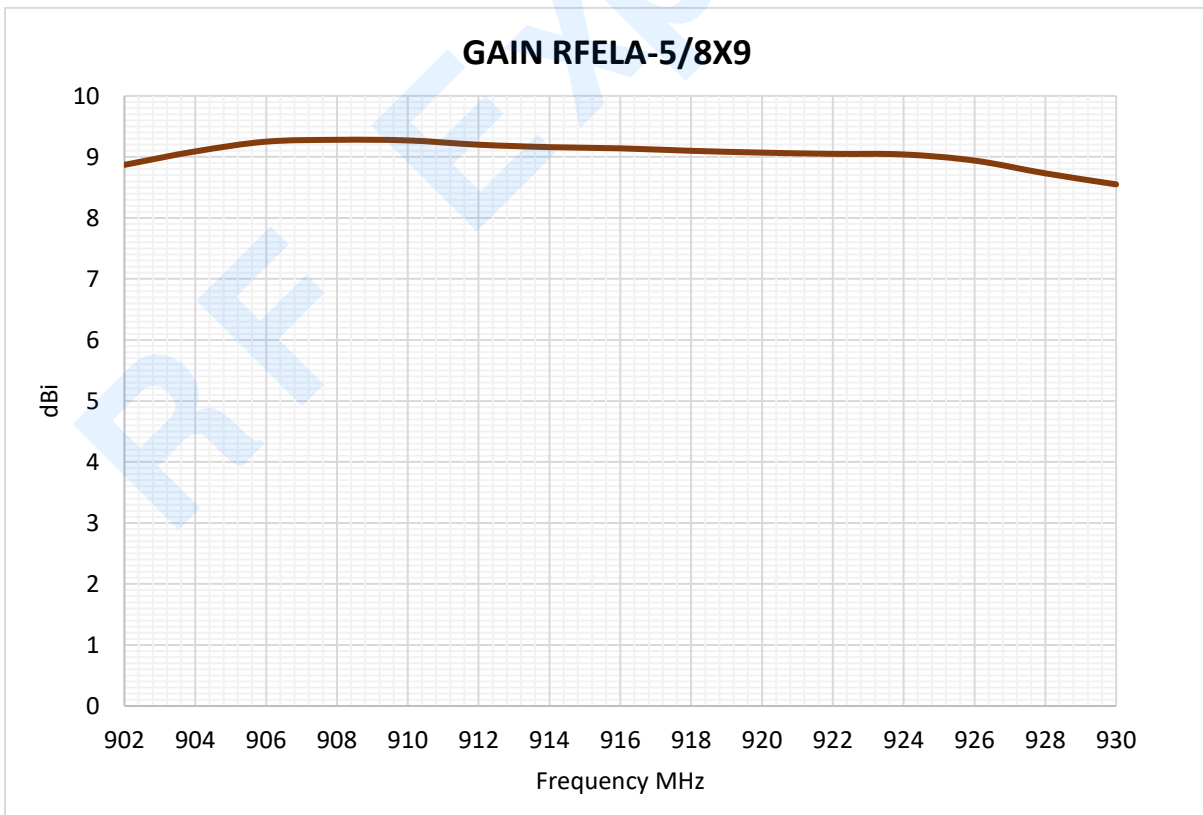

## Antenna Efficiency

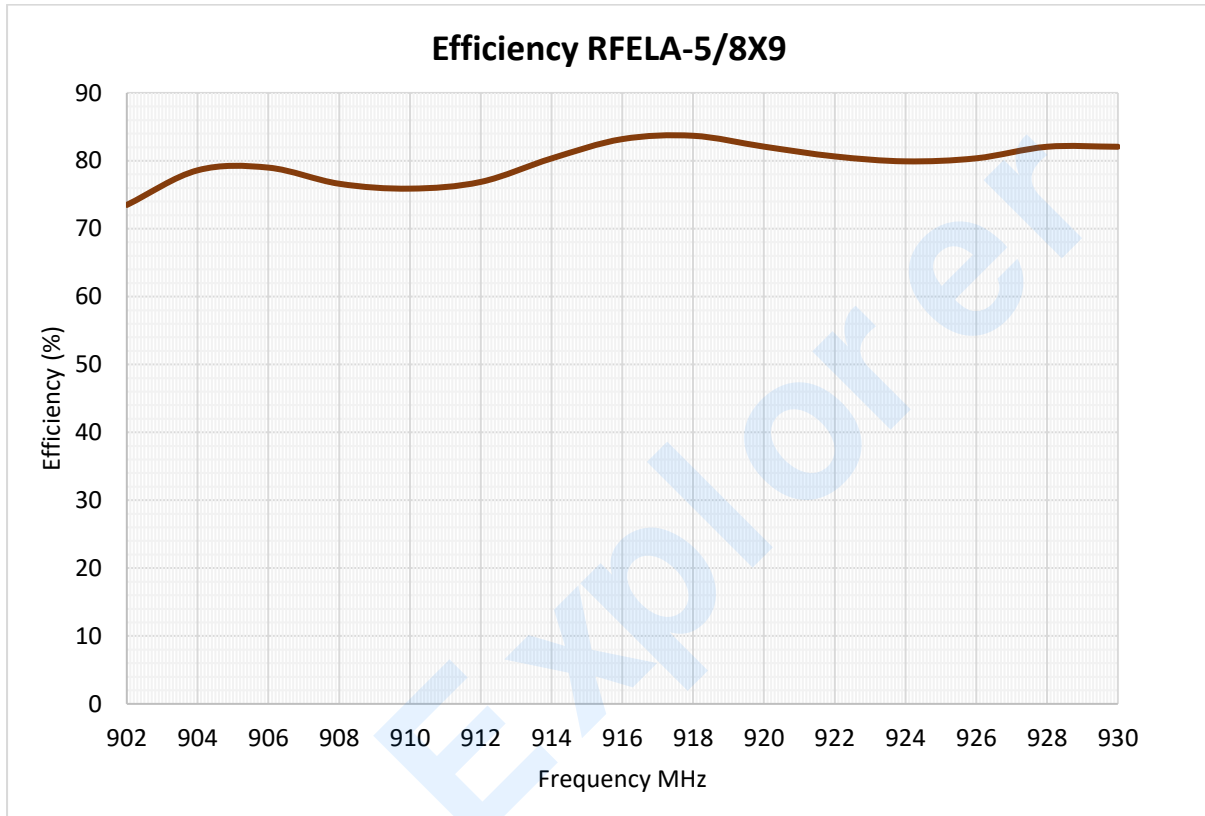

## Antenna Radiation Pattern

Vertical and Horizontal radiation pattern 915MHz center frequency.

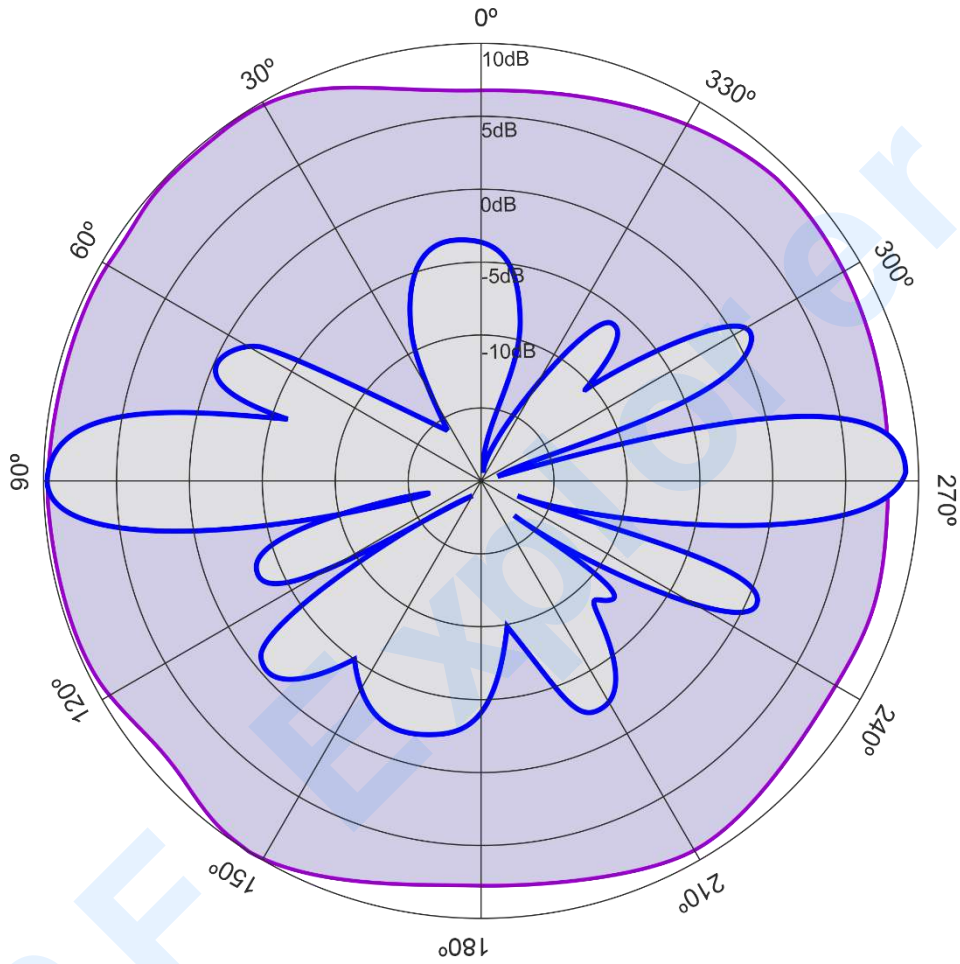

## Antenna Mechanical Specifications

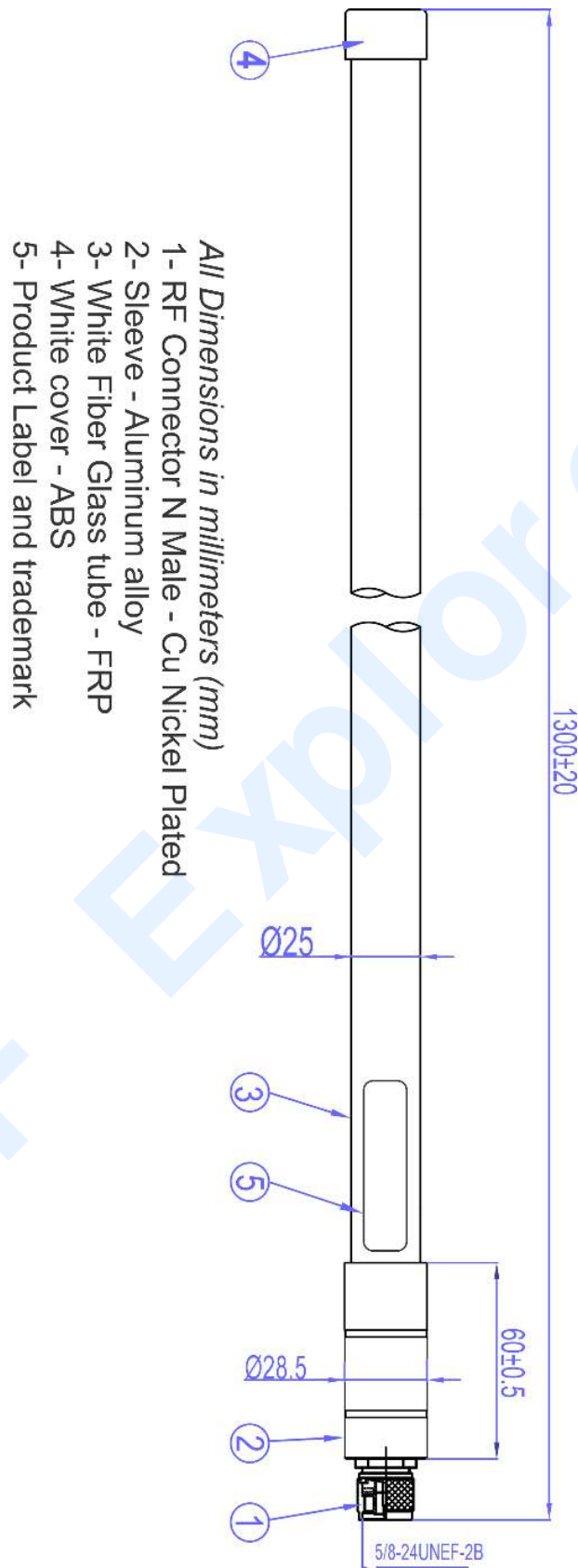

## Antenna Support Mechanical Specifications

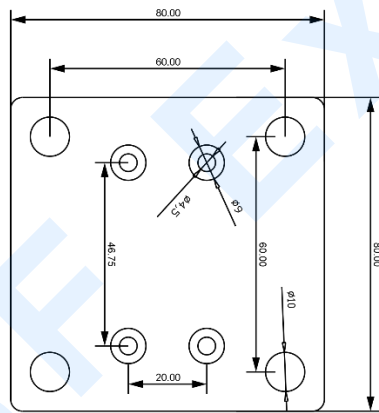
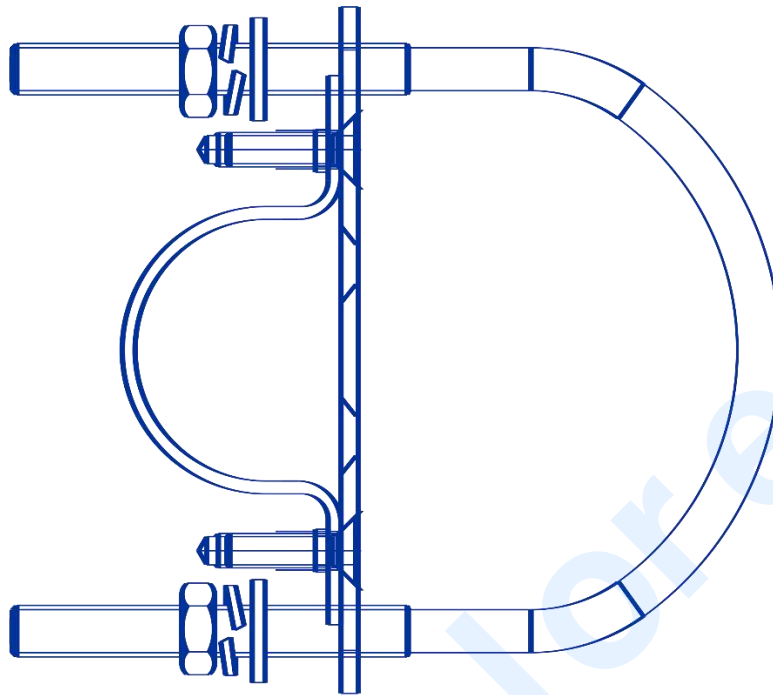

All Dimensions in millimeters (mm)  
Material - Galvanized Iron  
M4 size screws

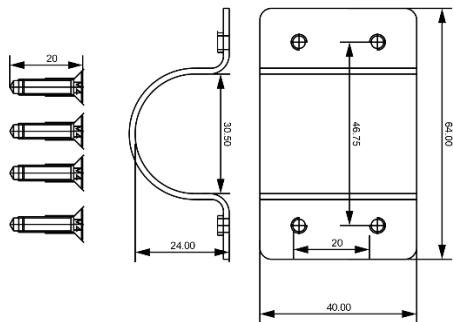
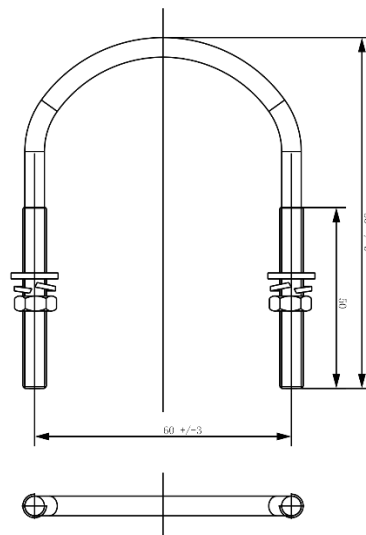

## Included Cable

This antenna model includes a 1m low loss cable, matching the N antenna connector with a RP-SMA Male connector.

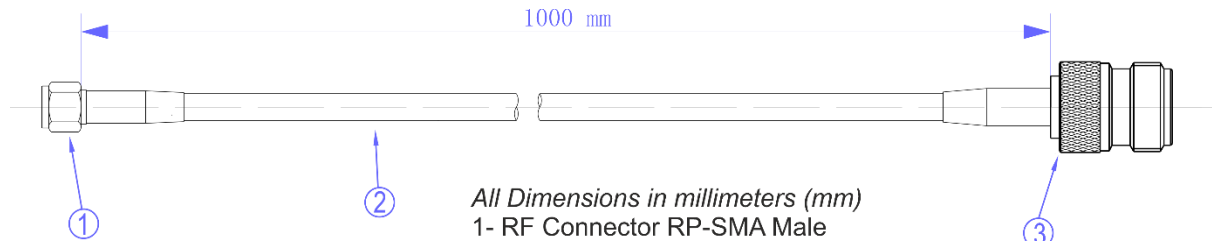

All Dimensions in millimeters (mm)

- 1- RF Connector RP-SMA Male
- 2- CFD200 cable
- 3- RF Connector N Female - Cu Nickel Plated

Structure Figure

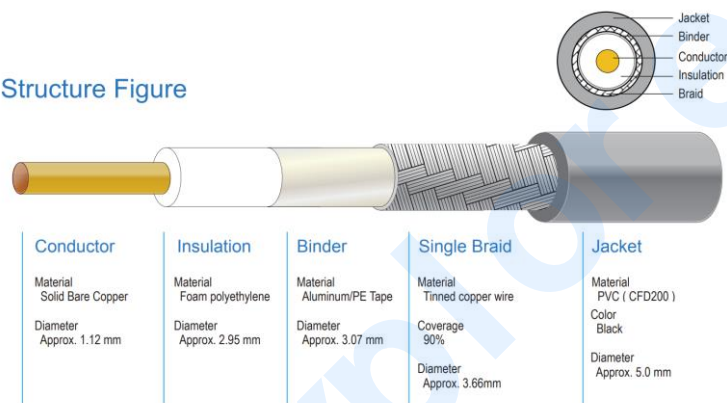

<b>Frequency Range</b>	0-6000MHz
<b>Impedance</b>	50Ω
<b>VSWR</b>	<2.0
<b>Insertion Loss</b>	< 0.5dB @ 900MHz
<b>Insulation Resistance</b>	> 15 MΩ
<b>Voltage Breakdown</b>	> 500V
<b>External Cable Diameter</b>	5mm
<b>Connectors</b>	Type N Female Type RP-SMA Male
<b>Mating Cycles</b>	> 500
<b>Conductor Material</b>	Copper
<b>Binder Material</b>	Aluminum/PE Tape
<b>Braid Material</b>	Tinned copper wire
<b>Operation Temperature</b>	-40°C to +65°C



## Antenna Assembly

This antenna is designed to be assembled over a vertical support in 90° vertical position.

Follow below indications for optimal performance of your antenna setup.

- 1) Install on a clear location with 360 degrees open area, otherwise coverage is lower and signals may be significantly distorted, providing very poor coverage.

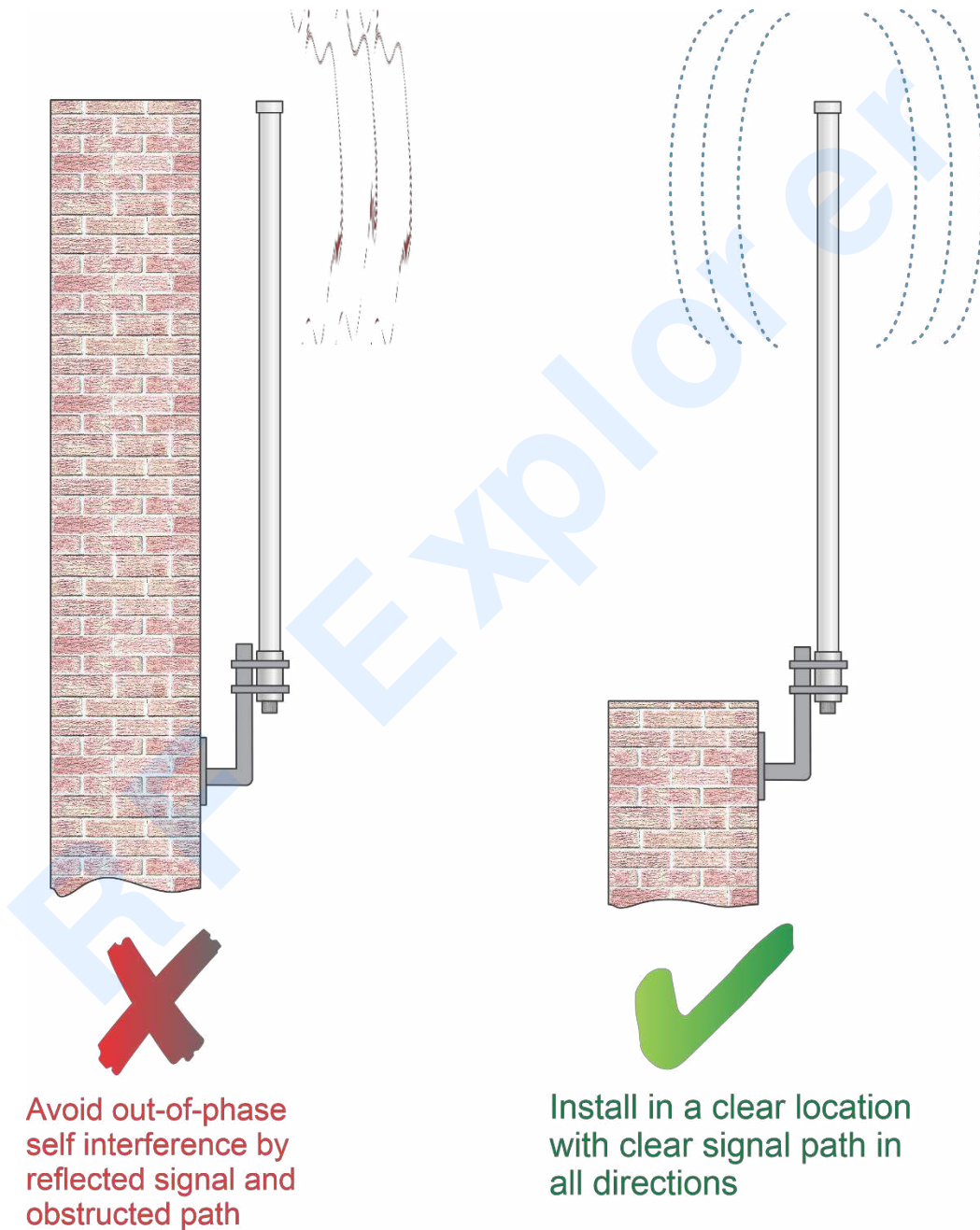

- 2) If the antenna is installed on a location with metallic objects nearby, make sure the antenna is always above such objects and as far as possible. Metallic objects and surfaces negatively impact in antenna VSWR and signal reflections.

3) Provide solid mast assembly using included antenna support



For correct mast/pole assembly, the metallic support must fully contact the metallic antenna support sleeve, not the fiber glass body.

Follow image examples for correct assembly.

4) Use LMR400 quality cables for reduced signal loss and unwanted reflections.

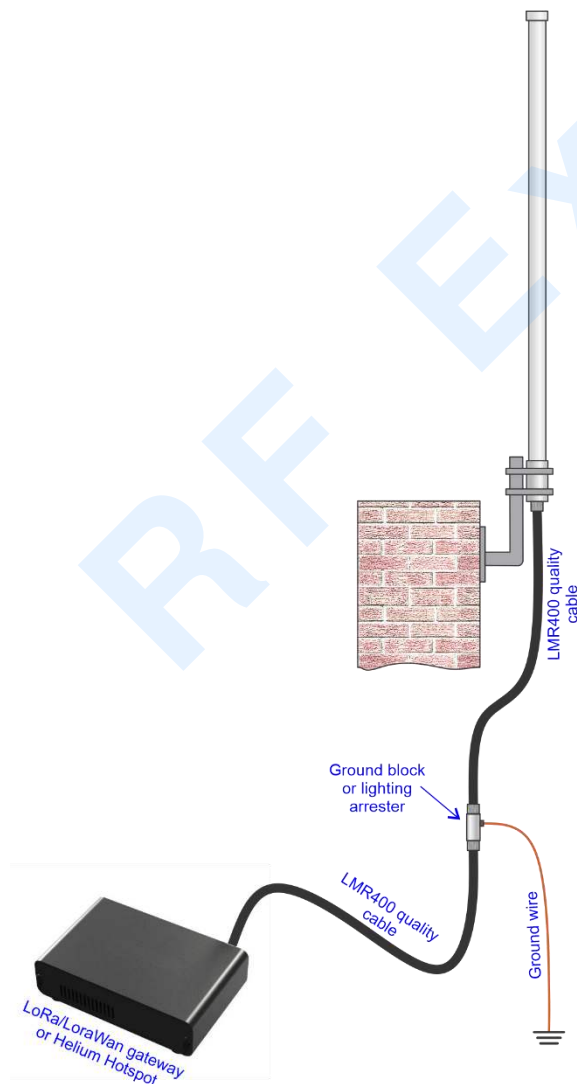

Poor quality RF cables not only reduce signal levels but also distort signals due to out of phase VSWR imbalance.

A ground block or alternatively a lighting arrester should be used to ground antenna in areas where it may be exposed to stormy weather.