

DESCRIPTION

The EV6411-S-00A is an evaluation board for MPMPQ6411, a windowed watchdog timer. It used to reset and monitor the microcontroller. In normal operation, MCU sends trigger signal to MPQ6411 in a defined time window cyclically. A missing or fault trigger signal causes the watchdog to reset the MCU.

MPQ6411 provides a reset signal (low level voltage) to MCU during power-up or under voltage.

By setting the MODE pin to high or low, the watchdog can work as long window mode or short window mode. And the window is programmable.

The EV6411-S-00A is assembled and tested with SOIC8 package.

ELECTRICAL SPECIFICATION

Parameter	Symbol	Value	Units
Input Voltage	V _{CC}	5.0	V

FEATURES

- Windowed watchdog
- Power-on reset during power-up and under voltage
- Programmable short window mode or long window mode
- Watchdog disable function
- Low shutdown mode current
- SOIC8 package

APPLICATIONS

- Automotive Systems
- Industrial Systems

All MPS parts are lead-free, halogen free, and adhere to the RoHS directive. For MPS green status, please visit MPS website under Quality Assurance.

"MPS" and "The Future of Analog IC Technology" are Registered Trademarks of Monolithic Power Systems, Inc.

EV6411-S-00A EVALUATION BOARD



(L × W × H) 3.81cm × 3.81cm × 0.5cm

Board Number	MPS IC Number
EV6411-S-00A	MPQ6411GS

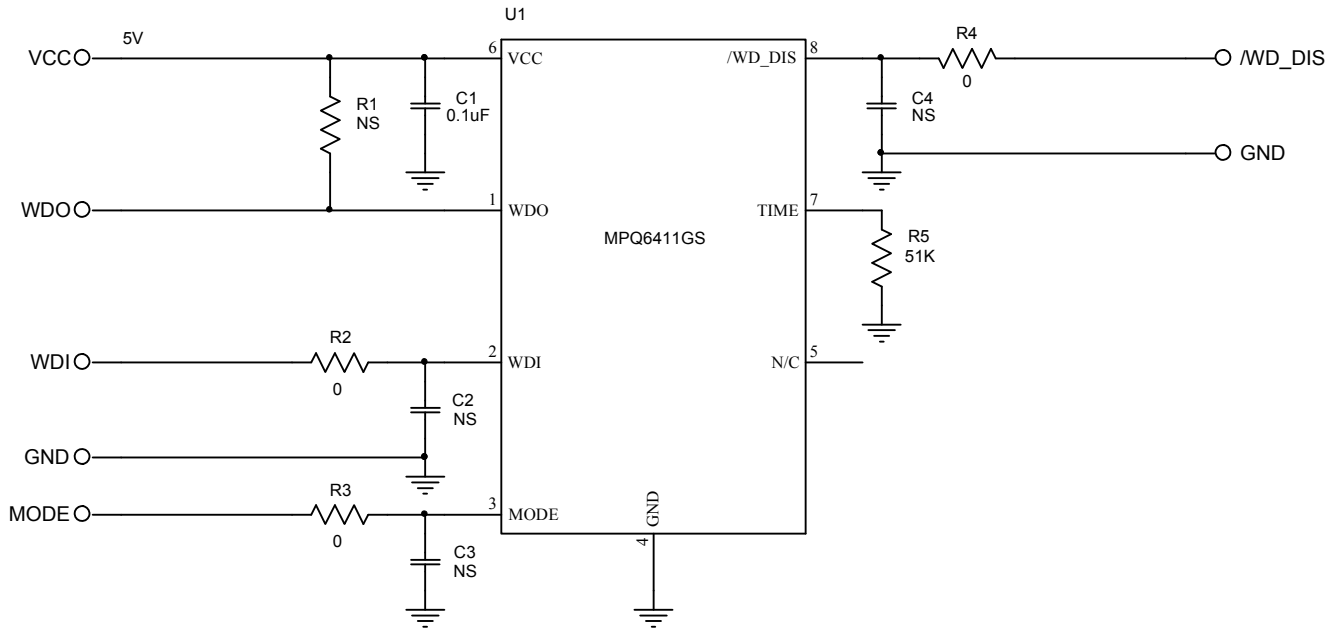
EVALUATION BOARD SCHEMATIC

EV6411-S-00A BILL OF MATERIALS

Qty	Ref	Value	Description	Package	Manufacturer	Part Number
1	C1	0.1µF	Ceramic Cap., 16V, X7R	0603	muRata	GRM188R71C104KA01D
3	C2, C3, C4	NS				
1	R1	NS				
3	R2, R3, R4	0	Film Resistor;5%	0603	Yageo	RC0603JR-070RL
1	R5	51K	Film Resistor;1%	0603	Yageo	RC0603FR-0751KL
1	U1			SOIC8	MPS	MPQ6411GS

EVB TEST RESULTS

Performance waveforms are tested on the evaluation board.

$V_{CC} = 5V$, $T_A = 25^{\circ}C$, unless otherwise noted.

Power on Reset and No Signal

Mode=0V, WDI=3V

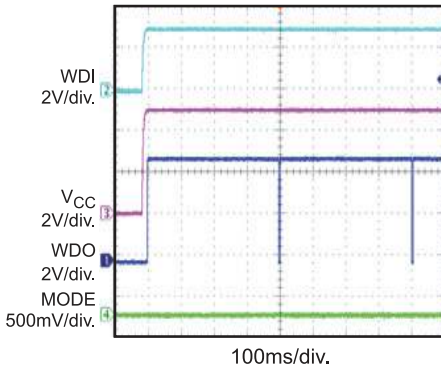

Sync&No Triggered Signal

Mode=0V, WDI_OK=500 μ s, WDI Period=1s

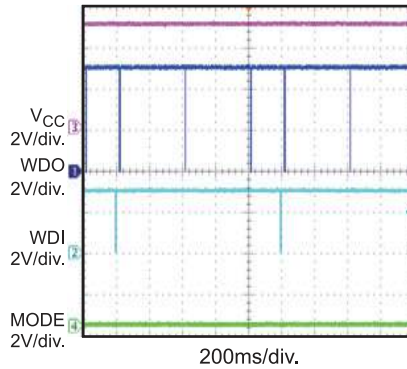

Sync&Triggered in Open Window

Mode=0V, WDI_OK=500 μ s, WDI Period=21ms

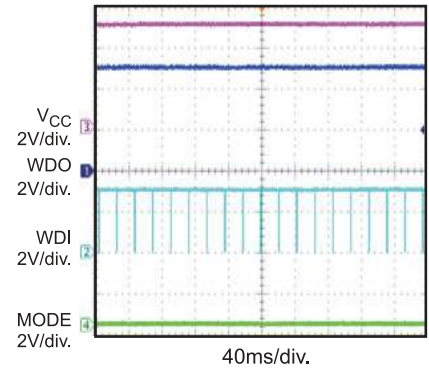

Sync&Triggered in Close Window

Mode=0V, WDI_OK=500 μ s, WDI Period=3.5ms

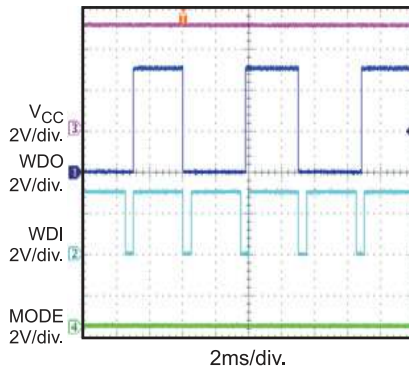

Power on Reset and No Signal

Mode=3V, WDI=3V, WDI Period=5s

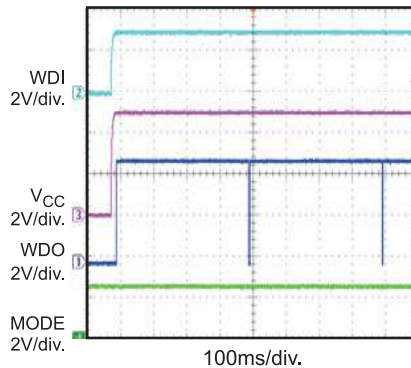

Sync&No Triggered Signal

Mode=3V, WDI_OK=500 μ s, WDI Period=5s

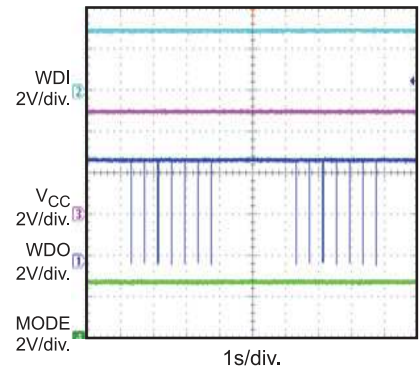

Sync&Triggered in Open Window

Mode=3V, WDI_OK=500 μ s, WDI Period=2.2s

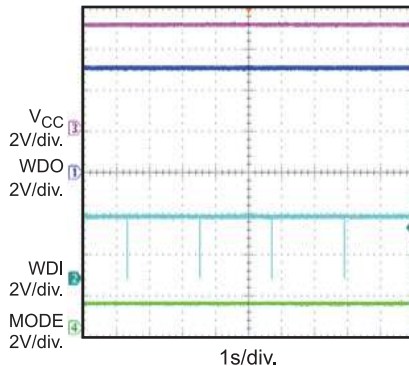

Sync&Triggered in Close Window

Mode=3V, WDI_OK=500 μ s, WDI Period=3.6ms

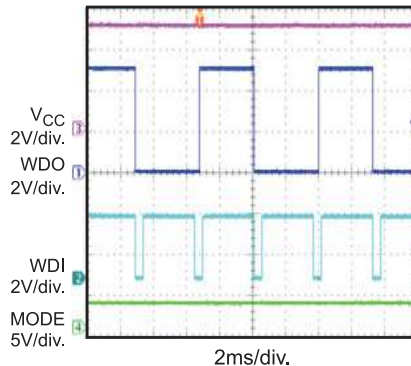

EVB TEST RESULTS (continued)

Performance waveforms are tested on the evaluation board.

$V_{CC} = 5V$, $T_A = 25^{\circ}C$, unless otherwise noted.

Long Close Mode to Short Close Mode

WDI_OK=500 μ s, WDI Period=200ms

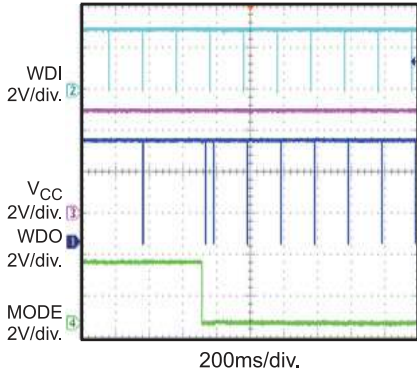

Short Close Mode to Long Close Mode

WDI_OK=500 μ s, WDI Period=10ms

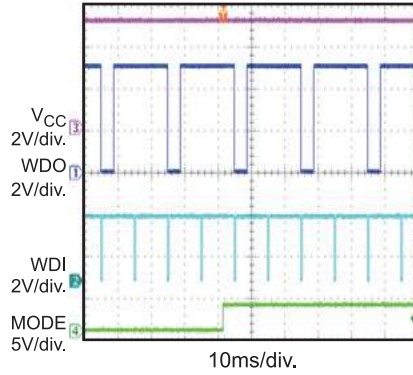

Long Open Mode to Short Close Mode

WDI_OK=500 μ s, WDI Period=2s

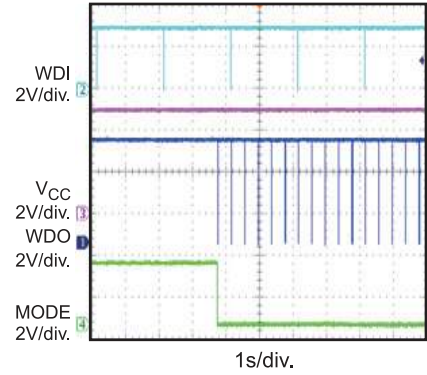

Long Open Mode to Short Close Mode

WDI_OK=500 μ s, WDI Period=20ms

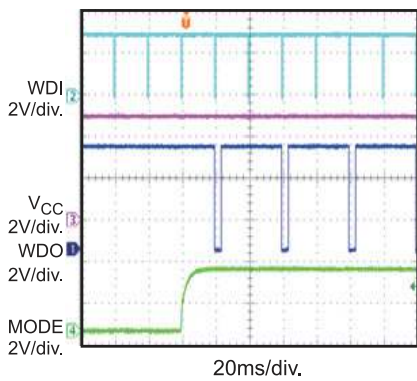

PRINTED CIRCUIT BOARD LAYOUT

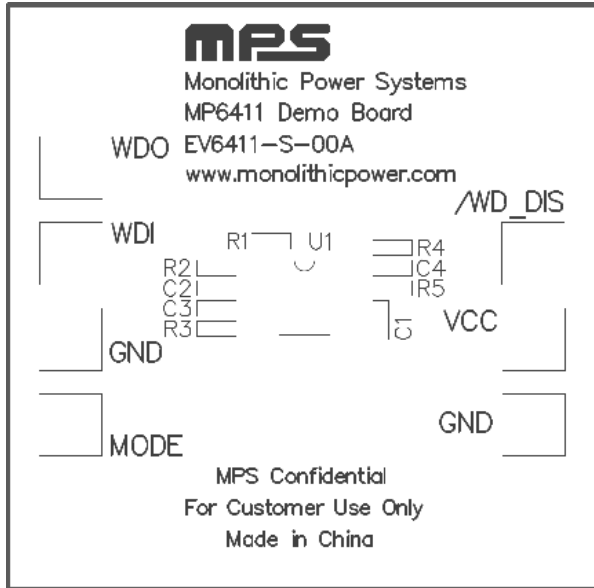

Figure 1: Top Silkscreen Layer

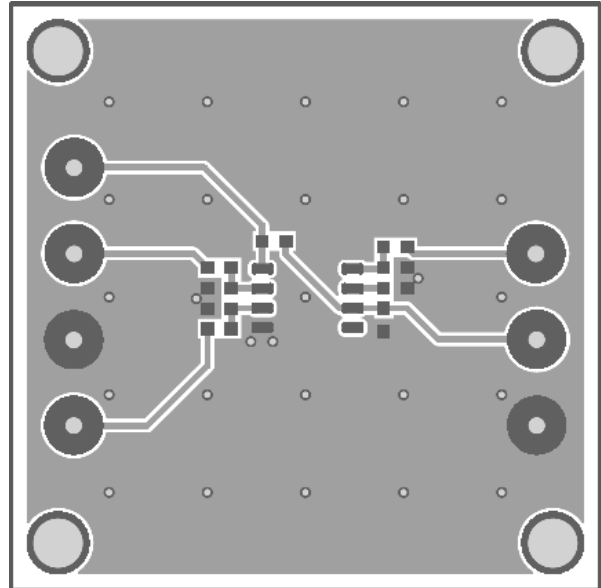

Figure 2: Top Layer

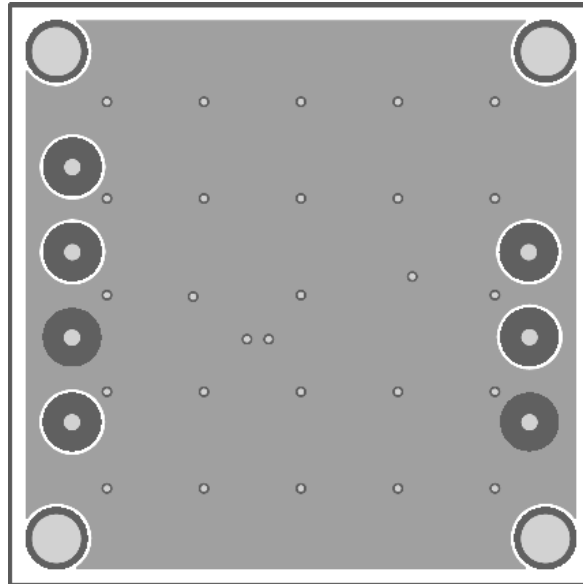

Figure 3: Bottom Layer

QUICK START GUIDE

1. Set the VCC to 5V ($\pm 10\%$).
2. Drive the /WD-DIS pin higher than 3.2V to enable the watchdog function, set the pin lower than 0.8V to disable the watchdog. Float this pin to turn on the watchdog.
3. Connect the WDI and WDO pin to MCU to receive the trigger signal and output reset signal respectively.
4. Use R5 to set the time-out. For R5=51k Ω , the period of timer T can be determined by:

$$T(\mu\text{s}) = 15.75 * R_5(k\Omega) + 73.5$$

5. To choose the window mode, apply a digital input to the MODE pin, Drive MODE higher than 3.2V to go to long window mode, drive MODE less than 0.8V to work as the short window mode. Float this pin to make the watchdog work as the long window mode.

NOTICE: The information in this document is subject to change without notice. Please contact MPS for current specifications. Users should warrant and guarantee that third party Intellectual Property rights are not infringed upon when integrating MPS products into any application. MPS will not assume any legal responsibility for any said applications.