

Specification Status: RELEASED

GENERAL DESCRIPTION

Littelfuse PolyZen devices are polymer enhanced, precision Zener diode. They offer resettable protection against multi-Watt fault events without the need for multi-Watt heat sinks.

PolyZen Zener diode was selected due to its relatively flat voltage vs current response. This helps improve output voltage clamping, even when input voltage is high and diode currents are large.



An advanced feature of the PolyZen devices is that the Zener diode is thermally coupled to a resistively non-linear, polymer PTC (positive temperature coefficient) substrate. The PTC substrate is fully integrated into the device, and is electrically in series between V_{IN} and the diode clamped V_{OUT} .

This advanced PTC substrate responds to either extended diode heating or overcurrent events by transitioning from a low to high resistance state, also known as "tripping". A tripped PTC will limit current and generate voltage drop. It helps to protect both the Zener diode and the follow-on electronics and effectively increases the diode's power handling capability.

The polymer enhanced Zener diode helps protect sensitive portable electronics from damage caused by inductive voltage spikes, voltage transients, incorrect power supplies and reverse bias. These devices are particularly suitable for portable electronics and other low-power DC devices.

BENEFITS

- Stable Zener diode helps shield downstream electronics from overvoltage and reverse bias
- Trip events shut out overvoltage and reverse bias sources
- Analog nature of trip events minimizes upstream inductive spikes
- Integrated protection on over current, over voltage, over temperature and ESD
- Minimal power dissipation requirements
- Single component placement

FEATURES

- Overvoltage transient suppression
- Stable V_z vs fault current
- Time delayed, overvoltage trip
- Time delayed, reverse bias trip
- Multi-Watt power handling capability
- Integrated device construction
- RoHS Compliant

TARGET APPLICATIONS

- DC power port protection in portable electronics
- DC power port protection for systems using barrel jacks for power input
- Internal overvoltage & transient suppression
- DC output voltage regulation

TYPICAL APPLICATION BLOCK DIAGRAM

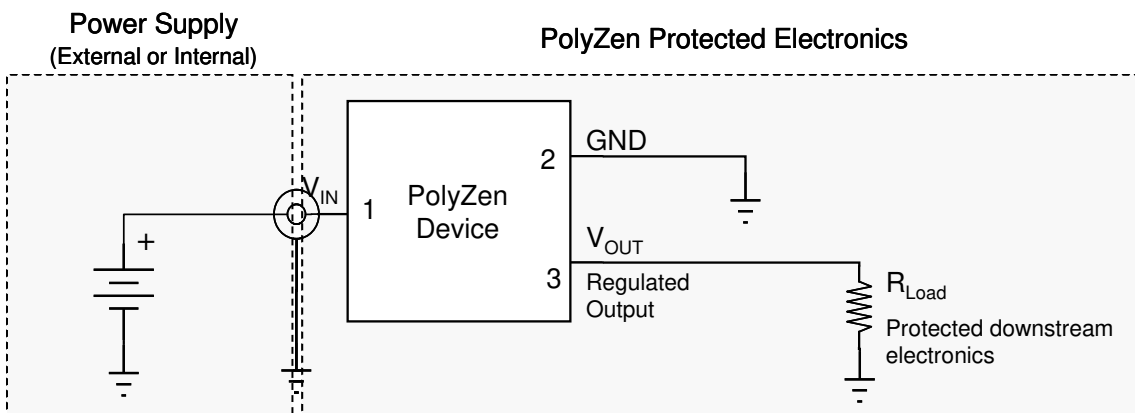

CONFIGURATION INFORMATION

Pin Configuration (Top View)

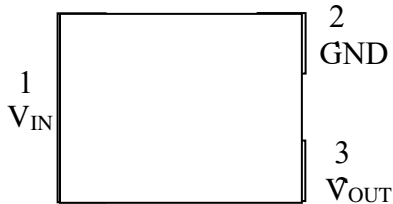

Block Diagram

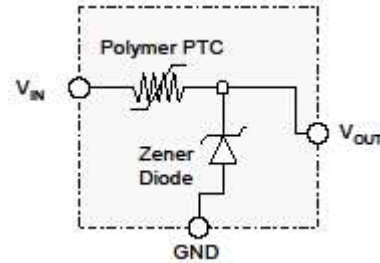

PIN DESCRIPTION

Pin Number	Pin Name	Pin Function
1	V _{IN}	V _{IN} - Device input
2	GND	GND
3	V _{OUT}	V _{OUT} - Zener regulated voltage output

MECHANICAL DIMMENSIONS

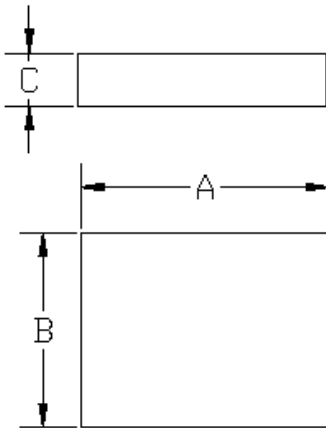

		Min	Typ	Max
		mm (in)		
Length	A	4.80 (0.190)	5.00 (0.197)	5.20 (0.206)
Width	B	3.80 (0.150)	4.00 (0.158)	4.20 (0.166)
Height	C	1.20 (0.047)	1.30 (0.051)	1.40 (0.055)

DEFINITION of TERMS

I _{PTC}	Current flowing through the PTC portion of the circuit
I _{FLT}	RMS fault current flowing through the diode
I _{OUT}	Current flowing out the V _{OUT} pin of the device
Trip Event	A condition where the PTC transitions to a high resistance state, thereby significantly limiting I _{PTC} and related currents.
Trip Endurance	Time the PTC portion of the device remains in a high resistance state.

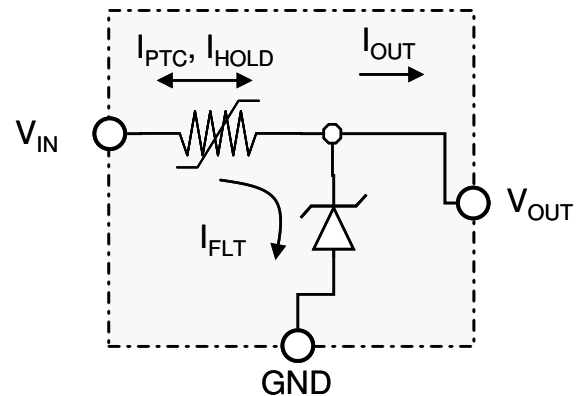

GENERAL SPECIFICATIONS^{1-3, 12} (Typical unless otherwise specified)

ELECTRICAL CHARACTERISTICS

V _Z ⁴ (V)		I _{ZT} ⁴ (A)	Leakage Current		I _{HOLD} ⁵ @20°C (A)	R _{TYP} ⁶ (Ohms)	R _{1Max} ⁷ (Ohms)	V _{INT} Max ⁸ (V)	
Min	Max		Test Voltage (V)	Max Current (mA)				V _{INT} Max (V)	Test Current (A)
5.35	5.85	0.1	5.25	10	2.3	0.040	0.070	16	5

MAXIMUM RATINGS

V _{IN} Max ⁹		I _{FLT} Max ¹⁰		Peak pulse current	ESD withstand (IEC 61000-4-2)		Temperature		Tripped Power Dissipation ¹¹ Max	
V _{IN} Max (V)	Test Current (A)	I _{FLT} Max (A)	Test voltage (V)	8/20 μs pulse (IEC 61000-4-5) (A)	Contact (KV)	Air (KV)	Operating (°C)	Storage (°C)	Value (W)	Test Voltage (V)
20	3	3	16	150	+/- 30	+/- 30	-40 to +85	-40 to +85	1.0	20
-16	-3	-40	-12							

- Note 1: Electrical characteristics determined at 25°C unless otherwise specified.
- Note 2: This device is intended for limited fault protection. Repeated trip events or extended trip endurance can degrade the device and may affect performance to specifications. Performance impact will depend on multiple factors including, but not limited to, voltage, trip current, trip duration, trip cycles, load condition and circuit design. For details or ratings specific to your application contact Littelfuse Connectivity Circuit Protection Division directly.
- Note 3: Specifications developed using 1.0 ounce 0.045" wide copper traces on dedicated FR4 test boards. Performance in your application may vary.
- Note 4: I_{ZT} is the current at which V_Z is measured (V_Z = V_{OUT}). Additional V_Z values are available on request.
- Note 5: I_{HOLD}: Maximum steady state current (current entering or exiting the V_{IN} pin of the device) that will not generate a trip event at the specified temperature. Specification assumes I_{FLT} (current flowing through the Zener diode) is sufficiently low so as to prevent the diode from acting as a heat source. Testing is conducted with an "open" Zener.
- Note 6: R_{TYP}: Resistance between V_{IN} and V_{OUT} pins during normal operation at room temperature.
- Note 7: R_{1Max}: The maximum resistance between V_{IN} and V_{OUT} pins at room temperature, one hour after first tripped event or after reflow soldering.
- Note 8: V_{INT} Max: V_{INT} Max is defined as the maximum voltage at which devices can be survived according to typical qualification process at the specified voltage and current. V_{INT} Max testing is conducted using a "shorted" load (V_{OUT} = 0 V). V_{INT} Max is a survivability rating, not a performance rating. For performance ratings, see Note 2.
- Note 9: V_{IN} Max: For practical application, PolyZen devices are polymer enhanced diode, it use the Polymer PTC technology to offer the diode resettable protection against continuous overvoltage fault events. V_{IN} Max is defined as the maximum voltage rating of the whole device at which devices can be survived according to typical qualification process at specified voltage and current. Testing conducted with no load connected to V_{OUT}. V_{IN} Max is a survivability rating, not a performance rating. For performance ratings, see Note 2.
- Note 10: I_{FLT} Max: Maximum RMS fault current the device can withstand and remain resettable. Specification is dependent on the direction of current flow through the device. RMS fault currents above I_{FLT} Max may permanently damage the PolyZen device. Specification assumes I_{OUT} = 0. Testing conducted with no load connected to V_{OUT}.
- Note 11: The power dissipated by the device when in the "tripped" state, as measured on Littelfuse test boards (see note 3).
- Note 12: Specifications based on limited qualification data and subject to change.

RECOMMENDED PAD DIMENSIONS (mm)

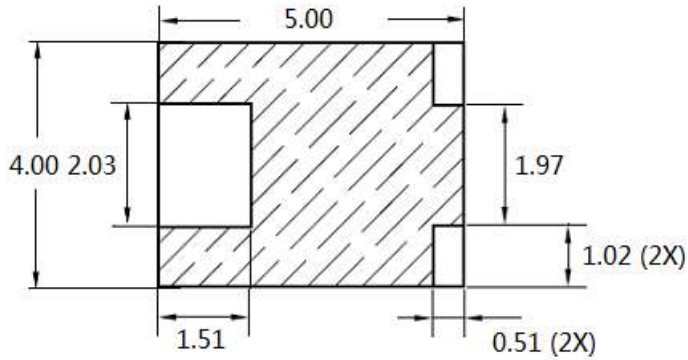

RECOMMENDED PAD LAYOUT (mm)

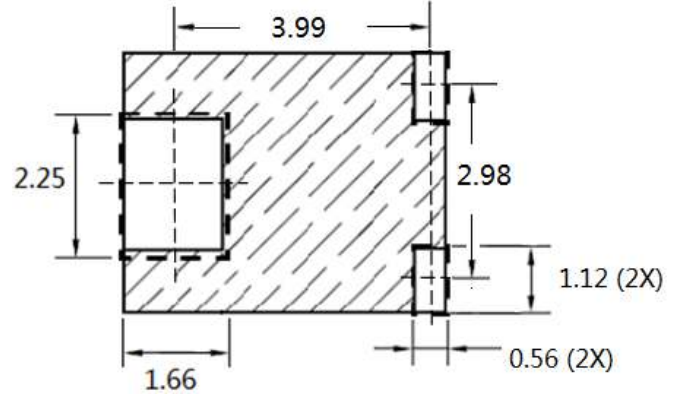

RECOMMENDED SOLDER REFLOW PROFILE

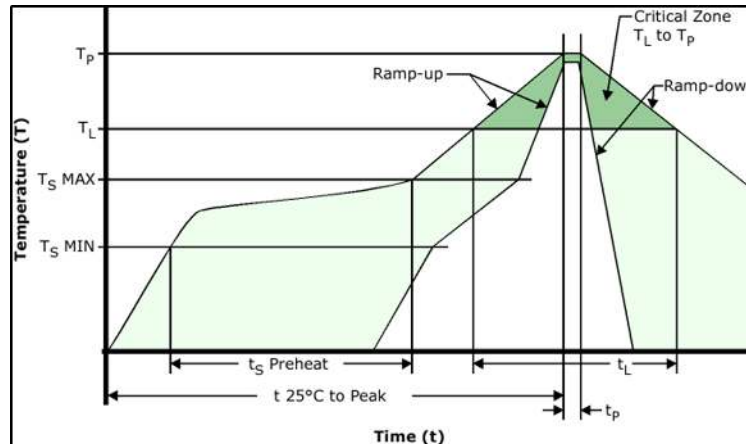

Classification Reflow Profiles	
Profile Feature	Pb-Free Assembly
Average Ramp-up Rate (Ts Max to Tp)	3° C/second max
Average Ramp-down Rate (Tp to TL)	3° C/second max
Preheat	
• Temperature Min (Ts Min)	150° C
• Temperature Max (Ts Max)	200° C
• Time (ts Preheat)	60-180 seconds
Time maintained above:	
• Temperature (TL)	217° C
• Time (tL)	60-150 seconds
Peak / Classification Temperature	
• Temperature (Tp)	250° C
Time within 5° C of actual peak	
• Time (tp)	20-40 seconds
Time 25° C to peak Temperature	8 minutes max

Avoid scratching the package when the device surface temperature is great than 85 °C.



Expertise Applied | Answers Delivered

PolyZen
Polymer Enhanced Zener Diode

PRODUCT: ZEN056V230A16YC

DOCUMENT: SCD28843
REV LETTER: A
REV DATE: JULY 26, 2016
PAGE NO.: 5 OF 8

TYPICAL DEVICE CHARACTERISTICS

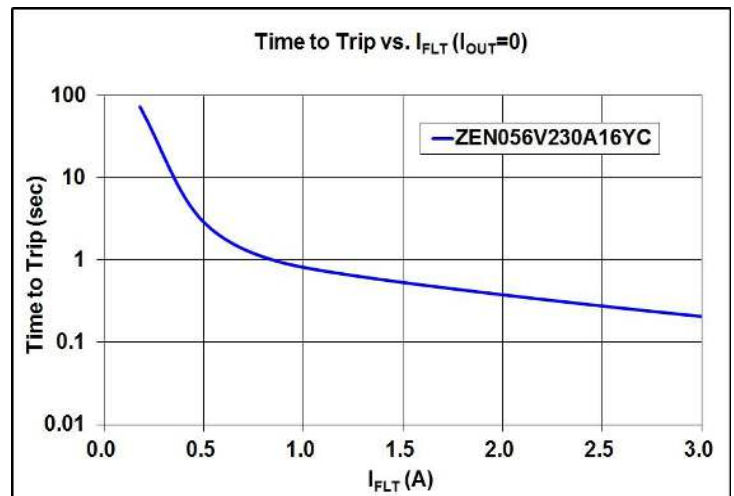
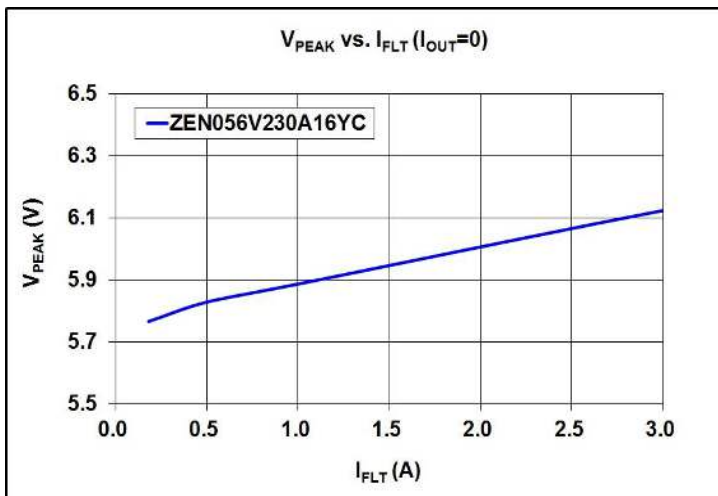
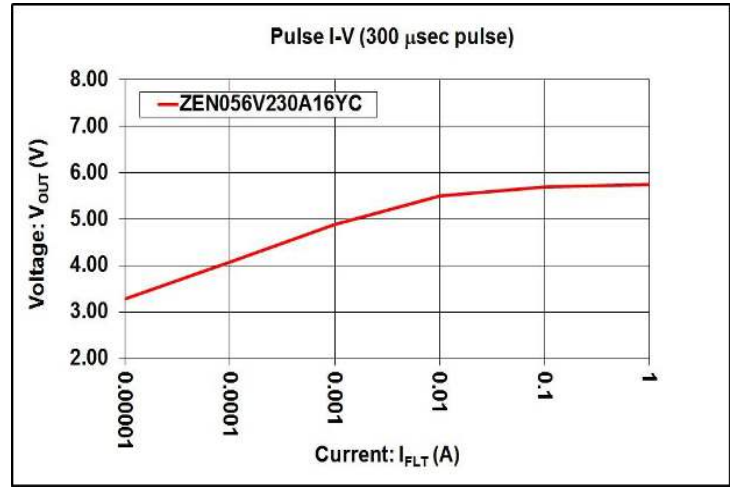
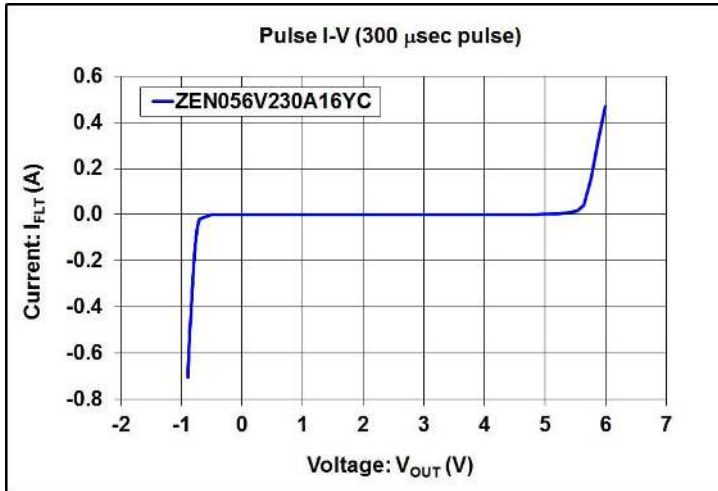
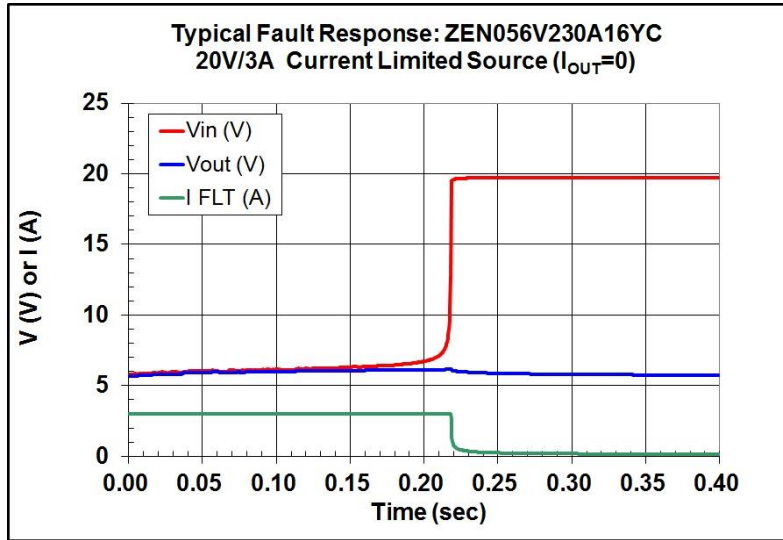

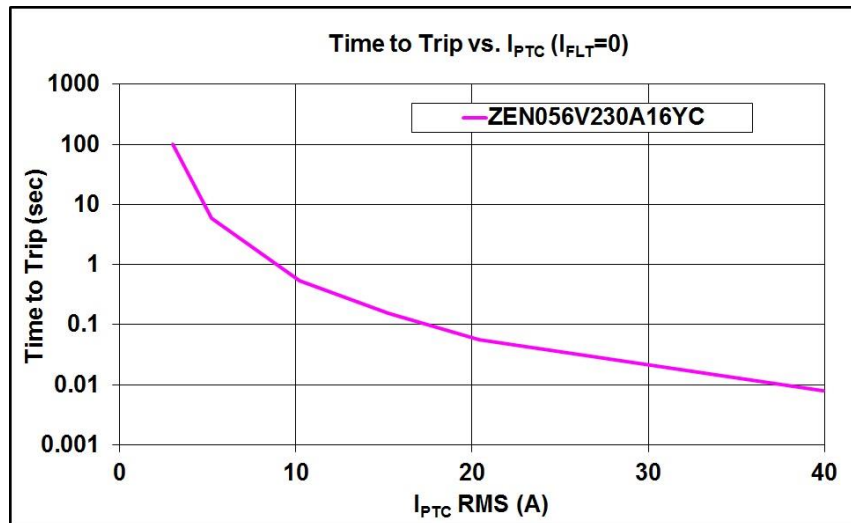
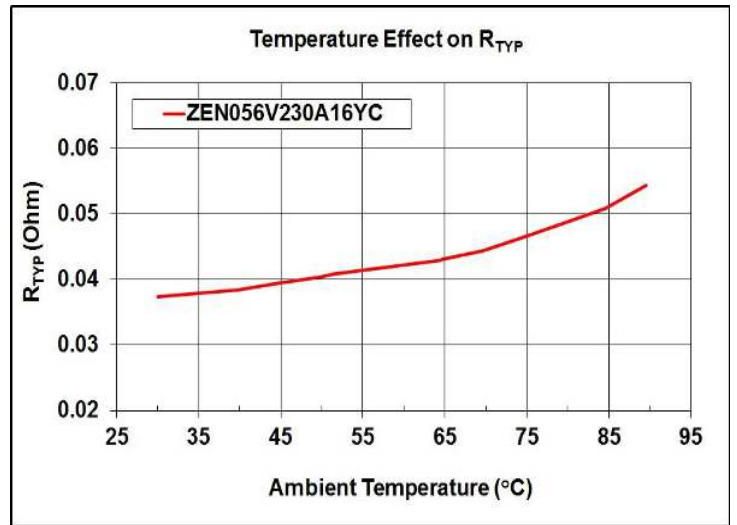
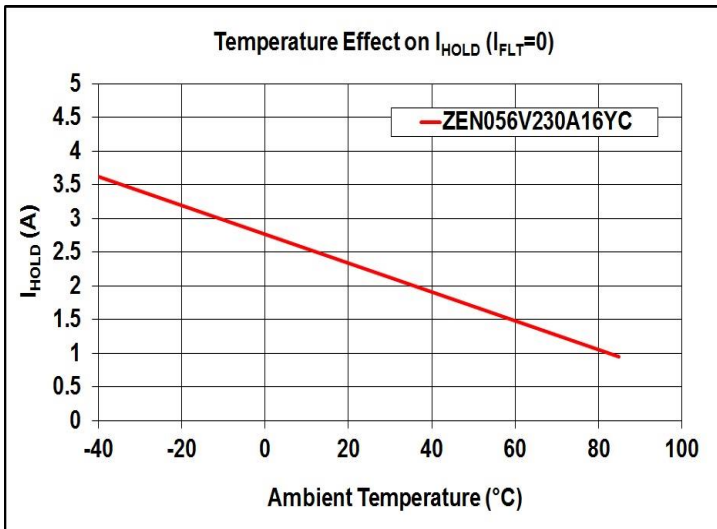
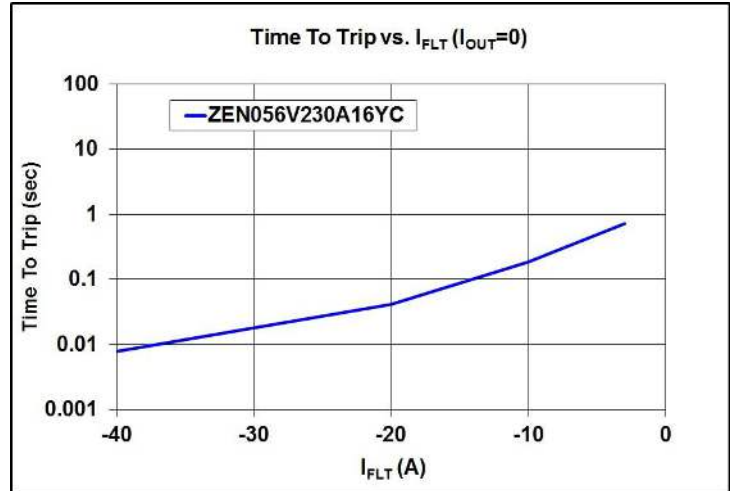
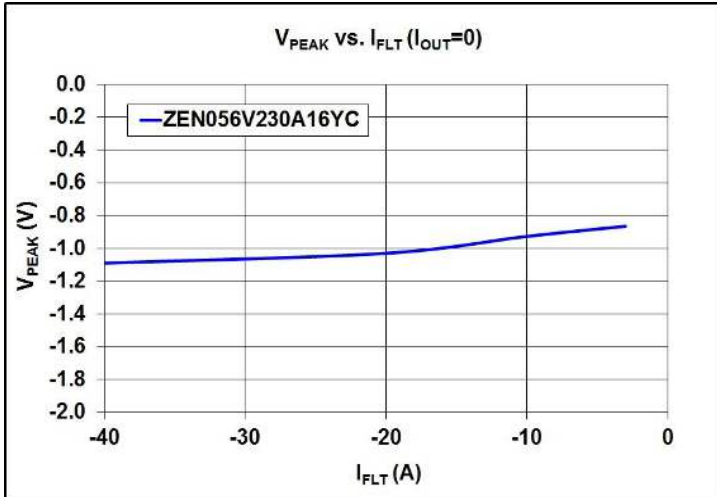

PACKAGING

Packaging	Tape & Reel	Standard Box
ZEN056V230A16YC	4000	20000

REEL DIMENSIONS (mm)

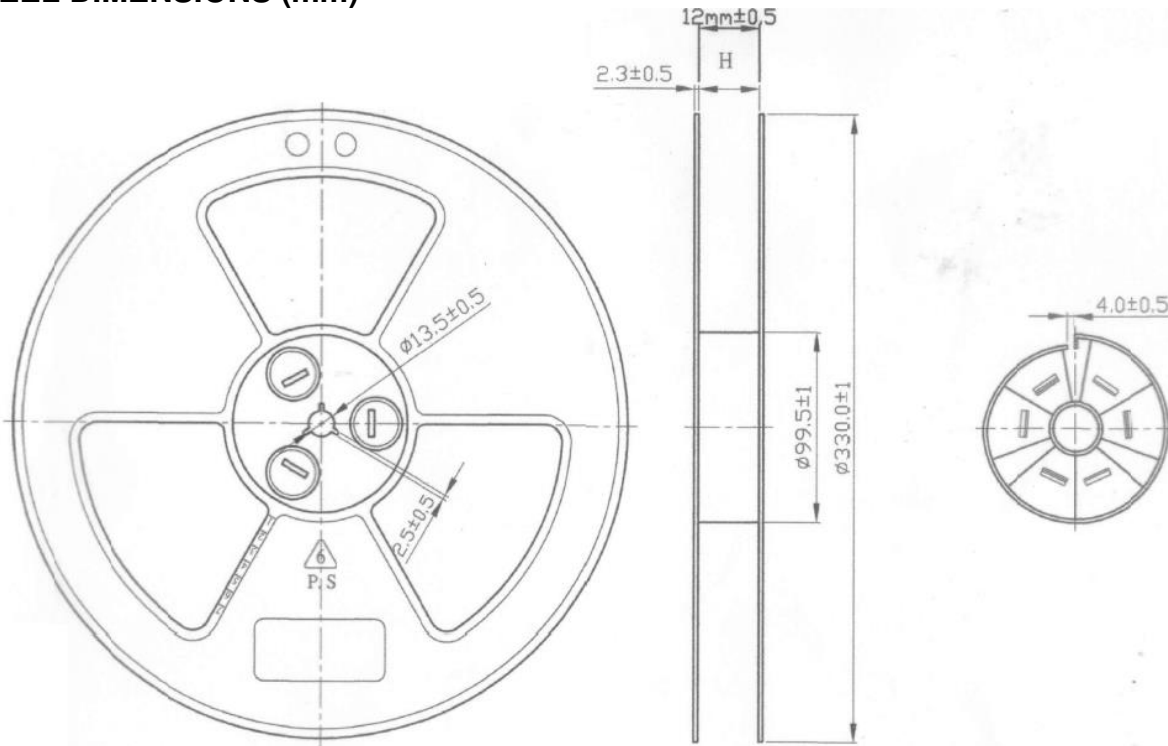

TAPE DIMENSIONS (mm)

Item	Dimension	tolerance
W	12.00	± 0.10
P	8.00	± 0.10
E	1.75	± 0.10
F	5.50	± 0.10
P2	2.00	± 0.10
D	1.50	$+0.10$ -0.00
D1	1.50	± 0.10
Po	4.00	± 0.10
10Po	40.00	± 0.20
Ao	4.20	± 0.10
Bo	5.25	± 0.10
Ko	1.40	± 0.10
t	0.24	± 0.05

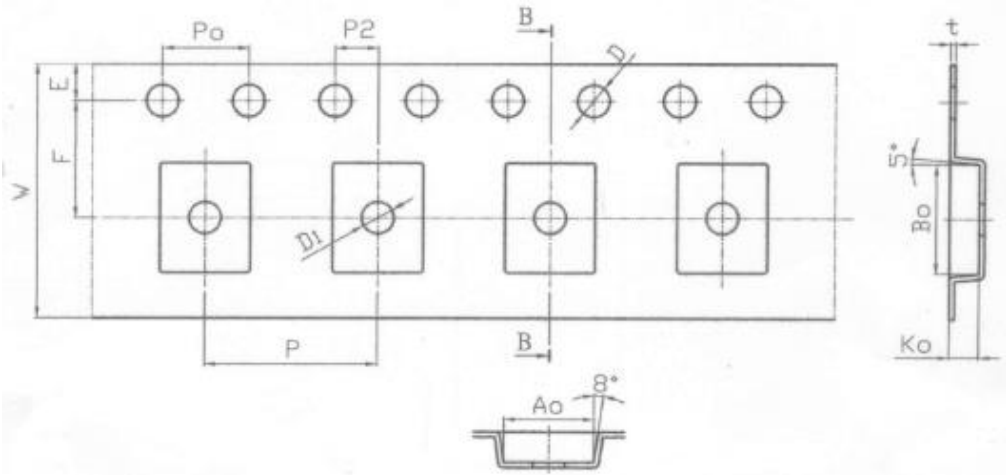

DEVICE MARKINGS INFORMATION

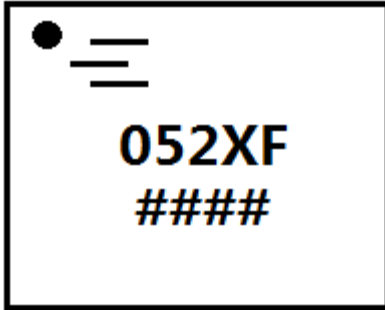

Markings	Vz	Hold current	Special code
052XF	5.6V	2.3A	F
####	Last 4 digits of batch number		

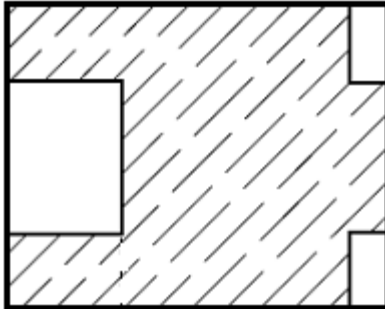

MATERIALS INFORMATION

ROHS Compliant

Directive 2002/95/EC
Compliant

ELV Compliant

Directive 2000/53/EC
Compliant

Pb-Free



Halogen Free*



* Halogen Free refers to: Br≤900ppm, Cl≤900ppm, Br+Cl≤1500ppm.

Littelfuse products are not designed for, and shall not be used for, any purpose (including, without limitation, automotive, military, aerospace, medical, life-saving, life-sustaining or nuclear facility applications, devices intended for surgical implant into the body, or any other application in which the failure or lack of desired operation of the product may result in personal injury, death, or property damage) other than those expressly set forth in applicable Littelfuse product documentation. Warranties granted by Littelfuse shall be deemed void for products used for any purpose not expressly set forth in applicable Littelfuse documentation. Littelfuse shall not be liable for any claims or damages arising out of products used in applications not expressly intended by Littelfuse as set forth in applicable Littelfuse documentation. The sale and use of Littelfuse products is subject to Littelfuse Terms and Conditions of Sale, unless otherwise agreed by Littelfuse.