



FTM84 / 85

Industrial Grade High Accuracy Thermal Air Velocity Transmitter



| Features |

- IP rating : IP67, rugged aluminum case, fit in variety harsh environment
- Capable of temperature compensation
- Linear calibration air velocity by computer, analog output or RS-485(Optional)
- High-speed, high-accuracy measurement, quickly respond
- Thermal mass flow sensor
- LCD, display air velocity and temperature
- Switch multifunction physical quantities : [m/s] 、 [ft/s] 、 [km/h] 、 [mph] 、 [kont]
- DIP SWITCH and RS-485 function
- Follow customer needs to plan measuring range, analog output, stations, and zero-point OFF SET or RS-485 adjustment zero-point OFF SET
- Free programmable software : Data logger / Maximum record 65535 data / Charts

| Applications |

- Monitor air velocity in supplying gas consumption dry process in industry process / Compressed air consumption measurement / Building / Factory / Clean room / Hospitals / Semiconductor / Electronics / Paper / Printing / Textiles / Steel and iron Industry / Food / Chemical / Pharmaceutical / Biotechnology industry

| Specification |

Input

Sensor type	Thermal mass flow sensor
Measuring range	1 m/s ; 2 m/s ; 5 m/s ; 10 m/s ; 20 m/s ; 40 m/s ; 60 m/s ; 90 m/s
Min. Measuring range	0.15 m/s
Temp. sensor & measuring range	Pt1000, 0 ... 80°C

Output

Output	0 ... 20 mA / 4 ... 20 mA / 0 ... 1 V / 0 ... 5 V / 0 ... 10 V
Default output	Out1 : Air velocity Out2 : Temp.(Default value : 0 ... 80°C)
Signal connection	3-wire
Load resistance	Current output : $\leq 500 \Omega$ Voltage output : $\geq 10 K\Omega$
Response time	$t_{90} \leq 3$ sec
Installation angle effect	<3% of the measured value (When the installation angle < 10°)
Display type	LCD module with green black light
Display range	Upon request, one decimal place, double line character (Up : Air velocity ; Down : Temp.)
Height of character	5.55mm

Accuracy(+25°C)

Air velocity	$\pm 1.5\%$ F.S.(Nonlinear error, hysteresis error, repeatability error)
Temperature(>2 m/s)	$\pm 0.3^\circ\text{C}$
Thermal sensitivity Temp. error	0.05% / °C

Environment

Measuring medium	Air
Operating Temp.	Housing : -20 ... +80°C Housing with display : -20 ... +60°C Probe : -20 ... +100°C
Operating humidity	95%RH(Non-condensing)
Storage Temp.	-20 ... +60°C
Proof pressure	10 bar

Electrical

Power supply	DC 8 ... 35 V & AC 12 ... 30 V
Current consumption	DC 8 V : 300 mA, 24 V : 100 mA AC 12 V : 350 mA, 24 V : 180 mA
Overvoltage protection	DC : <45 V ; AC : <40 V
Electrical connection	M12 metal connector / Terminal

Installation

Installation	Duct / Remote
Fix	1/2 PT outside thread

Protection

IP rating	IP67(Probe) ; IP65(Body)
Electric protection	■ Polarity protection ■ Over-voltage ■ Short circuit

Certification

Certification	CE
---------------	----

Material

Housing	Aluminum alloy
Probe	SUS
Filter	POM
Cable	PTFE(Remote FTM85)
Option	Metal mounting flange
Weight	FTM84 : 670 g / FTM85 : 782 g

*Please make sure the product and the device which connect with RS-485 are on common ground, avoid damaged product.

| Wind Tunnel Automatic QC System |



Air Velocity Automatic Calibration System

Wind Tunnel
Air Velocity Automatic Calibration System

【Wind Tunnel System Important advantage】

- Certified ILAC / TAF(ISO17025)
- Wind tunnel system(Detecting chamber) which could control the air velocity
- PC-based automatic air velocity controlling, QC inspection and HMI
- Automated output air velocity quality control inspection report, inspection report and factory inspection report
- Laboratory grade equipment to inspect the products produced, to confirm the best quality

| 3-Cycle Curve |

※According to IEC 61298 and ISO 17025 standard to measuring 3-cycle curve.
As the charts result, accuracy of test sample match with accuracy chart of standard source.

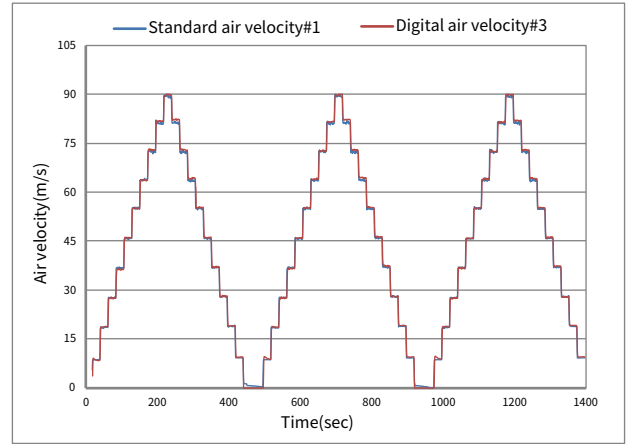
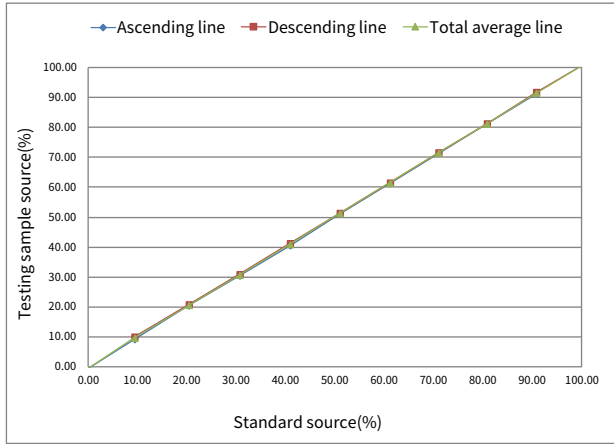

| Dimension |

M type

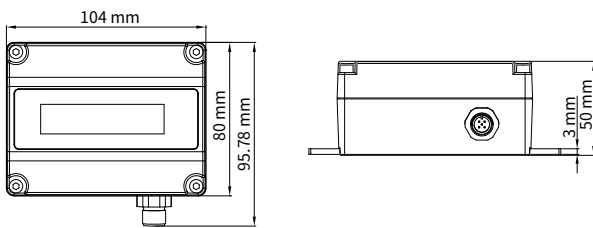

N type

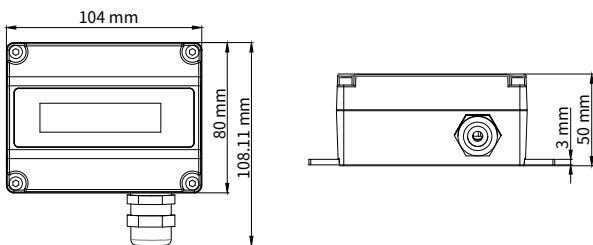

FTM84(Duct)

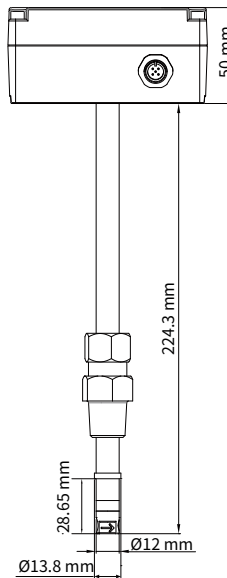

FTM85(Remote)

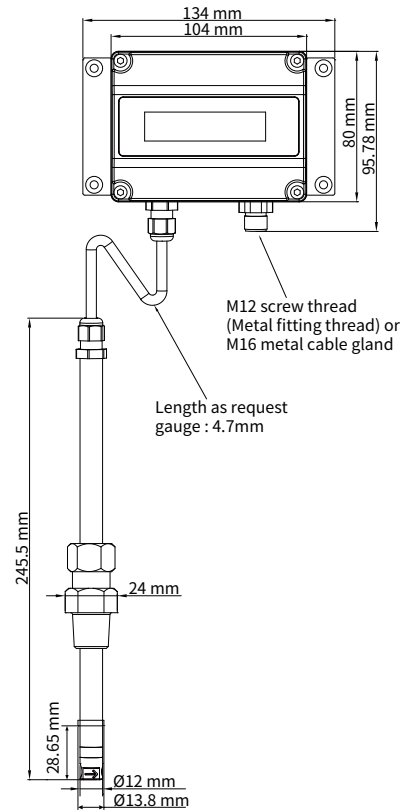

Electric Connector | Unit : mm

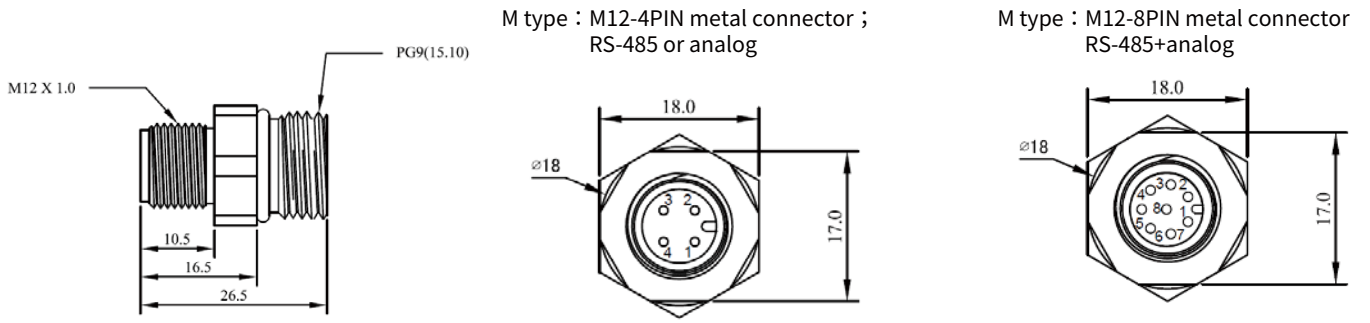

N type : M16 cable gland, RS-485+analog



Analog Diagram |



RS-485 Diagram |

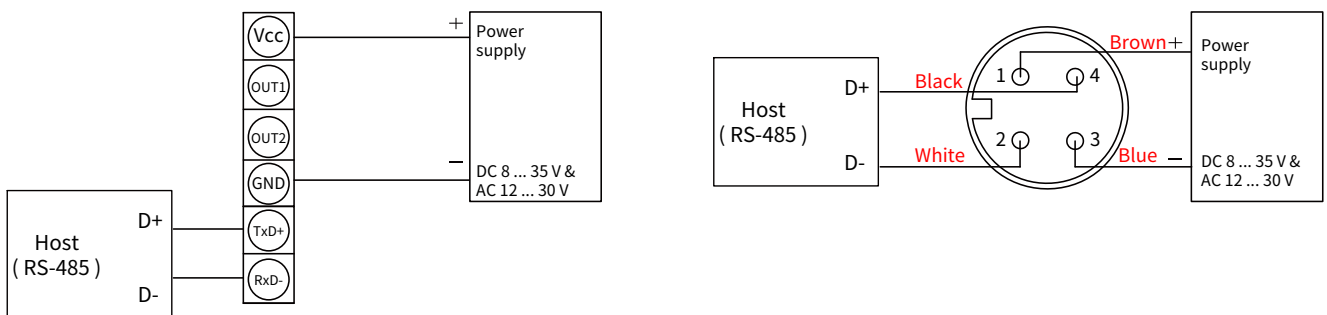

| Analog+RS-485 Diagram |

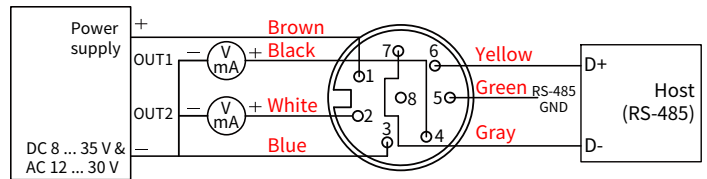
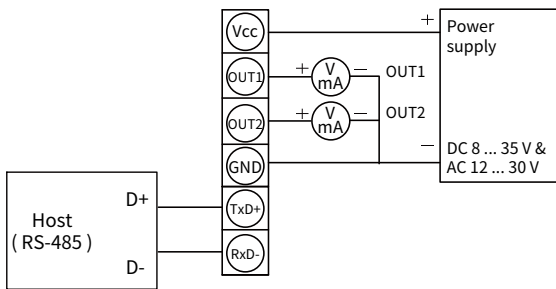

| DIP Switch |

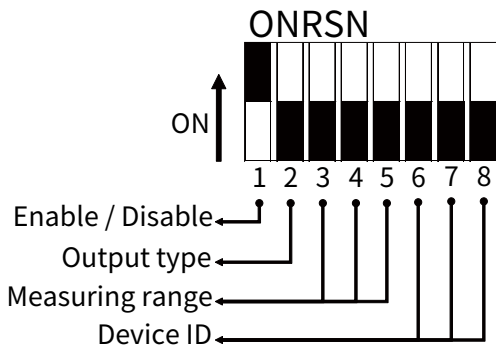

For FTM84 / 85 products, the setting status of DIP switch will be read by software while power on, and this reading action will not happen later on. Thus in order to read the DIP switch status again by software, the user must to reboot again if re-setting the DIP switch. The function of DIP Switch_2 to 8 only be effective while setting the DIP Switch_1 as "On" .

1. DIP switch active / deactivate : Set the DIP switch as On/ Off

STATUS	ON	OFF
DIP Switch 1	<input checked="" type="checkbox"/>	<input type="checkbox"/>

2. The type for analog output : Analog output type for Out1 & Out2

STATUS	0 ... 0 V	4 ... 20 mA
DIP Switch 2	<input type="checkbox"/>	<input checked="" type="checkbox"/>

3. Setting the output measuring range : Set the maximum value for analog output (The output physical type must be "Air Flow Velocity") ※Only switch wide to small range

DIP Switch 3	DIP Switch 4	DIP Switch 5	RANGE (m/s)
<input type="checkbox"/>	<input type="checkbox"/>	<input type="checkbox"/>	1
<input checked="" type="checkbox"/>	<input type="checkbox"/>	<input type="checkbox"/>	2
<input type="checkbox"/>	<input checked="" type="checkbox"/>	<input type="checkbox"/>	5
<input checked="" type="checkbox"/>	<input checked="" type="checkbox"/>	<input type="checkbox"/>	10
<input type="checkbox"/>	<input type="checkbox"/>	<input checked="" type="checkbox"/>	15
<input checked="" type="checkbox"/>	<input type="checkbox"/>	<input checked="" type="checkbox"/>	20
<input type="checkbox"/>	<input checked="" type="checkbox"/>	<input checked="" type="checkbox"/>	40
<input checked="" type="checkbox"/>	<input checked="" type="checkbox"/>	<input checked="" type="checkbox"/>	60

4. Setting the device ID : Set the slave device ID for modbus RTU.

DIP Switch 6	DIP Switch 7	DIP Switch 8	Device ID
<input type="checkbox"/>	<input type="checkbox"/>	<input type="checkbox"/>	1
<input checked="" type="checkbox"/>	<input type="checkbox"/>	<input type="checkbox"/>	2
<input type="checkbox"/>	<input checked="" type="checkbox"/>	<input type="checkbox"/>	3
<input checked="" type="checkbox"/>	<input checked="" type="checkbox"/>	<input type="checkbox"/>	4
<input type="checkbox"/>	<input type="checkbox"/>	<input checked="" type="checkbox"/>	5
<input checked="" type="checkbox"/>	<input type="checkbox"/>	<input checked="" type="checkbox"/>	6
<input type="checkbox"/>	<input checked="" type="checkbox"/>	<input checked="" type="checkbox"/>	7
<input checked="" type="checkbox"/>	<input checked="" type="checkbox"/>	<input checked="" type="checkbox"/>	8

| Ordering Guide |

	Installation	Range	Output	Power supply	Modbus	Cable	Electrical connector / Option
FTM	85	60	1	1	1	5	1
	84 : Duct 85 : Remote	01 : 1 m/s 02 : 2 m/s 05 : 5 m/s 10 : 10 m/s 20 : 20 m/s 40 : 40 m/s 60 : 60 m/s H90 : 90 m/s	1 : 4 ... 20 mA 2 : 0 ... 20 mA 6 : 0 ... 10 V 7 : 0 ... 5 V 8 : 0 ... 1 V 9 : RS-485	1 : DC 8 ... 35 V & AC 12 ... 30 V	0 : Analog 1 : RS-485 2 : RS-485&Analog ※M type : M12(8P) metal connector N type : M16 metal cable gland	2 : 2 m cable 5 : 5 m cable W : Other lengths	N : Metal cable gland M : M12 metal connector (with 2 m electrical cable) D : Display W : Other request

| Additional Option Test Report | For more detailed information please contact us.

■ ILAC / TAF

YUDEN-TECH CO.,LTD. Calibration Laboratory - (ILAC / TAF) Test report.
(TAF accreditation : 3032, complying with ISO / IEC 17025) TAF has mutual recognition arrangement with ILAC MRA

Project	Measurand level or range
Air velocity transmitter	0.2 m/s ... 60 m/s

■ ISO 9001

Project	Measurand level or range
Air velocity / Air volume	Air velocity : ≤ 120 m/s
	Air volume : 0.5 m ³ /h ... 1000 m ³ /h