

Description

The E-T-A Solid State Remote Power Controller (SSRPC) E-1048-S6xx is an opto decoupled transistorised switching device providing both protection and signalisation.

It may be used wherever safe switching and protection of resistive, inductive or lamp loads in DC voltage systems is required.

Typical applications

Automation

- interface module providing inexpensive power amplification at PLC outputs
- optimum protection of individual loads by monitoring the load circuit

Protection and control of

- motors
- solenoids
- lamps

Features

- Optimum load protection. Available in current ratings of 0.5 A; 1 A; 2 A; 4 A. No derating required over entire temperature range!
- Fast short-circuit limitation and disconnection
- Time/current dependent overload disconnection (simulating thermal-magnetic CBE trip curve)
- Remote control
- Fault indication: LED and signal output for overload/short-circuit signalisation, and wire break indication in the OFF condition (version -600) and in the OFF and ON condition (version -602)
- Physically isolated fault indication.
- Compact plug-in type

Ordering information

Type No.	
E-1048	Solid State Remote Power Controller
	Version
	S600 wire break indication in OFF condition (standard)
	S602 with permanent wire break monitoring
	Voltage rating
	DC 24 V DC 24 V (standard)
	Current ratings
	0.5 A
	1.0 A
	2.0 A
	4.0 A
E-1048 - S600 DC24 V 1.0 A	ordering example

Where remote control, wire break and LED indication is not required, please contact us for a thermal-magnetic circuit breaker (e.g. types 2210, 3600, 3900).



E-1048-S602

Technical data (T_{ambient} = 25 °C; at U_N)

Load circuit

Voltage rating U _S	DC 24 V (18...36 V)
Current rating I _N	0.5 A; 1 A; 2 A; 4 A (other ratings to special order)
Closed-circuit current I _{Contr}	typically 0.3 mA
Min. load current	
Standard version:	I _{load} > 1 mA
wire break indication in OFF condition	
Option: wire break indication in OFF and ON condition	
wire break ind. in OFF cond.	R _{load} > typ. 500 kΩ
wire break ind. in ON cond.	I _{load} < typ. 130 mA (0.5/1 A unit)
	I _{load} < typ. 500 mA (2/4 A unit)
Voltage drop U _{DSmax}	0.15 V; 0.3 V; 0.1 V; 0.2 V
Switch-on/switch-off time t _{on} /t _{off}	typ. 300 μs/700 μs with resistive load
Overload disconnection	approx. 1.5 (±0.3) × I _N after approx. max. 25 A (with 0.5 A and 1 A current ratings)
100 ms Short-circuit current (self-limiting)	max. 75 A (with 2 A and 4 A current ratings)
Short-circuit disconnection	< 250 μs

Control circuit

Voltage rating	DC 24 V
Voltage controlled input U _E	DC 0 V < low level < 5 V DC 8.5 V < high level < 36 V
Input current I _E	1...10 mA (8.5...36 V)
Max. switching frequency f _{max}	500 Hz
Reset time after short-circuit/overload disconnection	1 ms

Fault indication output F (opto coupler)

Voltage rating range	DC 5...36 V
Voltage rating range	DC 5...36 V
Max. load current	100 mA (ΔU < 2 V), with reverse polarity protection
Error indication	output F+ / F- conductive - wire break in load circuit - after short-circuit/overload disconnection
Parallel connection possible, as leakage current < 10 μA	

General data

Temperature range	0 °C...+60 °C
Insulation voltage (IEC 60664/VDE 0110)	2.5 kV _{rms}
Vibration	3 g, test to EN 60068-2-6 test Fc
Mass	34 g

Technical description

At the appropriate input level ($>8.5\text{ V}$), the opto decoupled input in the SSRPC will switch on a power transistor to connect the load to the plus pole of the load circuit supply (U_S).

The transistor will switch off when

- the control voltage (U_E) is removed
- there is a short-circuit/overload in the load circuit.

Status indication is provided by two LEDs (red and green).

Thermal-magnetic style overload protection occurs at approx. 1.5 times rated current. See time/current characteristic curves.

The SSRPC is fitted with blade terminals DIN 46244-A6.3-0.8 and is suitable for plug-in mounting with various E-T-A sockets (see Accessories).

Control circuit

ON condition:

If a voltage higher than 8.5 V is applied to the input terminals (-IN, +IN), the control current (from the PLC) will flow through the opto coupler. The output transistor will be conductive, the green LED will be lighted.

OFF condition:

A control voltage lower than 5 V will switch the output transistor off.

Load circuit

The load circuit switches depending on the control signal ("0" or "1"). It is electronically monitored for faults. In the event of a short-circuit the circuit is disconnected after max. 250 μs whilst upon inadmissible overload it is disconnected according to the time/current curves shown.

Fault indication output

The fault indication circuit (F+, F-) is opto decoupled from the load and control circuit.

In the OFF condition, this circuit will provide wire break indication, with the transistor output being open.

In the ON condition, the circuit will provide short-circuit and overload monitoring and indication.

Visual fault indication by red LED.

Status indication

Status indication	Fault indication output (opto coupler)	LED	
		green	red
non-conductive, no duty			
conductive, normal duty			
overload or short circuit at the output (and with option wire break indication in ON condition)			
wire break, in the OFF position			

Connection diagram

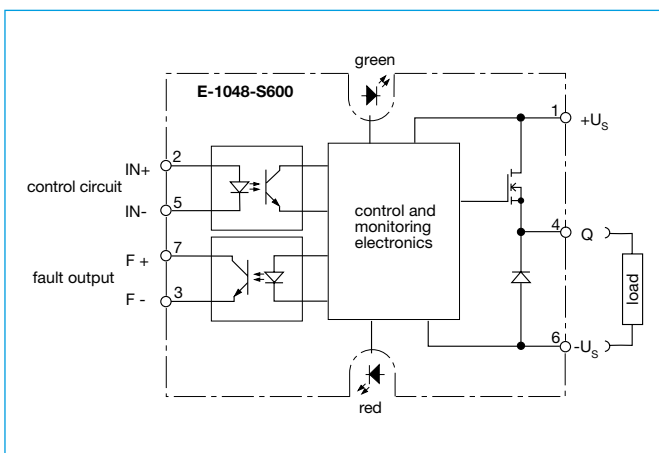

Dimensions

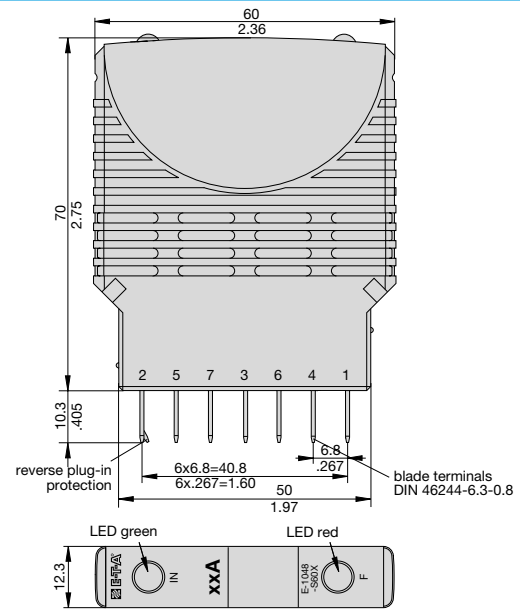

This is a metric design and millimeter dimensions take precedence ($\frac{\text{mm}}{\text{inch}}$)

Typical time/current characteristics ($T_A = 25\text{ }^\circ\text{C}$)

0.5 A and 1 A

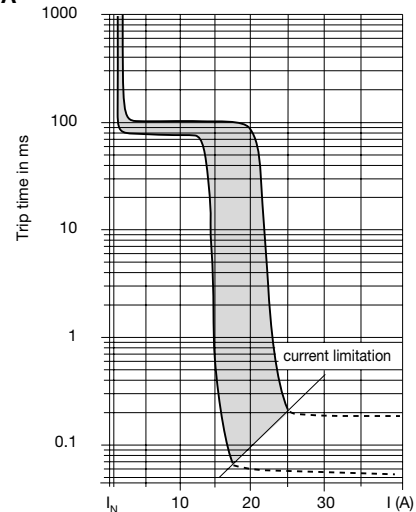

2 A and 4 A

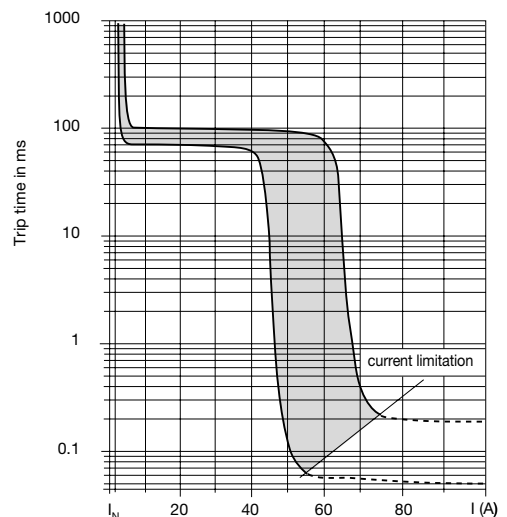

Functional diagrams E-1048-S6xx

Functional diagram E-1048-S6xx
wire break indication

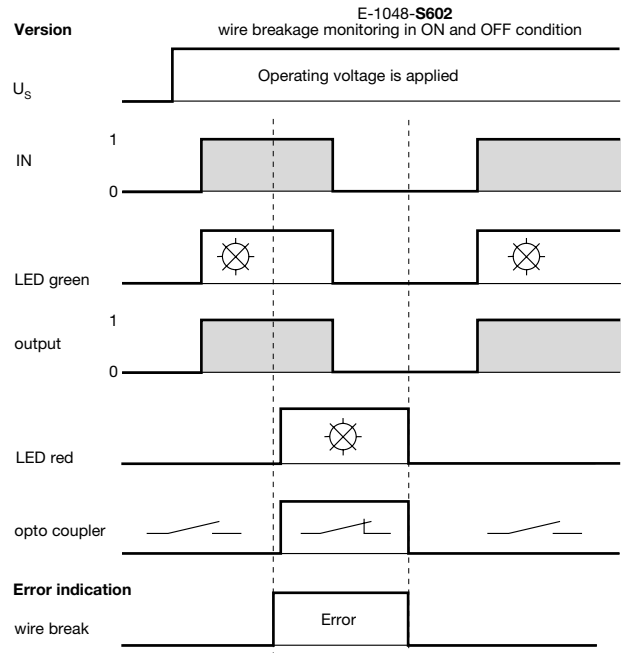
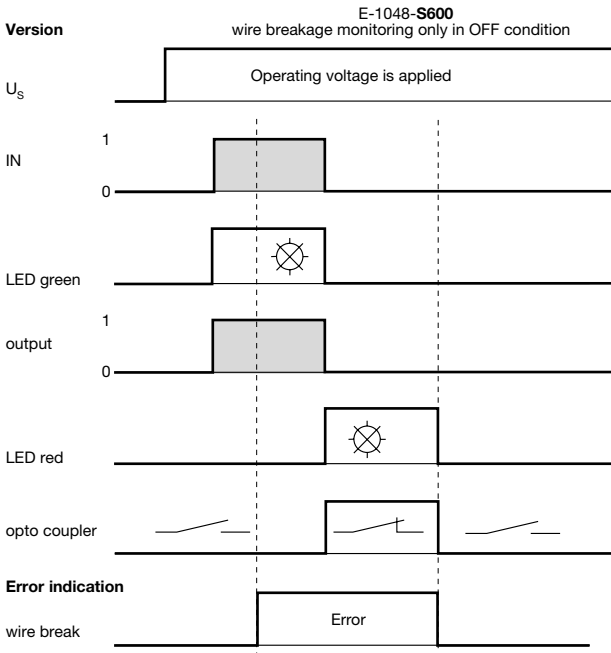

Functional diagram E-1048-S6xx
overload /short-circuit indication

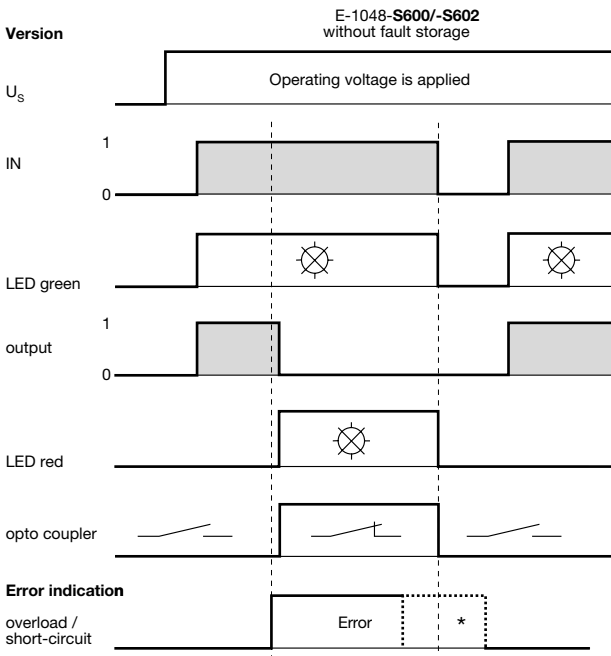

* Fault indication is reset when control voltage is switched off, whether the failure is still active or not.

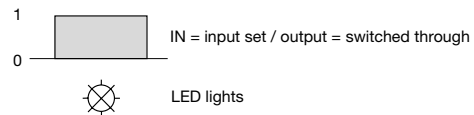

Accessories for E 1048-S6xx

Single mounting sockets

(up to 16 A max. load)
17-P10-Si
17-P70-Si
 (retaining clip Y 308 792 01)

(with adapter)

17-P10-Si-20025
17-P70-Si-20025

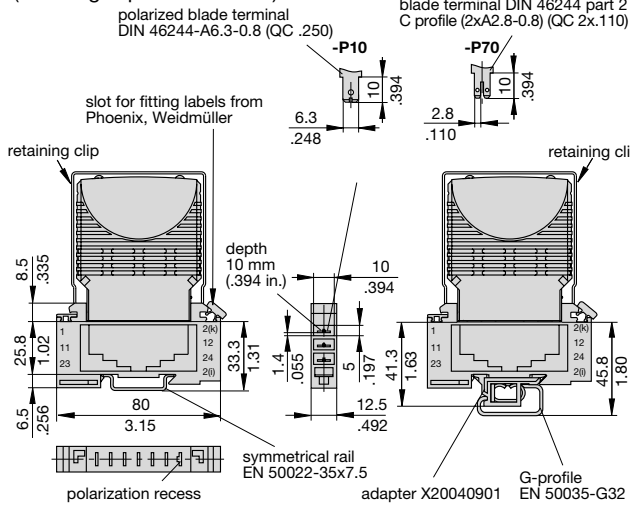

Busbar (10-way) (supplied as a complete package) for type 17 socket

(for max. 100 A continuous load, more positions available on request)
X 211 157 01 with terminal
X 211 157 02 without terminal

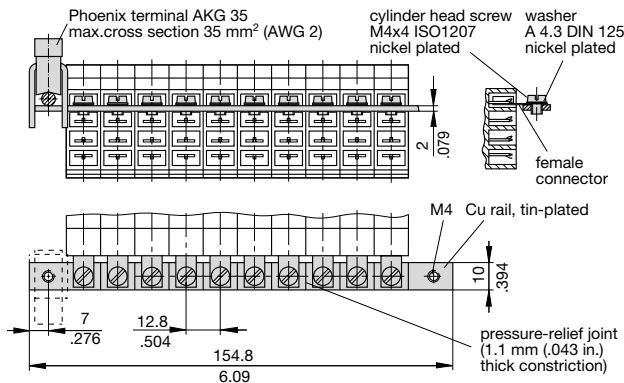

Insulating sleeving for busbar (10-way) Y 303 824 01

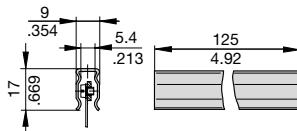

2-way mounting socket 23-P10-Si

6-way mounting socket 63-P10-Si

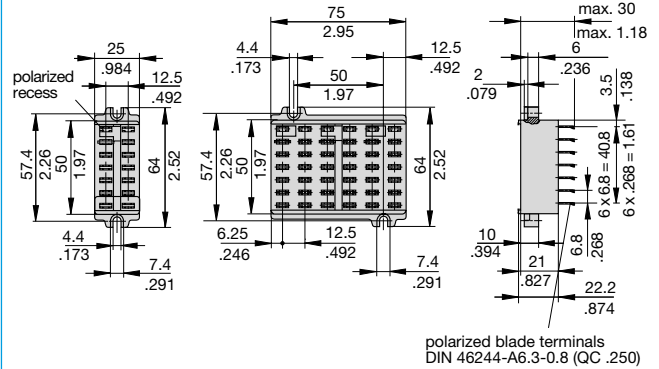

Connector bus links -P10

X 210 588 01 / 1.5 mm² (AWG 16), brown (up to 13 A max. load)
X 210 588 02 / 2.5 mm² (AWG 14), black (up to 20 A max. load)
X 210 588 03 / 2.5 mm² (AWG 14), red (up to 20 A max. load)
X 210 588 04 / 2.5 mm² (AWG 14), blau (up to 20 A max. load)

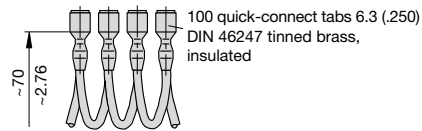

Retaining clip Y 308 792 01

recommended for a tight fit of types ESX10 / E-1048-S6xx / SB-S11-P1-xx with terminal blocks type 17 and 17plus

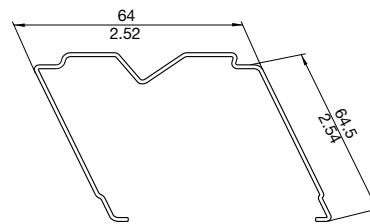

This is a metric design and millimeter dimensions take precedence ($\frac{\text{mm}}{\text{inch}}$)

Pin selection 17-P10-Si fitted with E-1048-S6xx

E-1048-S6xx	17-P10-Si	
IN + (2)	(2) [2(k)]	
IN - (5)	(5) [12]	
F + (7)	(7) [24]	
F - (3)	(3) [2(l)]	
-U _B (6)	(6) [23]	
Q (4)	(4) [11]	
+U _B (1)	(1) [1]	

All dimensions without tolerances are for reference only. In the interest of improved design, performance and cost effectiveness the right to make changes in these specifications without notice is reserved. Product markings may not be exactly as the ordering codes. Errors and omissions excepted.