

REVISIONS					
P	LTR	DESCRIPTION	DATE	DMN	APVD
E		REV PER ECO 19-019228	4-16-20	CT	DM

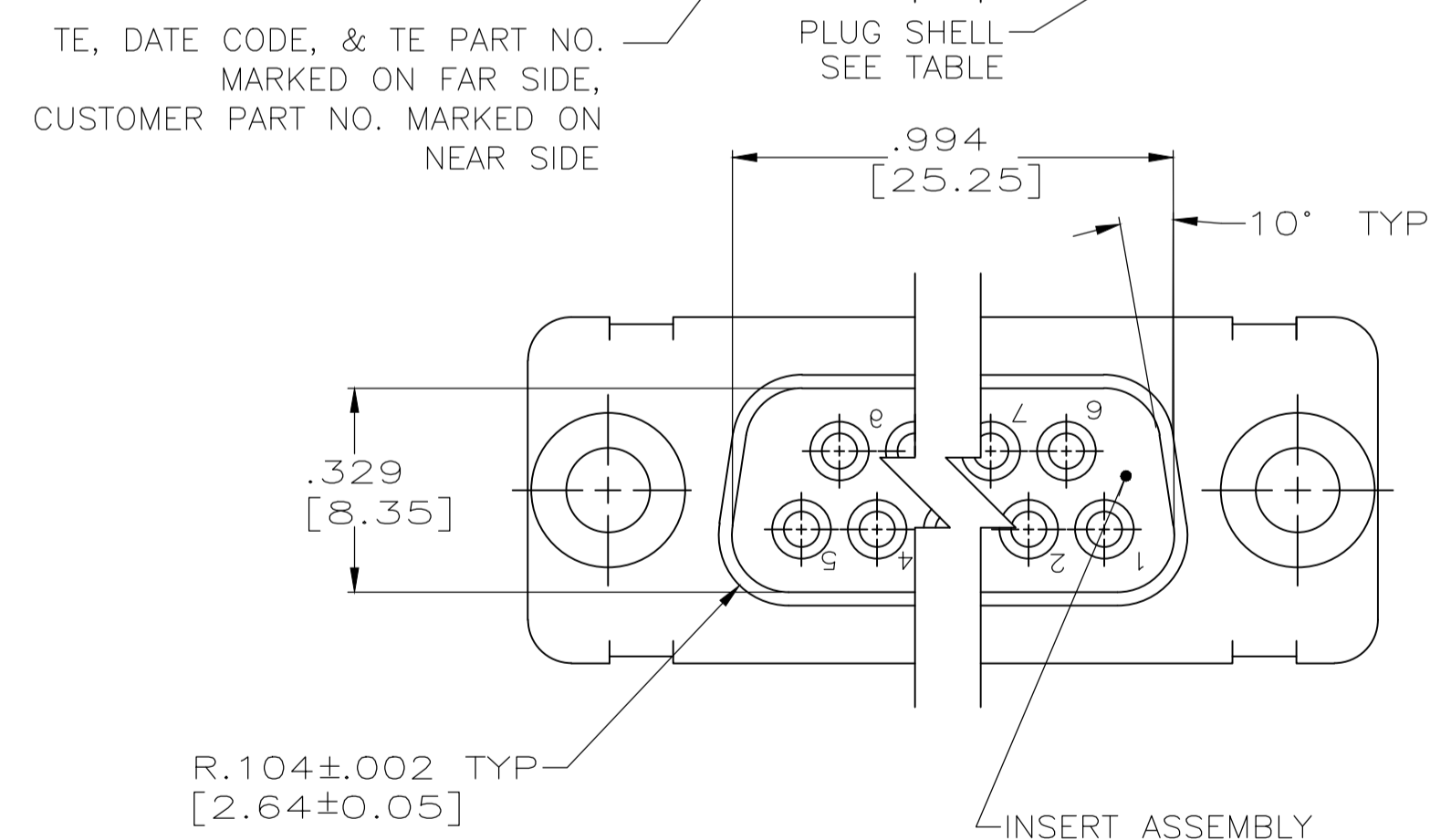

INSERT ASSEMBLY  
 MATL: POLYESTER PER MIL-M-24519  
 TYPE GPT-30F  
 COLOR: BLUE  
 OR DIALLYL PHTHALATE IN ACCORDANCE WITH MIL-M-14  
 TYPE SPG-F  
 COLOR: BLUE

1. CONTACTS INCLUDED IN ASSEMBLY.
- ⚠ CONTACT  
 BODY MATL: BERYLLIUM COPPER PER ASTM-B-197.  
 BODY FINISH: PLATED GOLD, .000050 MIN THK PER MIL-G-45204 OVER NICKEL, .000050 MIN THK PER QQ-N-290.  
 HOOD MATL: STAINLESS STEEL PER ASTM-A-167.  
 HOOD FINISH: PASSIVATED PER ASTM-A-380
  - ⚠ MATL: BRASS PER ASTM-B-36.
  - ⚠ FINISH: PLATED GOLD, .000050 MIN THK PER MIL-G-45204 OVER COPPER, .000100 MIN THK PER MIL-C-14550.

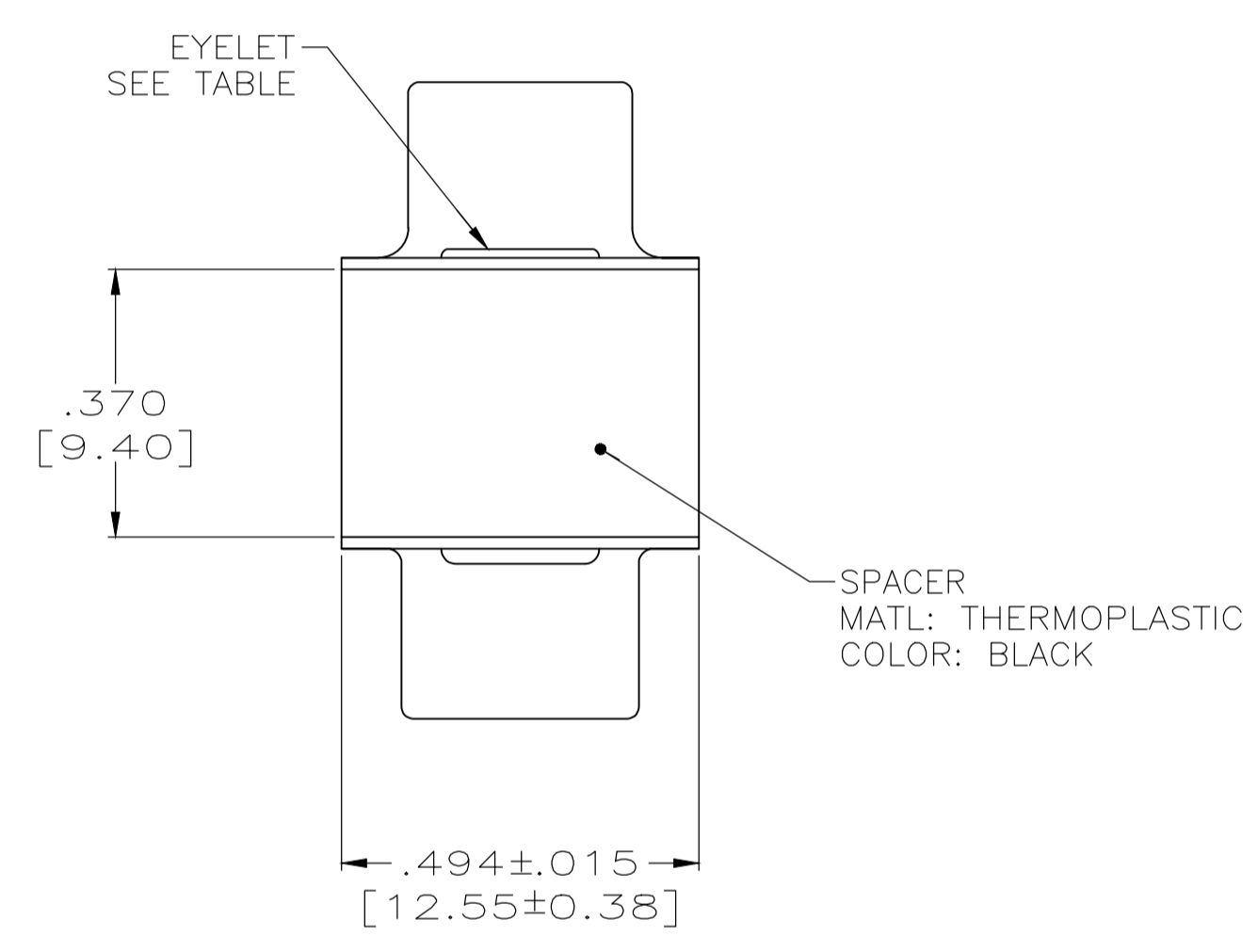
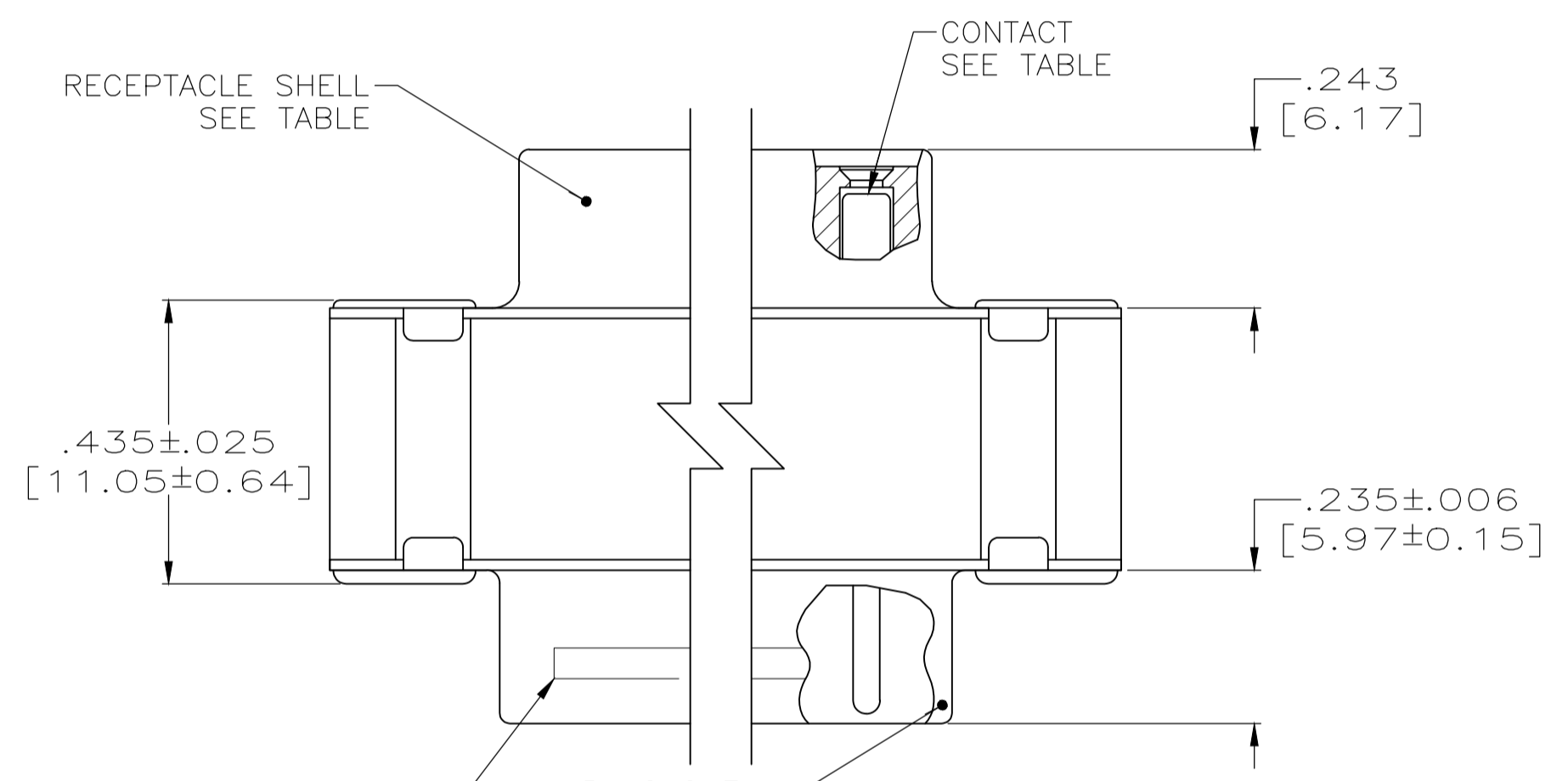
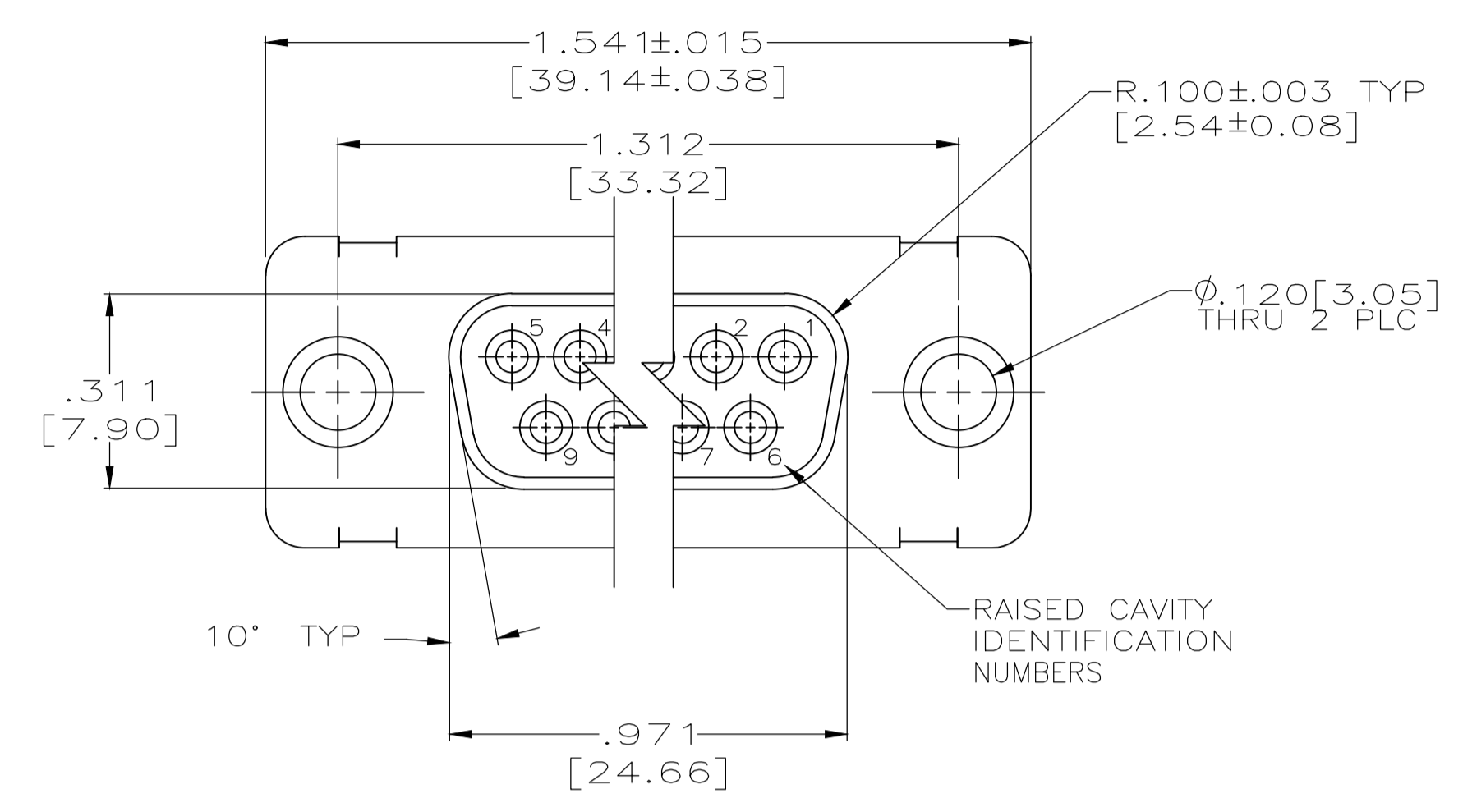
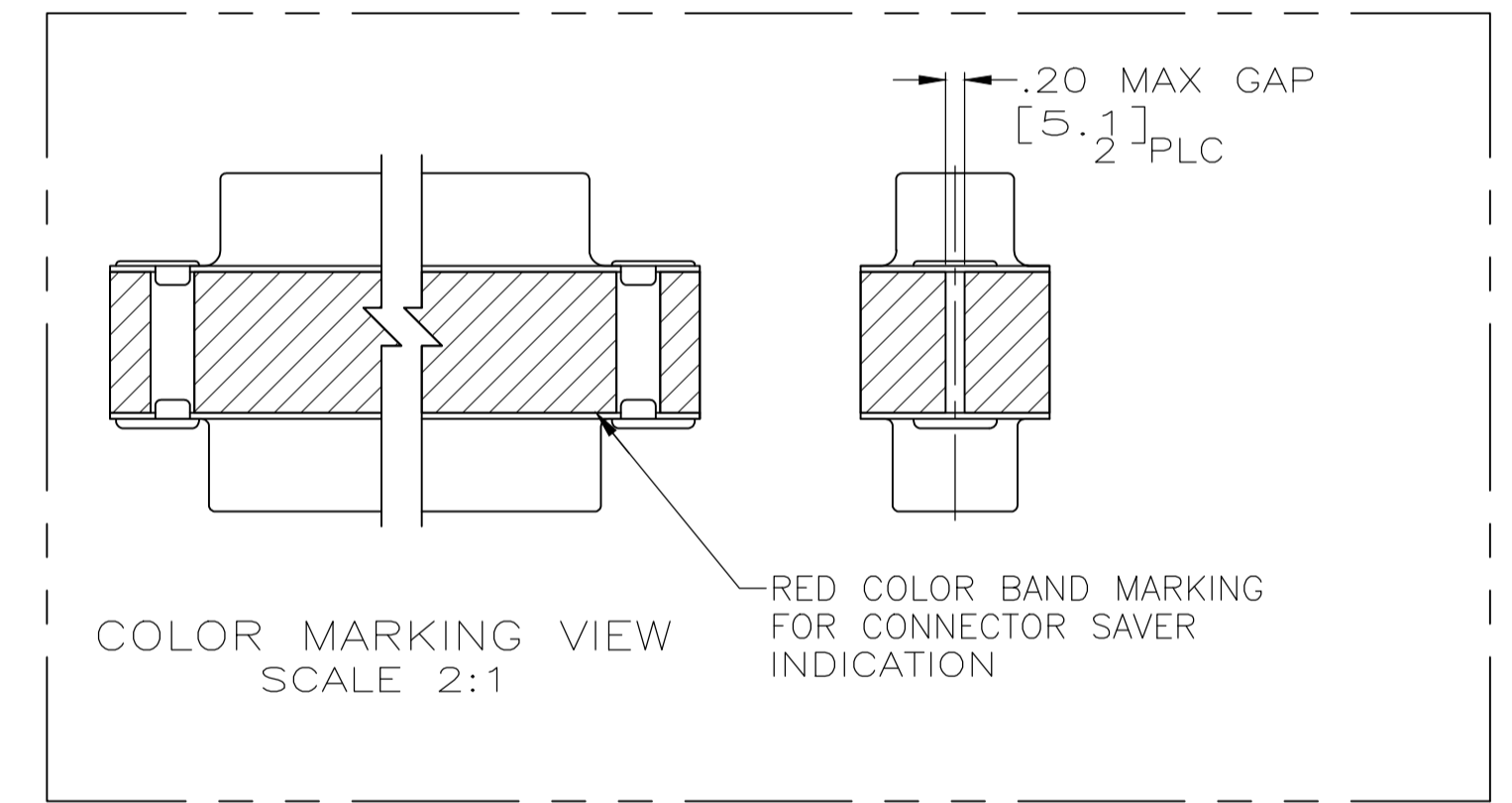

⚠ ⚠	⚠ ⚠	⚠	4U884 SOCN R10002677-0002	1218304-2
⚠ ⚠	⚠ ⚠	⚠	(1J02-002)	1218304-1
EYELET	SHELLS	CONTACT	CUSTOMER P/N	PART NO.
THIS DRAWING IS A CONTROLLED DOCUMENT.		DIN T. THOMPSON 19AUG98	TE Connectivity AMPLIMITE CONNECTOR SAVER SERIES 109, SIZE 2, 15 POS NON-REMOVABLE CONTACTS	
DIMENSIONS: INCHES		TOLERANCES UNLESS OTHERWISE SPECIFIED:		
		0 PLC ± - 1 PLC ± - 2 PLC ± - 3 PLC ± - 4 PLC ± - ANGLES ± -	APVD J. NORTON 19AUG98 PRODUCT SPEC APPLICATION SPEC SIZE A1 CAGE CODE 00779 DRAWING NO. 1218304 RESTRICTED TO	
MATERIAL		FINISH	WEIGHT 0.000000	SCALE 4:1 SHEET 1 OF 1 REV E
CUSTOMER DRAWING				