

GM5ZV96270A

Light Emitting Diode



■ Features

1. High brightness (600 mcd @ $I_F = 20$ mA)
2. Amber color, from AlGaInP/GaP LED chip

■ Agency Approvals/Compliance

1. RoHS compliant

■ Applications

1. General indication
2. Office automation/computers
3. Measuring equipment
4. Audio visual equipment
5. Home appliances
6. Telecommunications equipment
7. Tooling machines/Factory automation

Notice The content of data sheet is subject to change without prior notice.
In the absence of confirmation by device specification sheets, SHARP takes no responsibility for any defects that may occur in equipment using any SHARP devices shown in catalogs, data books, etc. Contact SHARP in order to obtain the latest device specification sheets before using any SHARP device.

External Dimensions

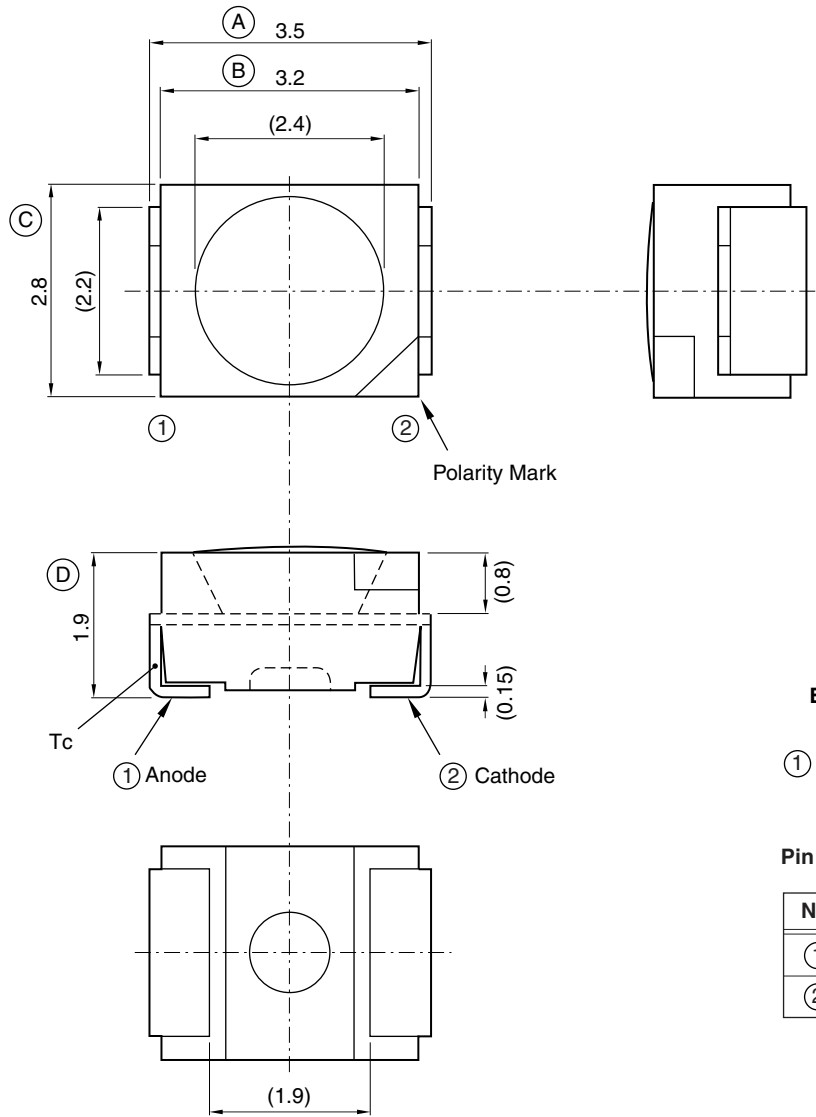

Equivalent Circuit

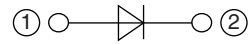

Pin Arrangement

No.	Name
①	Anode
②	Cathode

NOTES:

1. Units: mm
2. Unspecified tolerance: ± 0.3 mm
3. (): Reference dimensions
4. Case temperature (Tc) measurement point

■ Absolute Maximum Ratings

(Tc = 25°C)

Parameter	Symbol	Rating	Unit
Power dissipation	P	78	mW
Forward current	I _F	30	mA
Peak pulsed forward current *1	I _{FM}	100	mA
Forward current derating factor	DC	0.6	mA/°C
	Pulse	2.0	mA/°C
Reverse voltage	V _R	5	V
Operating temperature *2	Tc	-40 to +100	°C
Storage temperature	Tstg	-40 to +100	°C
Soldering temperature *3	Tsol	295	°C

*1 Duty ratio = 1/10, Pulse width = 0.1 ms

*2 Case temperature (See Outline Dimensions on page 2)

*3 Each terminal must be soldered with a 30 W soldering iron within 3 seconds under 295°C. For Reflow Soldering information, see Fig. 13.

*4 Operating current values here follow the derating curves shown in Fig. 1 through Fig. 3.

*5 This device uses the leads for heat sinking, therefore the Operating Temperature range is prescribed by Tc.

■ Electro-optical Characteristics

(Tc = 25°C)

Parameter	Symbol	Conditions	MIN.	TYP.	MAX.	Unit
Forward voltage	V _F	I _F = 20 mA	–	2.2	2.6	V
Luminous intensity *1	I _V		*3	600	*3	mcd
Dominant wavelength *2	λ _d		*4	588	*4	nm
Reverse current	I _R	V _R = 5 V	–	–	20	μA

*1 Measured by EG&G Model 550 (Radiometer/Photometer) after 20 ms drive (Tolerance: ±15%)

*2 Measured by Ohtsuka Electronics Model MCPD-2000 after 20 ms drive (Tolerance: x, y: ±0.02)

*3 See Luminous Rank table on page 8.

*4 See Dominant Wavelength Rank table on page 8.

Derating Curves

Fig. 1 Forward Current vs. Case Temperature

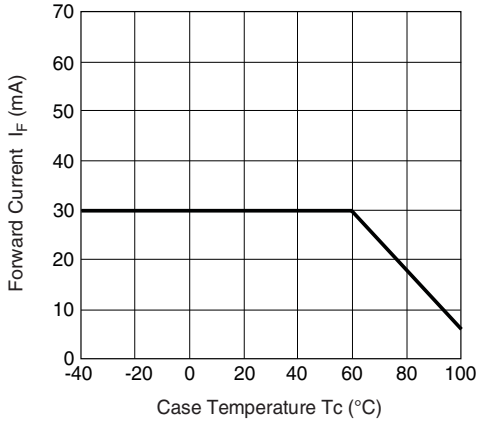

Fig. 2 Peak Forward Current vs. Duty Ratio

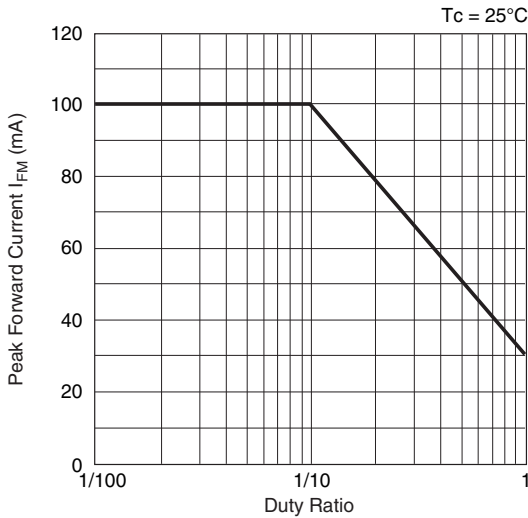
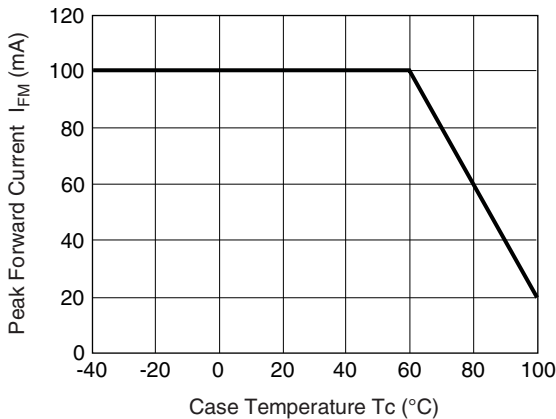

Fig. 3 Peak Forward Current vs. Case Temperature



Characteristic Diagrams (TYP.*)

*Characteristics data are typical data and are not guaranteed data.

Fig. 4 Relative Luminous Intensity vs. Forward Current

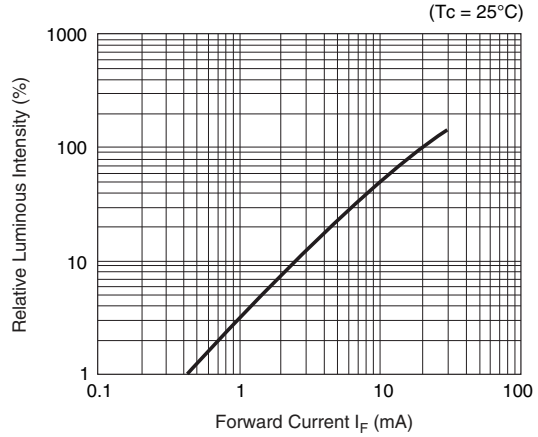

Fig. 5 Forward Current vs. Forward Voltage

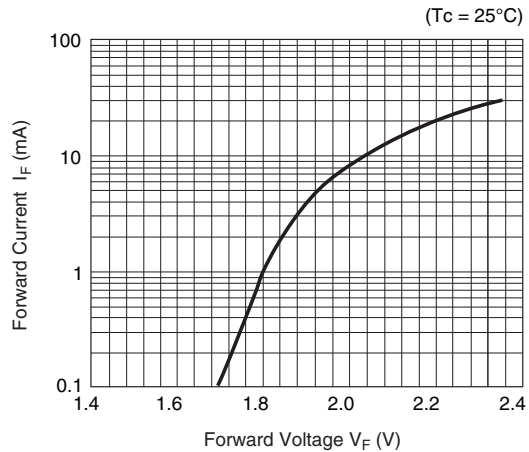
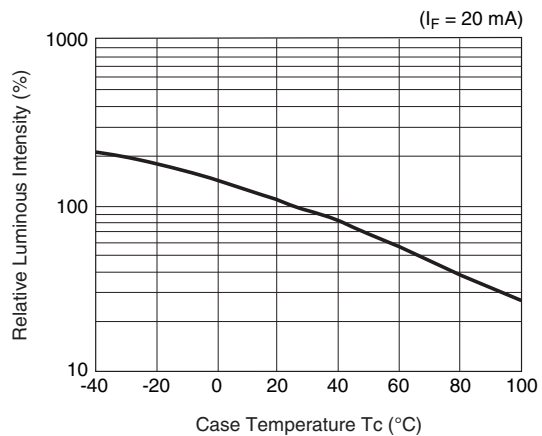
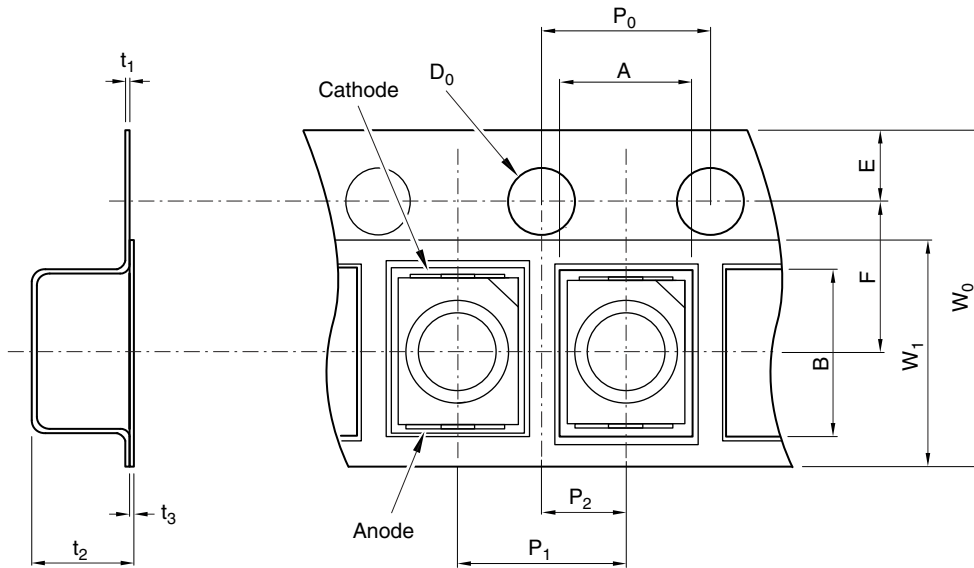

Fig. 6 Relative Luminous Intensity vs. Case Temperature



■ **Tape Specifications**

Fig. 7 Tape Shape and Dimensions



■ **Tape Dimension Specifications**

Parameter		Symbol	Dimension (mm)	Remarks
Concave square hole for parts insertion	Vertical	A	3.0	Dimension excludes corner R at the bottom inside
	Horizontal	B	3.7	
	Pitch	P ₁	4.0	
Round sprocket hole	Diameter	D ₀	1.5	
	Pitch	P ₀	4.0	Accumulated error ±0.5 mm/10 pitch
	Position	E	1.75	Distance between the edge of the tape and center of the hole
Center to center distance	Vertical	P ₂	2.0	Distance between center line of the concave square hole and round sprocket hole
	Horizontal	F	3.5	
Cover tape	Width	W ₁	5.4	
	Thickness	t ₃	0.1	
Carrier tape	Width	W ₀	8.0	
	Thickness	t ₁	0.3	
Thickness of entire unit		t ₂	2.6	With cover tape and carrier tape combined

■ Reel Specifications

Fig. 8 Reel Shape and Dimensions

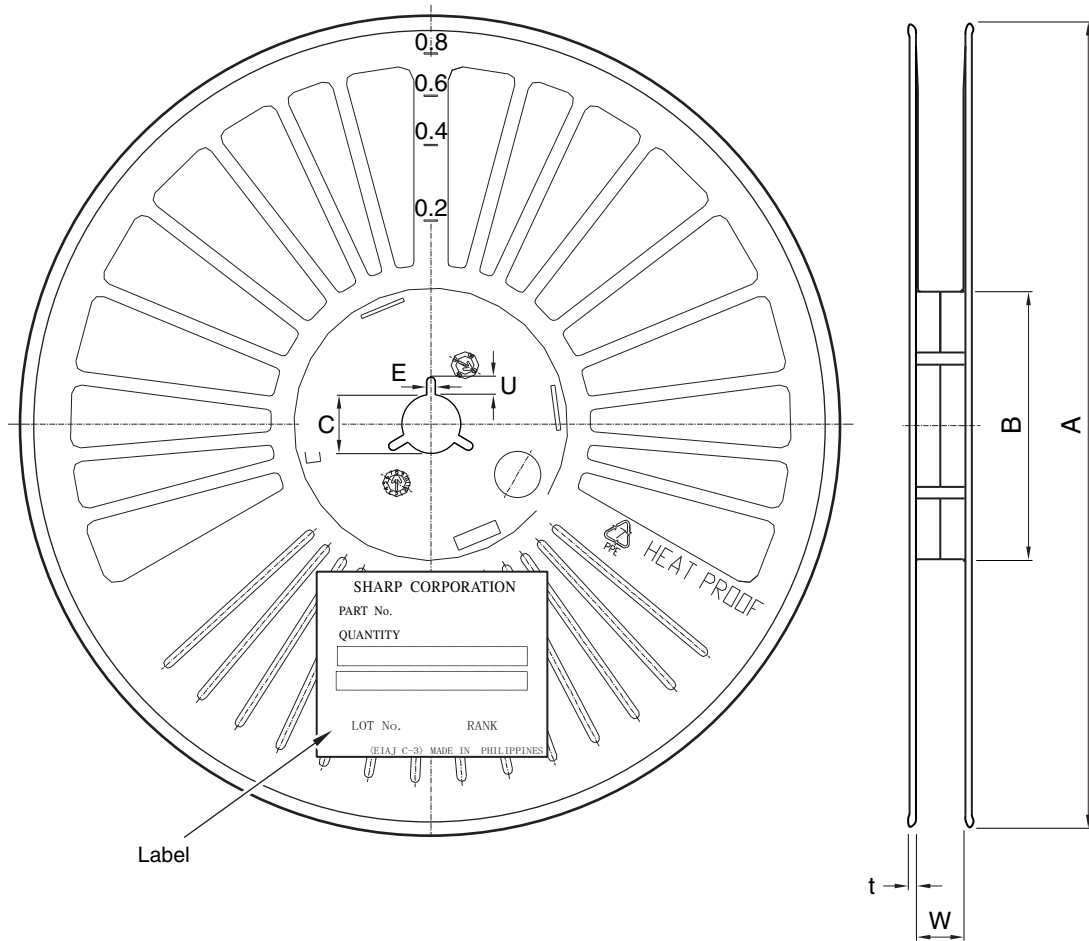

■ Reel Dimension Specifications

	Parameter	Symbol	Dimension (mm)	Remarks
Flange	Diameter	A	φ180	
	Thickness	t	1.3	
	Inner space direction	W	9.5	Dimension of shaft core
Hub	External diameter	B	φ60	
	Spindle hole diameter	C	φ13	
	Key slit width	E	2.0	
	Key slit depth	U	4	

*1 Label on side of flange: part name, quantity, lot number.

*2 Material: described on flange.

■ Taping Specifications

1. Leader tape standard: JIS C0806

Fig. 9 Leader Tape

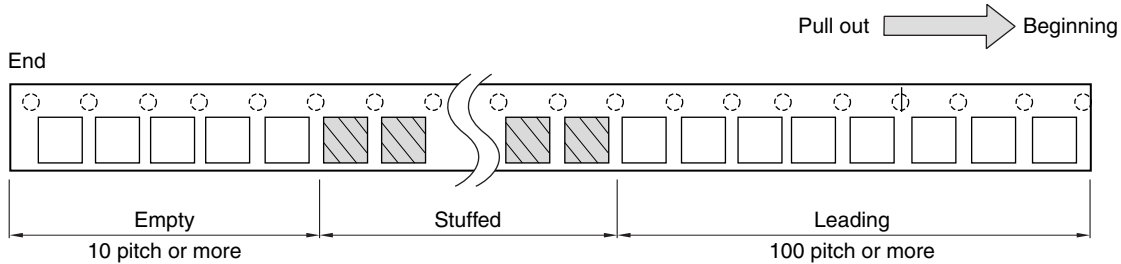

2. Cover tape peel resistance: $F = 0.1$ to 1.0 N ($\theta = 10^\circ$ or less). See Fig. 10.

Fig. 10 Tape Separation

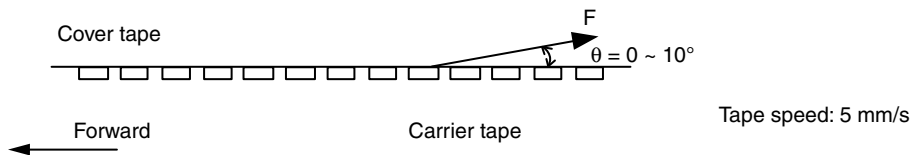

3. Tape bending resistance: Cover tape will remain in place on radii of 30 mm or more. Under 30 mm radii, the cover may separate.
4. Joints are not allowed in the cover tape.
5. Parts are packed with an average quantity of 2000 pieces per reel.
6. Product mass: 30 mg (approximately)
7. Sharp guarantees the following:
 - a. No contiguous empty spaces in the tape
 - b. Missing parts will not make up more than 0.1% of the total quantity.
 - c. Parts will be easily removed from the packing.
8. Parts will not stick to the cover tape as it is peeled.

Label and Marking Information

Fig. 11 Label Contents

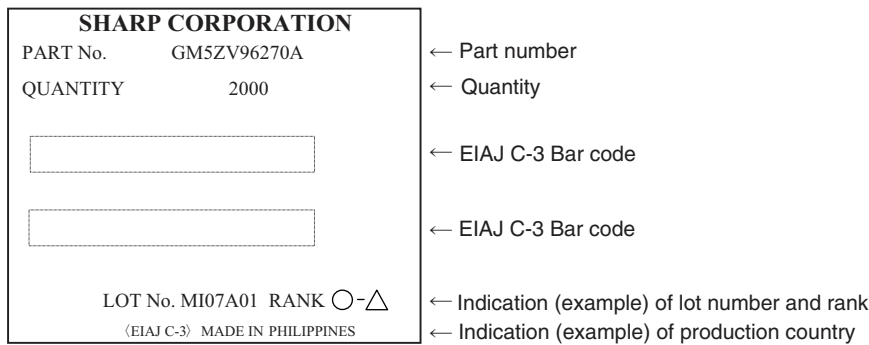

LOT Number

M I 07 A 01

① ② ③ ④ ⑤

- ① Production plant code (alphabetically)
- ② Production lot (single or double digits)
- ③ Production year (the last two digits of the year)
- ④ Production month
(to be indicated alphabetically with January corresponding to A)
- ⑤ Production date (01 ~ 31)

Rank ○ △ : ○ : Luminous intensity rank

△ : Dominant Wavelength rank

Luminous Intensity Rank Table (Tc = 25°C)

Rank	Luminous Intensity	Unit	Condition
K	383 ~ 746	mcd	I _F = 20 mA
L	552 ~ 1075		
M	795 ~ 1548		

*1 Parts are marked to the highest rank of their tested luminosity level. Tolerance: ±15%.

*2 Quantity of each rank is decided by Sharp.

Dominant Wavelength Rank Table (Tc = 25°C)

Rank	Luminous Intensity	Unit	Condition
a	580.5 ~ 585.0	nm	I _F = 20 mA
b	584.0 ~ 588.5		
c	587.5 ~ 592.0		
d	591.0 ~ 595.5		

*1 Ranks in this table are derived using a typical device, driven as noted here; and therefore are not guaranteed data. Tolerance: ±1.5nm.

*2 Quantity of each rank is decided by Sharp.

■ Design Notes

1. This product is not designed to resist electromagnetic and ionized-particle radiation. Moreover, it is not designed to directly resist excessive moisture, such as dew or condensation; or corrosive (salt) air or corrosive gases, such as Cl, H₂S, NH₃, SO₂, NO_x.
2. Do not allow the circuit design to apply any reverse voltage to the LEDs.
3. This part can be easily damaged by external stress. Make sure they are not mechanically stressed during or after assembly.
4. This part has a very high light output. Looking directly at it during full power output can cause injury.
5. Sharp recommends taking proper personal and environmental static control precautions when handling this part.
6. Materials of high thermal conductivity are incorporated in this device to allow generated heat to be effectively transferred from it to the circuit board. For best reliability, Sharp recommends against locating other sources of heat near the LED, and to design the circuit board in such a way that heat can easily escape from the circuit board. Sharp also recommends designing the circuit board so that the part's case temperature is always kept under 100°C (when the LED is turned on) including self-heating.
7. Sharp recommends handling these parts in a clean, non-dusty environment since surface dust may be difficult to remove and can affect the optical performance of the part.
8. Sharp recommends confirming the part's performance, reliability, and resistance to any of these conditions, if it is to be used in any of these environments:
 - Direct sunlight, outdoor exposure, dusty conditions
 - In water, oil, medical fluids, and organic solvents
 - Excessive moisture, such as dew or condensation
 - Corrosive (salt) air or corrosive gases, such as Cl, H₂S, NH₃, SO₂, NO_x

■ Manufacturing Guidelines

● Storage and Handling

1. Moisture-proofing: These parts are shipped in vacuum-sealed packaging to keep them dry and ready for use. See Fig. 12.

Fig. 12 Factory Moisture-proof Packaging

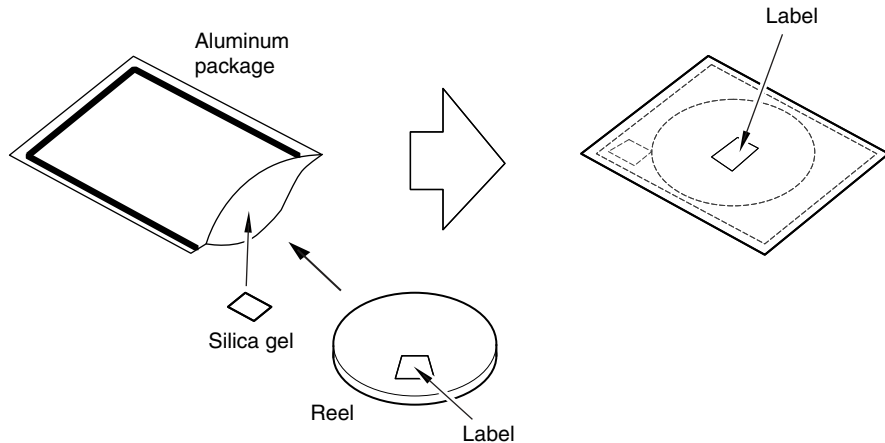

2. Store these parts between 5°C and 30°C, at a relative humidity of less than 60%.
3. After breaking the package seal, maintain the environment within 5°C to 30°C, at a relative humidity of less than 60%. Solder the parts within 3 days.
4. If the parts will not be used immediately, repack them in a dry box, or re-vacuum-seal them with a desiccant.
5. If the parts are exposed to air for more than 3 days, or if the silica gel telltale indicates moisture contamination, bake the parts:
 - When in the tape carrier, bake them at a temperature of 95°C to 100°C, for 16 to 24 hours.
 - When loose (in a metal tray) or on a PCB, bake them at a temperature of 110°C to 120°C, for 8 to 12 hours.
 - Note that the reels may become distorted if they are in a stack when baking. Confirm that the parts have cooled to room temperature after baking.

● Cleaning Instructions

1. Sharp does not recommend cleaning printed circuit boards containing this device. Process chemicals will affect the structural and optical characteristics of this device.
2. Sharp recommends the use of solder paste that does not require cleaning.
3. Avoid cleaning this part ultrasonically. If ultrasonic cleaning is unavoidable, verify the process before use, as the size of the bath, its duration, ultrasonic intensity, and PCB size and shape can affect the process. Recommended solvents are water or isopropyl alcohol.

● Soldering Instructions

1. When soldering with reflow methods, Sharp recommends following the soldering profile in Fig. 13.
2. Electrodes on this part are silver-plated. If the part is exposed to a corrosive environment, the plating may be damaged, thereby affecting solderability.
3. Do not subject the package to excessive mechanical force during soldering as it may cause deformation or defects in plated connections. Internal connections may be severed due to mechanical force placed on the package due to the PCB flexing during the soldering process.
4. Both PCB design and solder reflow machine specifications will affect the amount of heat conducted into this part during the production process.
5. When using backside dip methods, Sharp recommends giving careful consideration to the process, as board warping from heat may occur and the heat itself may be conducted into the package. Reflow after dip is recommended, but they can be performed in the opposite order; keep the interval between the two processes as short as possible.
6. When using a second reflow, the second process should be carried out as soon as possible after the first, unless there is a water-wash or solvent-wash process. Then the parts must be baked as specified in *Storage and Handling* before performing the second reflow.
7. The Reflow Profile shown in Fig. 13 should be considered as a set of maximum parameters. Since this part uses the leads for heatsinking, the peak temperature should be kept as cool as possible and the cooldown period lengthened as much as possible. Thermal conduction into the LED will be affected by the performance of the reflow process, so verification of the reflow process is recommended. These parts may be used in a nitrogen reflow process.
8. Sharp recommends verifying all processes before production begins.

Fig. 13 Temperature Profile

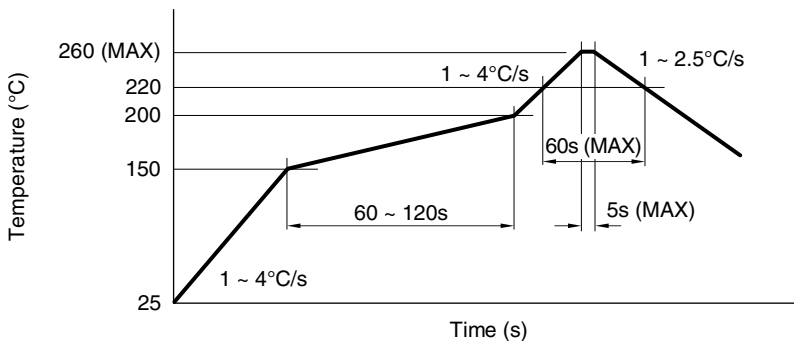

● Recommended Solder Pad Design

1. Solderability depends on reflow conditions, solder paste, and circuit board materials. Check the entire process before production commences.
2. Fig. 14 shows the recommended solder pattern for this part.
3. When using back side dip methods, Sharp recommends checking the process carefully: board warping from heat can cause mechanical failure in these parts, in addition to the high heat conducted into the part through the leads. Performing reflow after dip is recommended, with the interval between the two as short as possible.

Fig. 14 Recommended Solder Pad Design

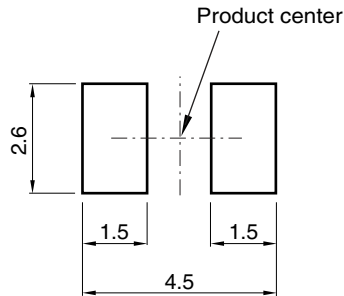

NOTE: Unit: mm

● Presence of ODCs

This product shall not contain the following materials, and they are not used in the production process for this product:

- Regulated substances: CFCs, Halon, Carbon tetrachloride, 1.1.1-Trichloroethane (Methylchloroform). Specific brominated flame retardants such as the PBBOs and PBBs are not used in this product at all.

This product shall not contain the following materials banned in the RoHS Directive (2002/95/EC).

- Lead, Mercury, Cadmium, Hexavalent chromium, Polybrominated biphenyls (PBB), Polybrominated diphenyl ethers (PBDE).

■ Important Notices

· The circuit application examples in this publication are provided to explain representative applications of SHARP devices and are not intended to guarantee any circuit design or license any intellectual property rights. SHARP takes no responsibility for any problems related to any intellectual property right of a third party resulting from the use of SHARP's devices.

· Contact SHARP in order to obtain the latest device specification sheets before using any SHARP device. SHARP reserves the right to make changes in the specifications, characteristics, data materials, structure, and other contents described herein at any time without notice in order to improve design or reliability. Manufacturing locations are also subject to change without notice.

· Observe the following points when using any devices in this publication. SHARP takes no responsibility for damage caused by improper use of the devices which does not meet the conditions and absolute maximum ratings to be used specified in the relevant specification sheet nor meet the following conditions:

(i) The devices in this publication are designed for use in general electronic equipment designs such as:

- Personal computers
- Office automation equipment
- Telecommunication equipment (terminal)
- Test and measurement equipment
- Industrial control
- Audio visual equipment
- Consumer electronics

(ii) Measures such as fail-safe function and redundant design should be taken to ensure reliability and safety when SHARP devices are used for or in connection with equipment that requires higher reliability such as:

- Transportation control and safety equipment (i.e., aircraft, trains, automobiles, etc.)
- Traffic signals
- Gas leakage sensor breakers
- Alarm equipment
- Various safety devices, etc.

(iii) SHARP devices shall not be used for or in connection with equipment that requires an extremely high level of reliability and safety such as:

- Space applications
- Telecommunication equipment (trunk lines)
- Nuclear power control equipment
- Medical and other life support equipment (e.g. scuba)

· If the SHARP devices listed in this publication fall within the scope of strategic products described in the Foreign Exchange and Foreign Trade Law of Japan, it is necessary to obtain approval to export such SHARP devices.

· This publication is the proprietary product of SHARP and is copyrighted, with all rights reserved. Under the copyright laws, no part of this publication may be reproduced or transmitted in any form or by any means, electronic or mechanical, for any purpose, in whole or in part, without the express written permission of SHARP. Express written permission is also required before any use of this publication may be made by a third party.

· Contact and consult with a SHARP representative if there are any questions about the contents of this publication.