

SureCross DX80 FlexPower Counter Node



more sensors, more solutions

Configurable Node with 2 selectable counter inputs, 2 selectable discrete inputs, and 2 NMOS discrete outputs



The SureCross® wireless system is a radio frequency network with integrated I/O that can operate in most environments and eliminate the need for wiring runs. Wireless networks are formed around a Gateway, which acts as the wireless network master device, and one or more Nodes.

- Wireless industrial I/O device with two selectable discrete inputs, two selectable discrete pulse counter inputs (rate or event; sinking, sourcing, or self-energized), and two NMOS discrete outputs
- User selectable 10 kHz event counter(s) and/or 25 kHz rate counter
- FlexPower® power options allows for +10 to 30V dc, solar, and battery power sources for low power applications.
- DIP switches for user configuration
- Frequency Hopping Spread Spectrum (FHSS) technology and Time Division Multiple Access (TDMA) control architecture ensure reliable data delivery within the unlicensed Industrial, Scientific, and Medical (ISM) band
- Transceivers provide bidirectional communication between the Gateway and Node, including fully acknowledged data transmission
- Lost RF links are detected and relevant outputs set to user-defined conditions
- The DX80...C models are certified for use in Class I, Division 2, Group A, B, C, D; Zone 2 (Category 3G) Hazardous Locations when properly installed in accordance with the National Electrical Code, the Canadian Electrical Code, or applicable local codes/regulations (see Specifications)

For additional information, updated documentation, and accessories, refer to Banner Engineering's website, www.bannerengineering.com/surecross.

Models	Frequency	Environmental Rating	I/O
DX80N9X2S4A2	900 MHz ISM Band	IP67, NEMA 6	Inputs: Two selectable discrete, two selectable counter Outputs: Two NMOS sinking discrete
DX80N2X2S4A2	2.4 GHz ISM Band		
DX80N9X2S4A2C	900 MHz ISM Band	IP20, NEMA 1 Class I, Division 2, Group A, B, C, D Hazardous Locations (see Specifications)	
DX80N2X2S4A2C	2.4 GHz ISM Band		

Internal antenna models are also available. For more information, contact your local Banner Engineering Corp. representative.



WARNING: Not To Be Used for Personnel Protection

Never use this device as a sensing device for personnel protection. Doing so could lead to serious injury or death. This device does not include the self-checking redundant circuitry necessary to allow its use in personnel safety applications. A sensor failure or malfunction can cause either an energized or de-energized sensor output condition.

SureCross User Configuration Tool



The User Configuration Tool (UCT) offers an easy way to link I/O points in your wireless network, view I/O register values graphically, and set system communication parameters when a host system is not part of the wireless network.

The UCT requires a special USB to RS-485 (model number BWA-UCT-900 for 1 Watt radios, BWA-HW-006 can be used for all other radios) converter cable to pass information between your computer and the Gateway. Download the most recent revisions of the UCT software from Banner Engineering's website: <http://www.bannerengineering.com/wireless>.



Setting Up Your Wireless Network

To set up and install your wireless network, follow these steps:

1. Configure the DIP switches of all devices.
2. Connect the sensors to the SureCross devices.
3. Apply power to all devices.
4. Form the wireless network by binding the Nodes to the Gateway. If the binding instructions are not included in the datasheet, refer to the product manual for binding instructions.
5. Observe the LED behavior to verify the devices are communicating with each other.
6. Conduct a site survey between the Gateway and Nodes. If the site survey instructions are not included in this datasheet, refer to the product manual for detailed site survey instructions.
7. Install your wireless sensor network components. If installation instructions are not included in this datasheet, refer to the product manual for detailed installation instructions.

For additional information, including installation and setup, weatherproofing, device menu maps, troubleshooting, and a list of accessories, refer to one of the following product manuals.

- SureCross Quick Start Guide: Banner part number [128185](#)
- SureCross Wireless I/O Network Manual: [132607](#)
- Web Configurator Manual (used with "Pro" and DX83 models): [134421](#)
- Host Configuration Manual [132114](#)

Configuring the DIP Switches

Before making any changes to the DIP switch positions, disconnect the power. DIP switch changes will not be recognized if power isn't cycled to the device.

For parameters not set via DIP switches, use the User Configuration Tool (UCT) to make configuration changes. For parameters set using the DIP switches, the DIP switch positions override any changes made using the User Configuration Tool.

DIP Switch Settings

Switches								
Device Settings	1	2			5	6	7	8
Rotary switch address mode	OFF*							
Extended address mode	ON							
Modbus or UCT configured (overrides switches 3-8)		OFF*						
DIP switch configured		ON						
Discrete IN #1 Sinking (NPN)					OFF*			
Discrete IN #1 Sourcing (PNP)					ON			
Discrete IN #2 Sinking (NPN)						OFF*		
Discrete IN #2 Sourcing (PNP)						ON		
Counter 2: rate (frequency) counter							OFF*	
Counter 2: event counter							ON	
Report Rate 16 seconds								OFF*
Report Rate 1 second								ON

* Default configuration

Address Mode

The SureCross wireless devices may use one of two types of addressing modes: rotary dial addressing or extended addressing. In **rotary dial** address mode, the left rotary dial establishes the network ID and the right rotary dial sets the device ID. The wireless network is restricted to a maximum of 16 devices.

Extended address mode uses a security code to "bind" Nodes to a specific Gateway. Bound Nodes can only send and receive information from the Gateway to which they are bound. In extended address mode, wireless networks may contain up to 48 radio devices. For more information on extended address mode, refer to the SureCross™ Wireless I/O Network product manual.

The device ships in rotary dial address mode by default, with the DIP switch in the OFF position. To use extended address mode, change the DIP switch to the ON position.

Counter Input Type

For the selectable counter input, select from the two types of counters: frequency (rate) or event. By default this selectable counter input is defined as a frequency (rate) counter.

The **frequency counter** calculates the frequency of the input signal, in Hz. The **event counter** counts the total number of times an input signal changes to the high/ON/1 state. The counter values are saved in EEPROM every hour. After power up, the saved value is restored as the beginning count. Setting the counter using the preset or clear functions saves the preset value or zeroes in EEPROM.

The counter increments on the falling edge of an input signal when the signal level crosses the threshold.

Discrete Input Type

Select the type of discrete input sensors to use with this device: sourcing (PNP) sensors or sinking (NPN) sensors.

Modbus/User Configuration Tool (UCT) or DIP Switch Configured

In Modbus/UCT Configured mode, the device parameters are changed using the User Configuration Tool (UCT) or a Modbus command. All DIP switch positions are ignored. In DIP Switch Configured mode, use the DIP switches to configure the parameters listed in the table.

Report Rate

The report rate defines how often the device reports inputs to the Gateway. For FlexPower™ applications, setting the report rate/interval to longer intervals extends the battery life.

DIP Switch Settings (Counter DIP Switches)

The counter input DIP switches define the characteristics of the counter inputs.

Device Settings	Counter Input 1 DIP Switches				Counter Input 2 DIP Switches			
	1	2	3	4	5	6	7	8
Low threshold (0.25V)	OFF*							
High threshold (1.5V)	ON							
Debounce enabled		OFF*						
Debounce disabled		ON						
Self-energized input (e.g. mag pickup)			OFF*	OFF*				
Enable PNP (sourcing)			OFF	ON				
Enable NPN (sinking)			ON	OFF				
Debounce enabled					OFF*			
Debounce disabled					ON			
Self-energized input (e.g. mag pickup)						OFF*	OFF*	
Enable PNP (sourcing)						OFF	ON	
Enable NPN (sinking)						ON	OFF	
Low threshold (0.25V)								OFF*
High threshold (1.5V)								ON

* Default configuration

Debounce establishes how to examine a signal's transitions. The factory default setting is to activate the input filtering to compensate for unclean state transitions. To turn off the input filtering, set the switch to the ON position.

Inputs. Counter switches 6 and 7 define the inputs as self-energized, sinking (NPN), or sourcing (PNP). A self-energized input does not require pull-up or pull-down devices for proper operation. A magnetic pick-up is a self-energized input. The input threshold can be adjusted to compensate for low amplitude signals.

Threshold. The counter has a selectable input threshold of 0.25V or 1.5V. For sinking (NPN) or sourcing (PNP) inputs, set the threshold to 1.5V.

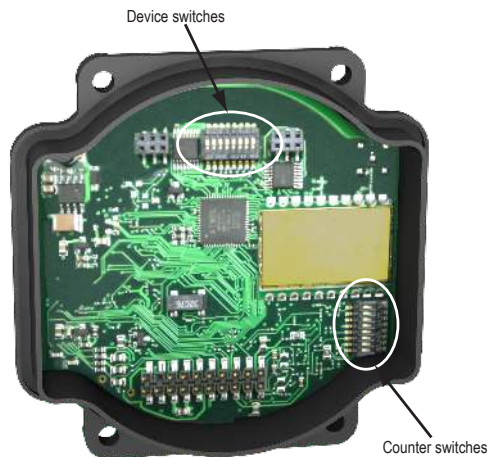

Wiring Your SureCross® Device

Use the following wiring diagrams to first wire the sensors and then apply power to the SureCross devices.

5-pin Euro-Style Wiring (Nodes)

Wiring the 5-pin Euro-style connector depends on the model and power requirements of the device. Connecting dc power to the communication pins will cause permanent damage. For FlexPower devices, do not apply more than 5.5V to the gray wire.

	Wire No.	Wire Color	10 to 30V dc Powered Nodes	Battery Powered Nodes
	1	Brown	10 to 30V dc	
	2	White		
	3	Blue	dc common (GND)	dc common (GND)
	4	Black		
	5	Gray		3.6 to 5.5V dc

DX80...C Wiring

Wiring power to the DX80...C models varies depending on the power requirements of the model. Connecting dc power to the communication pins (Tx/Rx) will cause permanent damage. For FlexPower devices, do not apply more than 5.5V to the gray wire.

Terminal Label	Gateway, DX85	10 to 30V dc Powered Nodes	Battery Powered Nodes
V+	10 to 30V dc	10 to 30V dc	
Tx/+	RS485 / D1 / B / +		
V-	dc common (GND)	dc common (GND)	dc common (GND)
Rx/-	RS485 / D0 / A / -		
B+			3.6 to 5.5V dc

Terminal Block (IP67 Housing)

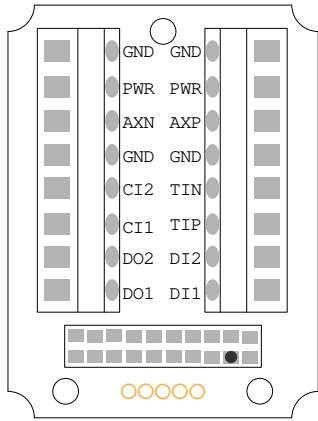

- AXN, AXP. Not used. Do not make any wiring connections to these terminals.
- CIx. Counter IN x.
- DIx. Discrete IN x.
- DOx. Discrete OUT x.
- GND. Ground/dc common connection.
- PWR. Power, 10 to 30V dc power connection.
- TIN, TIP. Not used. Do not make any wiring connections to these terminals.
- Ignore alternate labeling referring to other models that use this board.

Terminal Block (IP20 Housing)

For the DX8x...C models, PWR in the wiring diagram refers to V+ on the wiring board and GND in the wiring diagram refers to V- on the wiring board. Ignore alternate labeling referring to other models that use this board.

FlexPower Discrete Models	FlexPower Serial Interface Models	FlexPower Counter Models
B+. 3.6 to 5.5V dc (for battery powered models only).	B+. 3.6 to 5.5V dc (for battery powered models only).	B+. 3.6 to 5.5V dc (for battery powered models only).
DIx. Discrete IN x.	CMx. Serial interface connection. For non-serial interface models, do not make any wiring connections to these terminals.	CIx. Counter IN x.
DOx. Discrete OUT x.	DIx. Discrete IN x.	DIx. Discrete IN x.
RX/-. Serial comms line	DOx. Discrete OUT x.	DOx. Discrete OUT x.
SPx. Switch Power. Provides variable power sources for external devices.	RX/-. Serial comms line	RX/-. Serial comms line
TX/+. Serial comms line	SPx. Switch Power. Provides variable power sources for external devices.	SPx. Switch Power. Provides variable power sources for external devices.
V+. Power, 10 to 30V dc power connection.	TX/+. Serial comms line	TX/+. Serial comms line
V-. Ground/dc common connection.	V+. Power, 10 to 30V dc power connection.	V+. Power, 10 to 30V dc power connection.
	V-. Ground/dc common connection.	V-. Ground/dc common connection.

Wiring Diagrams for Discrete Inputs

Connecting dc power to the communication pins will cause permanent damage. For the DX8x...C models, PWR in the wiring diagram refers to V+ on the wiring board and GND in the wiring diagram refers to V- on the wiring board.

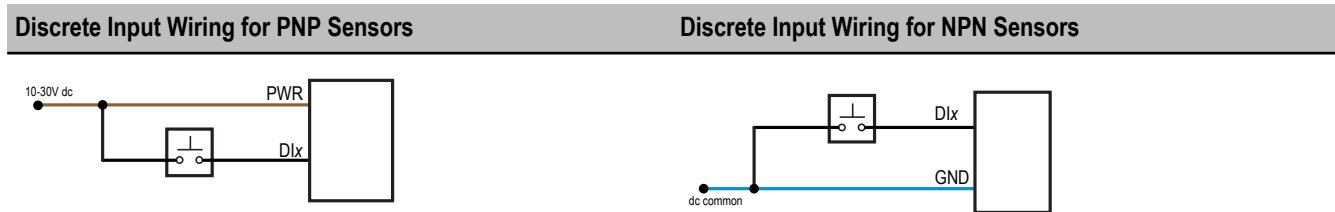

Wiring Diagrams for Discrete Outputs

Connecting dc power to the communication pins will cause permanent damage. For the DX8x...C models, PWR in the wiring diagram refers to V+ on the wiring board and GND in the wiring diagram refers to V- on the wiring board.

Discrete Output Wiring (NPN or NMOS)

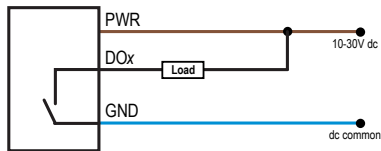

Wiring Diagrams for Counter Inputs

Connecting dc power to the communication pins will cause permanent damage. For the DX8x...C models, PWR in the wiring diagram refers to V+ on the wiring board and GND in the wiring diagram refers to V- on the wiring board.

Counter Inputs (Sourcing/PNP)

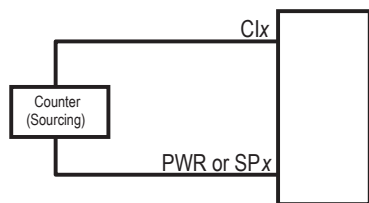

Counter Inputs (Sinking/NPN)

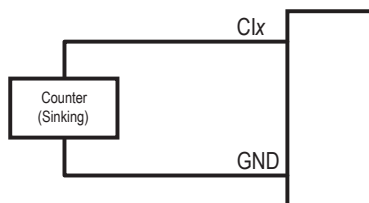

LED Behavior for the Nodes

After powering up and binding the Gateway and its Nodes, verify all devices are communicating properly. A Node will not sample its inputs until it is communicating with its Gateway. When testing communication between the Gateway and Node, all radios and antennas should be at least two meters apart or the communications may fail.

LED 1	LED 2	Node Status
(flashing green)		Radio Link Ok
(flashing red)	(flashing red)	Device Error
	(flashing red, 1 per 3 sec)	No Radio Link

Modbus Register Table (Event and Rate Counter)

I/O	Modbus Holding Register		I/O Type	I/O Range		Holding Register Representation		Terminal Block Labels
	Gateway	Any Node		Min.	Max.	Min. (Dec.)	Max. (Dec.)	
1	1	1 + (Node# × 16)	Discrete IN 1	0	1	0	1	DI1
2	2	2 + (Node# × 16)	Discrete IN 2	0	1	0	1	DI2
3	3	3 + (Node# × 16)	Event Count 1 (high)**	0	65535	0	65535	CI1
4	4	4 + (Node# × 16)	Event Count 1 (low)**	0	65535	0	65535	
5	5	5 + (Node# × 16)	Rate Count (Hz)	0	65535	0	65535	CI2
6	6	6 + (Node# × 16)						
7	7	7 + (Node# × 16)	Reserved					
8	8	8 + (Node# × 16)	Device Message					
9	9	9 + (Node# × 16)	Discrete OUT 1	0	1	0	1	DO1
10	10	10 + (Node# × 16)	Discrete OUT 2	0	1	0	1	DO2

I/O	Modbus Holding Register		I/O Type	I/O Range		Holding Register Representation		Terminal Block Labels
	Gateway	Any Node		Min.	Max.	Min. (Dec.)	Max. (Dec.)	
11	11	11 + (Node# × 16)	Clear Counter 1	0	1	0	1	
12	12	12 + (Node# × 16)						
13	13	13 + (Node# × 16)	Clear Counter 2	0	1	0	1	
14	14	14 + (Node# × 16)						
15	15	15 + (Node# × 16)	Control Message					
16	16	16 + (Node# × 16)	Reserved					

** Two consecutive 16-bit unsigned registers are combined to represent one 32-bit unsigned number for a maximum total count of 4,294,967,295.

High word (I/O 3)

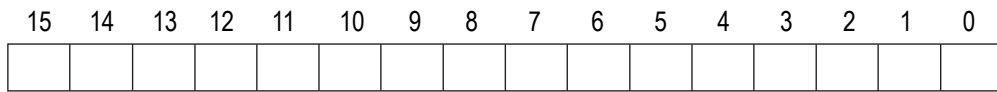

+

Low word (I/O 4)

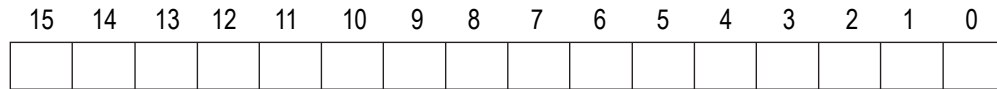

Modbus Register Table (Two Event Counters)

I/O	Modbus Holding Register		I/O Type	I/O Range		Holding Register Representation		Terminal Block Labels
	Gateway	Any Node		Min.	Max.	Min. (Dec.)	Max. (Dec.)	
1	1	1 + (Node# × 16)	Discrete IN 1	0	1	0	1	DI1
2	2	2 + (Node# × 16)	Discrete IN 2	0	1	0	1	DI2
3	3	3 + (Node# × 16)	Event Count 1 (high)**	0	65535	0	65535	CI1
4	4	4 + (Node# × 16)	Event Count 1 (low)**	0	65535	0	65535	
5	5	5 + (Node# × 16)	Event Count 2 (high)**	0	65535	0	65535	CI2
6	6	6 + (Node# × 16)	Event Count 2 (low)**	0	65535	0	65535	
7	7	7 + (Node# × 16)	Reserved					
8	8	8 + (Node# × 16)	Device Message					
9	9	9 + (Node# × 16)	Discrete OUT 1	0	1	0	1	DO1
10	10	10 + (Node# × 16)	Discrete OUT 2	0	1	0	1	DO2
11	11	11 + (Node# × 16)	Clear Counter 1	0	1	0	1	
12	12	12 + (Node# × 16)						
13	13	13 + (Node# × 16)	Clear Counter 2	0	1	0	1	
14	14	14 + (Node# × 16)						
15	15	15 + (Node# × 16)	Control Message					

I/O	Modbus Holding Register		I/O Type	I/O Range		Holding Register Representation		Terminal Block Labels
	Gateway	Any Node		Min.	Max.	Min. (Dec.)	Max. (Dec.)	
16	16	16 + (Node# × 16)	Reserved					

** Two consecutive 16-bit unsigned registers are combined to represent one 32-bit unsigned number for a maximum total count of 4,294,967,295.

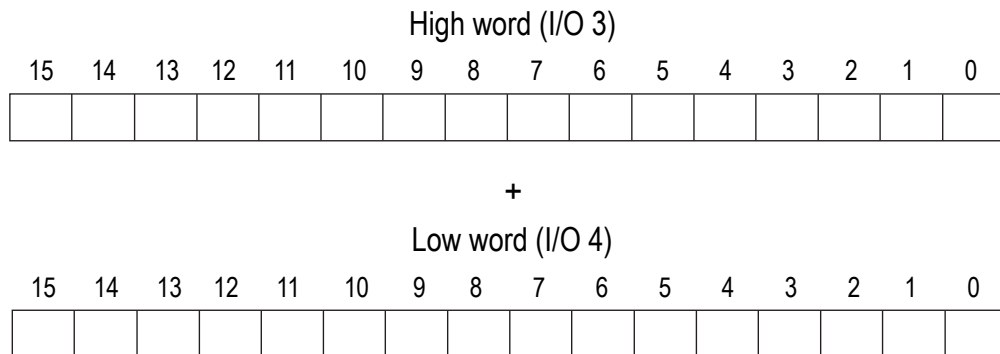

Event Counter Presets

The event counter input can be preset from the Node menu system or from a host system using Advanced Control Messages. The LCD menu system on the Node allows the user to preset event counter values on each available counter input. From the host system, each device has allocated Node registers 7, 15, and 16 that send preset data to the event counter. When power is applied to the Node, the counter value is reset to the last saved value. The counter value is saved every hour.

Setting the counter using the preset or clear functions saves the preset value or zeroes in EEPROM.

Host Control Counter Preset

The event counter input is a 32-bit value that can be preset using the parameter control codes 143 (0x8F) and 144 (0x90). Parameter control code 143 writes the lower half [15:0] of the counter and code 144 writes the upper half [31:16] of the counter.

Select which counter to preset by defining the Counter Select Mask. The first bit position of the mask (bit 0, right justified) selects the first counter and the second bit position selected the second counter. Set the Node's register 16 to the high or low data value. Read Node register 7 for the transfer acknowledgement. Write to Node register 16 before writing to Node register 15.

There are 16 Modbus holding registers for each SureCross™ device. To calculate the registers for other Nodes, use this equation: Register number = I/O# + (Node # × 16). For example, the Gateway is always device 0 (or Node 0), so the Gateway's holding registers are registers 1 through 16. The registers for Node 1 are 17 through 32 and the registers for Node 2 are 33 through 48.

Node Reg 16	Low or High Value	
Node Reg 15	143 or 144 (0x8F or 0x90)	Counter Select Mask
Node Reg 7	Acknowledge Code 143 or 144	Acknowledge Counter Select Mask

Example: To preset Node 2's counter 2 to the value 20,567,001 (hex 0139 D3D9), follow these steps:

1. Write the upper word to the counter using control code 144 (0x90).

Node Reg 48	0139	
Node Reg 47	0x90	2
Node Reg 39	0x90	2

2. Write the lower word to the counter using control code 143 (0x8F).

Node Reg 48	D3D9	
Node Reg 47	0x8F	2

Node Reg 39	0x8F	2
-------------	------	---

The counter has been preset to 20,567,001 (0x0139 D3D9)

Preset Using the Node's Menu System

To manually enter a counter preset, follow the LCD menu flow using the diagram shown.

1. Single click button 1 to move across the top level menus. Click button 1 until the display shows IOCFG.
2. Click button 2 to enter the I/O Configuration submenu structure.
3. Single click button 1 to move across the I/O points. Single click button 2 to enter the preset configuration for the desired I/O point. I/O 3 is the event counter and I/O 5 is the rate counter.
4. The screen displays the counter number, usually CNTR 1 or CNTR 2. Single click button 2 to move down the menu structure.
5. Use the right rotary switch to begin setting the counter preset. Digit selection begins with the least significant digit (the right-most digit). After selecting the least significant digit of the counter preset, single click button 1 to advance left to the next significant digit.
6. Use the right rotary switch to select the second digit. Single click button 1 to advance to the next digit.
7. When the counter preset has been entered, single click button 2 to save the value. The second screen of counter preset digits displays only when more than four digits are necessary. The preset counter may be set from zero to 4,000,000,000.
8. Double click button 2 to exit this menu. If you try to leave this menu without resetting the rotary switch back to its network address position, the menu system prompts you to correct the switch setting before returning to RUN mode. The prior network address setting displays.
9. Single click button 2 to enter the new network address. The new address is confirmed.
10. Single click button 2 to save the network address and return to the IOCFG menu and RUN mode.

Clearing the Event Counter

The counter Nodes can clear the counter values from a mapped input signal or from a host system writing to a Modbus register. For example, a push button on a Gateway can be mapped to Node register 11 to clear a counter when the button is pressed.

From a host system, reset the counter by writing a 1 to Node register 11 for counter 1 or Node register 13 for counter 2.

Setting the counter using the preset or clear functions saves the preset value or zeroes in EEPROM.

Counter Node Menu Structure

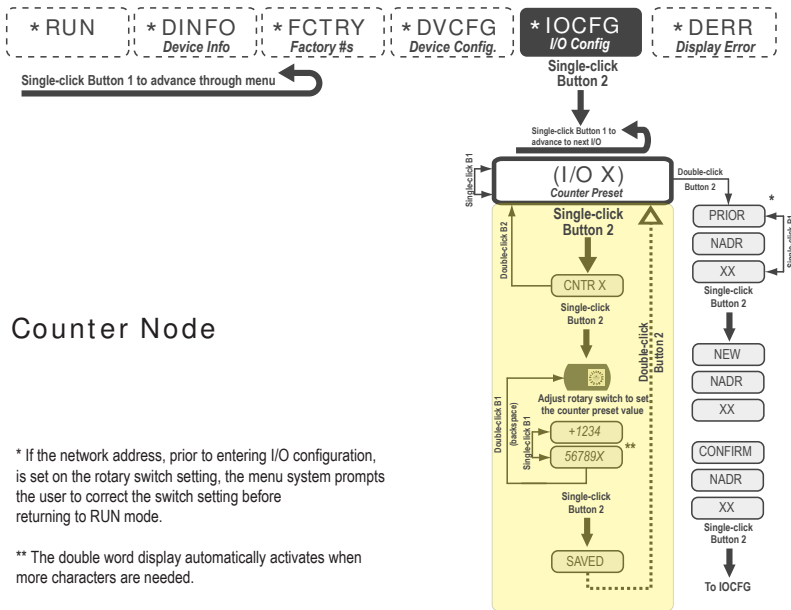

Specifications

Radio and General

Range

- 900 MHz: Up to 4.8 kilometers (3 miles)
- 2.4 GHz: Up to 3.2 kilometers (2 miles)

Transmit Power

- 900 MHz: 21 dBm conducted
- 2.4 GHz: 18 dBm conducted, less than or equal to 20 dBm EIRP

900 MHz Compliance (150 mW Radios)

- FCC ID TGUDX80 - This device complies with FCC Part 15, Subpart C, 15.247
- IC: 7044A-DX8009

2.4 GHz Compliance

- FCC ID UE300DX80-2400 - This device complies with FCC Part 15, Subpart C, 15.247
- ETSI/EN: In accordance with EN 300 328: V1.7.1 (2006-05)
- IC: 7044A-DX8024

Spread Spectrum Technology

- FHSS (Frequency Hopping Spread Spectrum)

Link Timeout

- Gateway: Configurable
- Node: Defined by Gateway

Radio range is with the 2 dB antenna that ships with the product. High-gain antennas are available, but the range depends on the environment and line of sight. To determine the range of your wireless network, perform a Site Survey.

Power

- Requirements: +10 to 30V dc or +3.6 to 5.5V dc low power option (Outside the USA: +12 to 24V dc, $\pm 10\%$ or +3.6 to 5.5V dc low power option)
- Consumption: Less than 1.4 W (60 mA) at 24V dc

Housing

- Polycarbonate housing and rotary dial cover; polyester labels; EDPM rubber cover gasket; nitrile rubber, non-sulphur cured button covers
- Weight: 0.26 kg (0.57 lbs)
- Mounting: #10 or M5 (SS M5 hardware included)
- Max. Tightening Torque: 0.56 N·m (5 lbf·in)

Antenna Connection

- Ext. Reverse Polarity SMA, 50 Ohms
- Max Tightening Torque: 0.45 N·m (4 lbf·in)

Interface

- Indicators: Two bi-color LEDs
- Buttons: Two
- Display: Six character LCD

Wiring Access

- Four PG-7, One 1/2-inch NPT, One 5-pin Euro-style male connector

For European applications, power the DX80 from a Limited Power Source as defined in EN 60950-1.

Inputs and Outputs

Discrete Input Rating

- 3 mA max current at 30V dc

Discrete Input Sample/Report Rates

- 125 milliseconds

Discrete Input ON Condition

- PNP: Greater than 8V
- NPN: Less than 0.7V

Discrete Input OFF Condition

- PNP: Less than 5V
- NPN: Greater than 2V or open

Counter Inputs

- Threshold: 1.5V or 0.25V (Sinking or sourcing selected inputs require the 1.5V threshold setting)
- Debounce: DIP Switch Selectable. Enable debounce to filter a noisy input signal that may lead to false triggers.
- Event Counter: Input rating 1 Hz to 10 kHz (For battery powered devices, the recommended input rating is less than 1 kHz)
- Rate (Frequency) Counter: 1 Hz to 25 kHz
- Threshold (sinking counter on Performance and Multi-Hop models) : 1.7V

Discrete Output Rating (NMOS)

- Less than 10 mA max current at 30V dc
- ON-State Saturation: Less than 0.7V at 20 mA

Discrete Output Update Rate

- 1 second

Discrete Output ON Condition

- Less than 0.7V

Discrete Output OFF Condition

- Open

Output State Following Timeout

- De-energized (OFF)

Environmental and Certifications

Rating

DX80 Models: IEC IP67; NEMA 6; (See UL section below for any applicable UL specifications)

DX80...C Models: IEC IP20; NEMA 1 (In a suitable enclosure: Class I, Division 2, Group A, B, C, D; T4 -40 to 80 °C)

Operating Conditions

Temperature: -40 to +85 °C (Electronics); -20 to +80 °C (LCD)

Humidity: 95% max. relative (non-condensing)

Radiated Immunity: 10 V/m, 80-2700 MHz (EN61000-6-2)

Shock and Vibration

IEC 68-2-6 and IEC 68-2-7

Shock: 30g, 11 millisecond half sine wave, 18 shocks

Vibration: 0.5 mm p-p, 10 to 60 Hz

DX80...C (External Wiring Terminal Models)



UL CSA: Class I, Division 2, Groups A, B, C, D (Ex/A Ex nA II T4); Certificate: 1921239



LCIE/ATEX: Zone 2 (II 3G / Ex nA IIC); Certificate: LCIE 10 ATEX 1012 X



Refer to the [SureCross DX80 Wireless I/O Network Product Manual](#) (p/n 132607) for installation and waterproofing instructions. Operating the devices at the maximum operating conditions for extended periods can shorten the life of the device.

Included with Model

The following items ship with the DX80 radios.

- BWA-HW-002: DX80 Access Hardware Kit, containing four PG-7 plastic threaded plugs, four PG-7 nylon gland fittings, four PG-7 hex nuts, one 1/2-inch NPT plug, and one 1/2-inch nylon gland fitting. (Not included with IP20 DX80...C models)
- BWA-HW-001: Mounting Hardware Kit, containing four M5-0.8 x 25mm SS screws, four M5-0.8 x 16mm SS screws, four M5-0.8mm SS hex nuts, and four #8-32 x 3/4" SS bolts
- BWA-HW-003: PTFE tape
- BWA-902-C (900 MHz) or BWA-202-C (2.4 GHz): Antenna, 2 dBd Omni, Rubber Swivel RP-SMA Male. (Not included with Internal antenna models)
- Quick Start Guide (128185 for DX80 Gateways or 152653 for MultiHop models)
- MQDC1-506: 5-Euro (single ended) straight cable, 2m (Not included with FlexPower devices)
- BWA-HW-011: IP20 Screw Terminal Headers (2 pack) (Included only with the IP20 DX80...C models)

Warnings

Antenna Installations. Install and properly ground a qualified surge suppressor when installing a remote antenna system. Remote antenna configurations installed without surge suppressors invalidate the manufacturer's warranty. Keep the ground wire as short as possible and make all ground connections to a single-point ground system to ensure no ground loops are created. No surge suppressor can absorb all lightning strikes; do not touch the SureCross® device or any equipment connected to the SureCross device during a thunderstorm.

Exporting SureCross Radios. It is our intent to fully comply with all national and regional regulations regarding radio frequency emissions. **Customers who want to re-export this product to a country other than that to which it was sold must ensure the device is approved in the destination country.** A list of approved countries appears in the *Radio Certifications* section of the product manual. The SureCross wireless products were certified for use in these countries using the antenna that ships with the product. When using other antennas, verify you are not exceeding the transmit power levels allowed by local governing agencies. Consult with Banner Engineering Corp. if the destination country is not on this list.

Violating Warnings. The manufacturer does not take responsibility for the violation of any warning listed in this document. **Make no modifications to this product;** any modifications to this product not expressly approved by Banner Engineering could void the user's authority to operate the product. **All specifications published in this document are subject to change;** Banner reserves the right to modify product specifications or to update documentation at any time. For the most recent version of any documentation, refer to: www.bannerengineering.com. © 2006-2013 Banner Engineering Corp. All rights reserved.

Banner Engineering Corp Limited Warranty

Banner Engineering Corp. warrants its products to be free from defects in material and workmanship for one year following the date of shipment. Banner Engineering Corp. will repair or replace, free of charge, any product of its manufacture which, at the time it is returned to the factory, is found to have been defective during the warranty period. This warranty does not cover damage or liability for misuse, abuse, or the improper application or installation of the Banner product.

THIS LIMITED WARRANTY IS EXCLUSIVE AND IN LIEU OF ALL OTHER WARRANTIES WHETHER EXPRESS OR IMPLIED (INCLUDING, WITHOUT LIMITATION, ANY WARRANTY OF MERCHANTABILITY OR FITNESS FOR A PARTICULAR PURPOSE), AND WHETHER ARISING UNDER COURSE OF PERFORMANCE, COURSE OF DEALING OR TRADE USAGE.

This Warranty is exclusive and limited to repair or, at the discretion of Banner Engineering Corp., replacement. **IN NO EVENT SHALL BANNER ENGINEERING CORP. BE LIABLE TO BUYER OR ANY OTHER PERSON OR ENTITY FOR ANY EXTRA COSTS, EXPENSES, LOSSES, LOSS OF PROFITS, OR ANY INCIDENTAL, CONSEQUENTIAL OR SPECIAL DAMAGES RESULTING FROM ANY PRODUCT DEFECT OR FROM THE USE OR INABILITY TO USE THE PRODUCT, WHETHER ARISING IN CONTRACT OR WARRANTY, STATUTE, TORT, STRICT LIABILITY, NEGLIGENCE, OR OTHERWISE.**

Banner Engineering Corp. reserves the right to change, modify or improve the design of the product without assuming any obligations or liabilities relating to any product previously manufactured by Banner Engineering Corp.



more sensors, more solutions

www.bannerengineering.com - tel: 763-544-3164