



CODE 47 - HEAT SHRINK BOOT BACKSHELL

202M712-19B-D

SERIES _____
 ORDER NUMBER (TABLE 1) _____
 MATERIAL _____
 REFER TO CH00-0250-004
 FINISH _____
 REFER TO CH00-0250-004
 MODIFICATION CODE _____
 REFER TO CH00-0250-004

NOTES:

1. THIS PRODUCT IS DESIGNED TO TERMINATE A HEAT SHRINKABLE LIPPED BOOT TO A CONNECTOR.
2. FOR ADDITIONAL DIMENSIONS, ORDERING INFORMATION AND MODIFICATIONS, SEE CH00-0250-004.
3. BACKSHELL TO BE PERMANENTLY MARKED/BAGGED AND LABELLED WITH CODE IDENTIFICATION NUMBER AND PART NUMBER. (e.g. 06090-202M712-19B).
4. KNURL INSIDE BOOT GROOVE MAY BE SUPPLIED AT MANUFACTURER'S OPTION.
- ⑤ BACKSHELL MATES TO BENDIX SJT COMMERCIAL SERIES CONNECTOR.

DRAWN	W.RUST	DATE 14/09/2015	 3RD ANGLE PROJECTION NOT TO SCALE	TITLE:	HEAT SHRINK BOOT BACKSHELL	 Polamco  TE <small>connectivity</small>
CHECKED		14/09/2015				
APPROVED	K.SHEPPARD	09/10/2015		<small>UNLESS OTHERWISE SPECIFIED ALL DIMENSIONS IN MILLIMETRES</small> GENERAL TOL <small>LINEAR +/-0.25MM ANGULAR +/- 1°</small>		
APPROVED	H.SMITH	26/10/2015				
REVISIONS						
LTR	DESCRIPTION	DATE	APPROVED			
C	REVISED PER ECN AD93096					
D	REVISED PER ECO-15-015326	26/10/2015	H.SMITH			
TE CAGE CODE: 06090 POLAMCO/TE CAGE CODE: U5792				<small>TE CONNECTIVITY - POLAMCO LTD RESERVES THE RIGHT TO AMEND THIS DRAWING AND THE INFORMATION SET FORTH HEREON AT ANY TIME. USERS SHOULD INDEPENDENTLY EVALUATE THE SUITABILITY OF THE PRODUCT FOR THEIR APPLICATION.</small>		DRAWING NO: 202M7XX
				DRAWING REV: D	SHT 1	

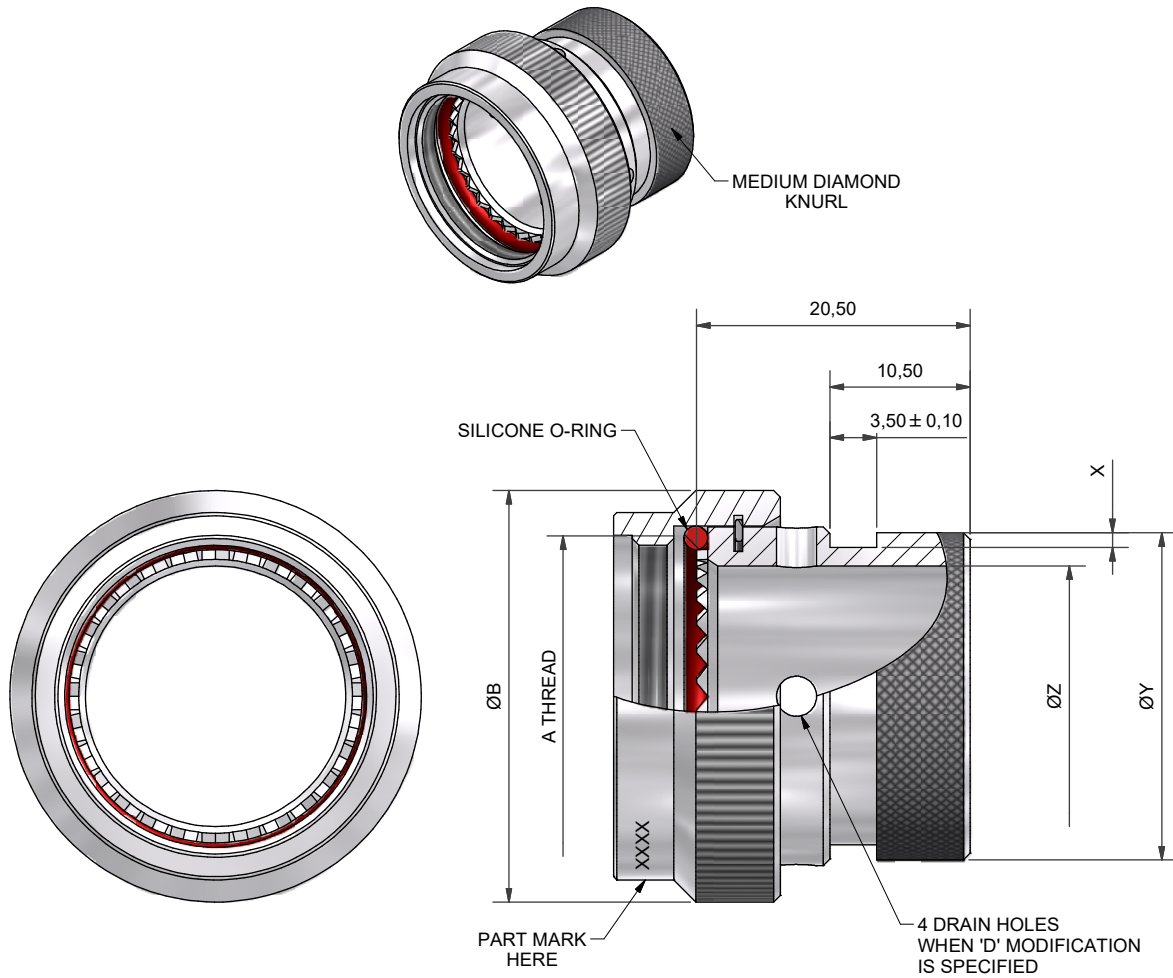



TABLE 1

BASE PART NUMBER	SHELL SIZE		A THREAD	ØB MAX	X +0,20/-0,00	ØY +0,00/-0,50	ØZ MIN
	SJT*00 SJT*06	SJT07R1 ONLY					
202M708	8		7/16-28UNEF	18,0	1,12	13,50	6,10
202M710	10	8	9/16-24UNEF	21,0	1,12	15,40	9,02
202M712	12	10	11/16-24UNEF	24,5	1,12	19,70	12,45
202M714	14	12	13/16-20UNEF	27,8	1,12	21,30	14,86
202M716	16	14	15/16-20UNEF	30,8	1,12	24,50	18,03
202M718	18	16	1 1/16-18UNEF	34,1	1,12	26,50	20,04
202M720	20	18	1 3/16-18UNEF	38,0	1,75	31,00	23,22
202M722	22	20	1 5/16-18UNEF	41,0	1,75	34,40	26,39
202M724	24	24	1 7/16-18UNEF	43,7	1,75	36,60	29,31

DRAWN	W.RUST	DATE 14/09/2015	 3RD ANGLE PROJECTION NOT TO SCALE UNLESS OTHERWISE SPECIFIED ALL DIMENSIONS IN MILLIMETRES GENERAL TOL LINEAR +/-0,25MM ANGULAR +/- 1°
CHECKED		14/09/2015	
APPROVED	K.SHEPPARD	09/10/2015	
APPROVED	H.SMITH	26/10/2015	
REVISIONS			
LTR	DESCRIPTION	DATE	APPROVED
C	REVISED PER ECN AD93096		
D	REVISED PER ECO-15-015326	26/10/2015	H.SMITH

TITLE:
HEAT SHRINK BOOT BACKSHELL

ASSY USED ON:
BENDIX SJT COMMERCIAL SERIES CONNECTOR



TE CAGE CODE: 06090
POLAMCO/TE CAGE CODE: U5792

TE CONNECTIVITY - POLAMCO LTD RESERVES THE RIGHT TO AMEND THIS DRAWING AND THE INFORMATION SET FORTH HEREON AT ANY TIME. USERS SHOULD INDEPENDENTLY EVALUATE THE SUITABILITY OF THE PRODUCT FOR THEIR APPLICATION.

DRAWING NO: 202M7XX	DRAWING REV: D	SHT 2
--------------------------------------	---------------------------------	------------------------