

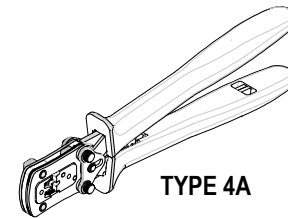

**HAND CRIMP
TOOL**

**Application Tooling
Specification Sheet**



**Hand Crimp Tool
Order No. 63811-3800**

FEATURES

- % A full cycle ratcheting hand tool ensures complete crimps
- % Ergonomically designed soft handles
- % Precisely designed crimping profiles with simple contact positioning
- % Easy handling due to outstanding force ratio

SCOPE

Products: 10.00mm (.393") Pitch Mini-Fit Sr.™ Male and Female Grounding Crimp Terminals, 14-16 AWG.

Terminal Series No.	Terminal Order No.			Wire Size		Insulation Diameter Maximum		Strip Length	
	● Reel			AWG	mm ²	mm	In.	mm	In.
42815	42815-0040	42815-0041	42815-0042	14-16	N/A	3.33	.131	4.25-4.75	.167-.187
	42815-0048	42815-0049	42815-0144						
42817	42817-0040	42817-0041	42817-0042	14-16	N/A	3.33	.131	4.25-4.75	.167-.187
	42817-0048	42817-0049	42817-0140						
	42817-0141	42817-0142	42817-0149						
	42817-1044	42817-1144							

● Customer to cut off terminal from reel: 0.50mm (.020") maximum Cut-off Tab.
*Crimp terminals to stranded copper wire only.

DEFINITION OF TERMS

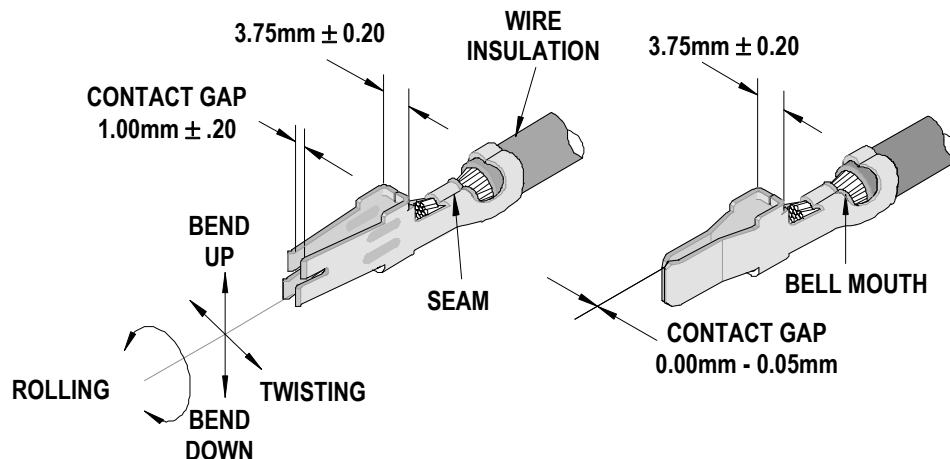

The above terminal drawing is a generic terminal representation. It is not an image of a terminal listed in the scope.

CRIMP SPECIFICATION

After crimping, the crimp profiles should measure the following (see notes on page 3).

Terminal Series No.	Wire Size		Conductor Crimp				Insulation Crimp		Pull Force Minimum		Profile	
			Height (REF)		Width (Ref)		Width (Ref)		N	Lb.	A	B
	AWG	mm ²	mm	In.	mm	In.	mm	In.				
42815	14	N/A	1.89-1.99	.074-.078	3.20	.126	4.50	.177	222.4	50.00	X	
	16	N/A	1.82-1.92	.072-.075	3.20	.126	4.50	.177	133.4	30.00		X
42817	14	N/A	1.89-1.99	.074-.078	3.20	.126	4.50	.177	222.4	50.00	X	
	16	N/A	1.82-1.92	.072-.075	3.20	.126	4.50	.177	133.4	30.00		X

OPERATION

Open the tool by squeezing the handles together, at the end of the closing stroke, the ratchet mechanism will release the handles, and the hand tool will spring open.

Crimping Terminals

1. Place the terminal into the correct die profile (A or B) until the terminal stopped by the locator.
2. Partially close the tool until the terminal is held in place.
3. Place a pre-stripped wire into the terminal and align the wire with the conductor and insulation grips visually. See Figure 2 and 3.
4. Close the tool until the ratchet releases.
5. Carefully remove the crimped terminal.

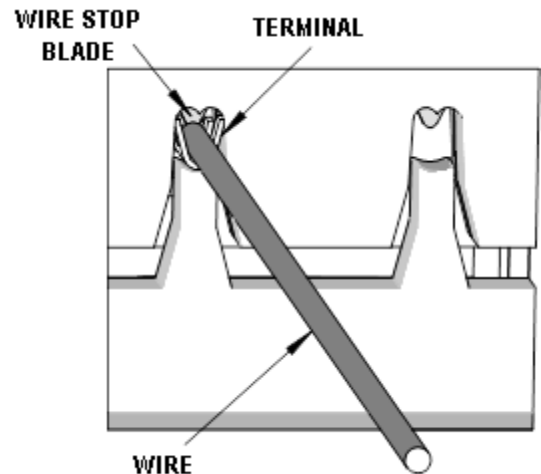

Figure 1

Note: The tamper proof ratchet action will not release the tool until it has been fully closed.

Maintenance

It is recommended that each operator of the tool be made aware of, and responsible for, the following maintenance steps:

1. Remove dust, moisture, and other contaminants with a clean brush, or soft, lint free cloth.
2. Do not use any abrasive materials that could damage the tool.
3. Make certain all pins; pivot points and bearing surfaces are protected with a thin coat of high quality machine oil. Do not oil excessively. The tool was engineered for durability but like any other equipment it needs cleaning and lubrication for a maximum service life of trouble free crimping. Light oil (such as 30 weight automotive oil) used at the oil points, every 5,000 crimps or 3 months, will significantly enhance the tool life.
4. Wipe excess oil from hand tool, particularly from crimping area. Oil transferred from the crimping area onto certain terminations may affect the electrical characteristics of an application.
5. When tool is not in use, keep the handles closed to prevent objects from becoming lodged in the crimping dies, and store the tool in a clean, dry area.

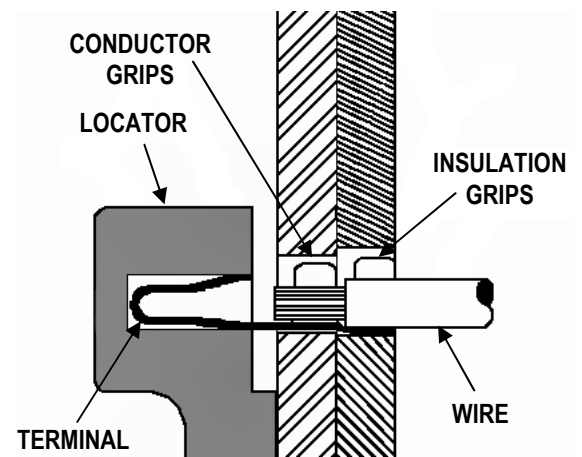

Figure 2

Miscrimps or Jams

Should this tool ever become stuck or jammed in a partially closed position, **Do Not force the handles open or closed**. The tool will open easily by lifting the ratchet release lever. See Figure 6.



Warranty

This tool is for electrical terminal crimping purposes only. This tool is made of the best quality materials. All vital components are long life tested. All tools are warranted to be free of manufacturing defects for a period of 30 days. Should such a defect occur, we will repair or exchange the tool free of charge. This repair or exchange will not be applicable to altered, misused, or damaged tools. This tool is designed for hand use only. Any clamping, fixturing, or use of handle extensions voids this warranty.

CAUTION: Repetitive use of this tool should be avoided.

CAUTIONS:

1. Manually powered hand tools are intended for low volume or field repair. This tool is **NOT** intended for production use. Repetitive use of this tool should be avoided.
2. Insulated rubber handles are not protection against electrical shock.
3. Wear eye protection at all times.
4. Use only the Molex terminals specified for crimping with this tool.

 CAUTION	<p>Molex tooling crimp specifications are valid only when used with Molex terminals and tooling manufactured by Molex or authorized distributors (“Molex Tooling”). When using tooling other than Molex Tooling with specific Molex specific connector systems listed in our ATS documents, the Molex tooling qualification does not apply and the responsibility for full qualification of the connector system is that of the customer.</p> <p>Molex accepts no liability for connector performance or tooling support where tooling other than Molex Tooling is used, or where Molex Tooling is modified.</p>
 CAUTION	<p>A-620 and other industry standards do not supersede the manufacturer’s specifications. Some terminals designed over 20 years ago may not meet the desired physical attributes for some of today’s standards. However, these terminals will still perform electrically at an acceptable quality level based on the qualification testing and years of successful performance in the field.</p>

Notes:

1. This tool should only be used for the terminals and wire gauges specified on this sheet.
2. This tool is not adjustable for crimp height; however crimp force is adjustable (See instructions above). Variations in tools, terminals, wire stranding, and insulation types may affect crimp height.
3. This tool is intended for standard conductor sizes. It may not give a good insulation crimp support for all insulation sizes.
4. Molex does not repair hand tools (see warranty above). The replacement parts listed are the only parts available for repair. If the handles or crimp tooling is damaged or worn, a new tool must be purchased.
5. Pull force should be used as the final criteria for an acceptable crimp. Pull force is measured with no influence from the insulation crimp. The insulation should be stripped long (1/2 in.) so the insulation grips on the terminal do not grip the wire insulation or the conductor. Refer to Molex Quality Crimping Handbook 63800-0029 for additional information on crimping and crimp testing.
6. Molex does not certify crimp hand tools.

PARTS LIST

Item	Order Number	Description	Quantity
1	63600-0520	Crimping Spring	2
2	63811-3875	Locator	1
3	63600-0525	Handle Spring	1

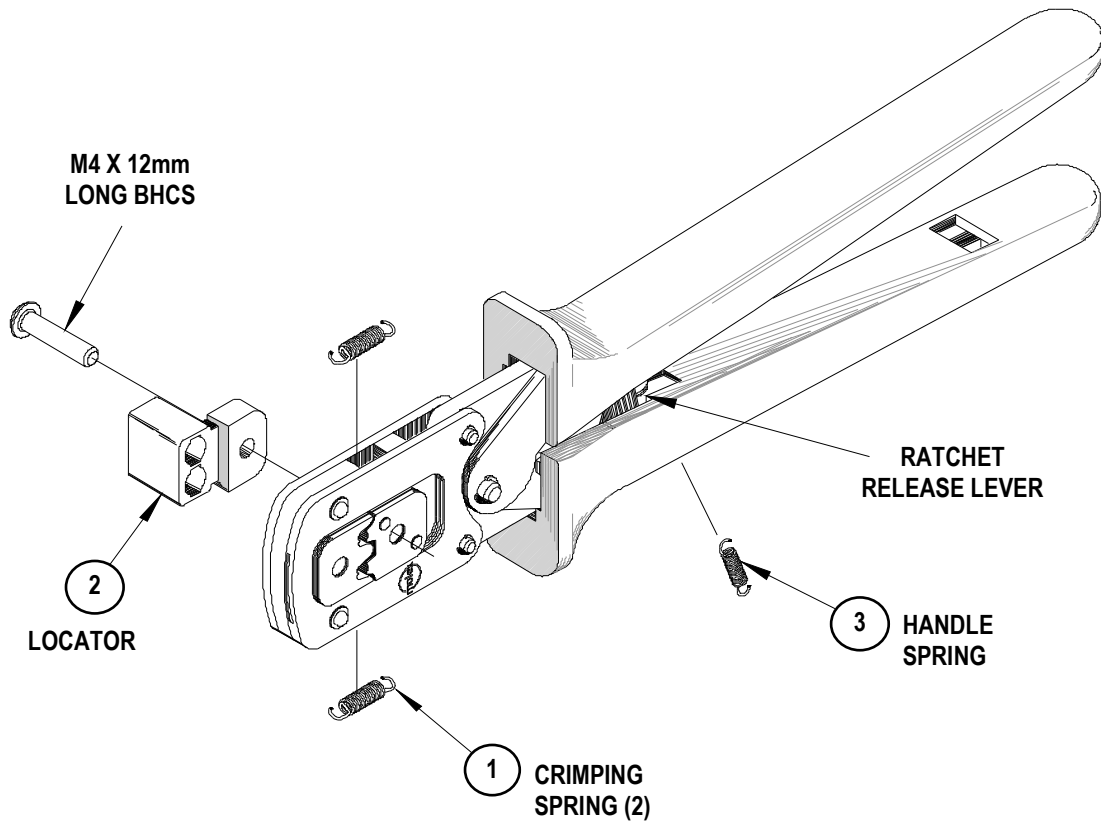

Figure 3

Application Tooling Support
 2200 Wellington Court
 Lisle, IL 60532 USA
 Direct +1-402-458-TOOL (8665)

Visit our website at www.molex.com/applicationtooling