

Signal Chain Power LT3472 Dual Output Converter

DESCRIPTION

Demonstration circuit SCP-LT3472-EVALZ is a dual output converter featuring the LT3472EDD. The Boost Converter is designed to convert a 2.7V–4.2V input to 15V output at 25mA–45mA load. The Inverting Circuit generates a –8V output at 35mA–65mA from the same input.

Like all boards in the Signal Chain Power series, this board is designed to be easily plugged into other SCP boards to form a complete signal chain power system, enabling fast evaluation of low power signal chains. To evaluate this board, some universal SCP hardware is required, namely:

- SCP-INPUT-EVALZ SCP-FILTER-EVALZ
- SCP-OUTPUT-EVALZ SCP-1X2BKOUT-EVALZ
- SCP-1X5BKOUT-EVALZ SCP-5X1-EVALZ
- SCP-THRUBRD-EVALZ

To properly evaluate SCP series demo boards, you will need the SCP Configurator companion software. SCP Configurator can help you choose the right board and topology for your design.

Note that this Demo Manual does not cover details important to the operation and configuration regarding the [LT3472](#). Please refer to the [LT3472 datasheet](#) for a complete description of the part.

Design files for this circuit board are available.

All registered trademarks and trademarks are property of their respective owners.

Table 1. Performance Summary

| SYMBOL | PARAMETER | NOTES | MIN | TYP | MAX | UNITS |
|-----------------------|----------------------|--|------------|------------|-----------|-------|
| V _{IN(MAX)} | Max Input Voltage | | | | 16 | V |
| V _{OUT(MAX)} | Max Output Voltage | Positive V _{OUT} Negative V _{OUT} | | | 34 –34 | V |
| I _{SW(LIM)} | Switch Current Limit | | 250 300 | 350 400 | | mA |

BOARD IMAGE

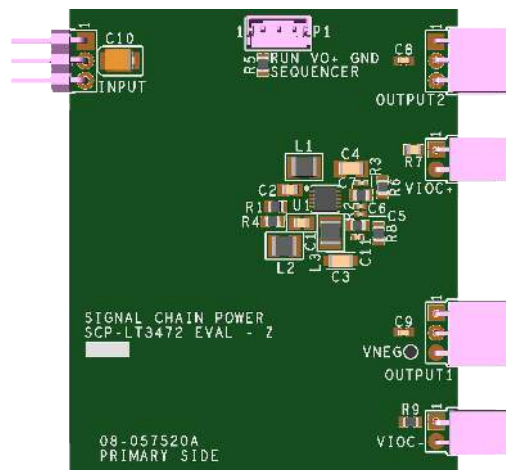

Figure 1. SCP-LT3472-EVALZ Board

DEMO MANUAL SCP-LT3472-EVALZ

QUICK START PROCEDURE

Demonstration circuit SCP-LT3472-EVALZ is easy to set up to evaluate the performance of any SCP hardware configuration.

1. The SCP-LT3472-EVALZ ships with default output voltages of 15V and $-8V$, respectively. To change the output voltage, see “Configuration Settings” section, and modify the board accordingly. Be sure to check for open connections or solder shorts after making any modifications.
2. Connect the SCP-INPUT-EVALZ and SCP-OUTPUT-EVALZ boards to the SCP-LT3472-EVALZ (refer to Figure 2) and connect the input board to a voltage source, V_{SOURCE} . Connect the output board to a voltmeter or dynamic load. Slowly raise the input voltage until the SCP-LT3472-EVALZ powers up into regulation and sweep V_{SOURCE} through the desired range of operation.

NOTE: Make sure that the input voltage is always within spec. If using a dynamic load to measure output voltage, make sure the load is initially set to zero.

3. Check for proper output voltages. The output should be regulated at the programmed value ($\pm 5\%$).
4. Once the proper output voltage is established, power off V_{SOURCE} and similarly test other boards in the SCP system until all elements have been individually verified prior to assembling into the final circuit configuration.

NOTE: When measuring the input or output voltage ripple, use the optional SMA connector locations available on the input, output, 1 \times 5, 1 \times 2, and 5 \times 1 breakout boards. Avoid using the test point connections with long scope leads.

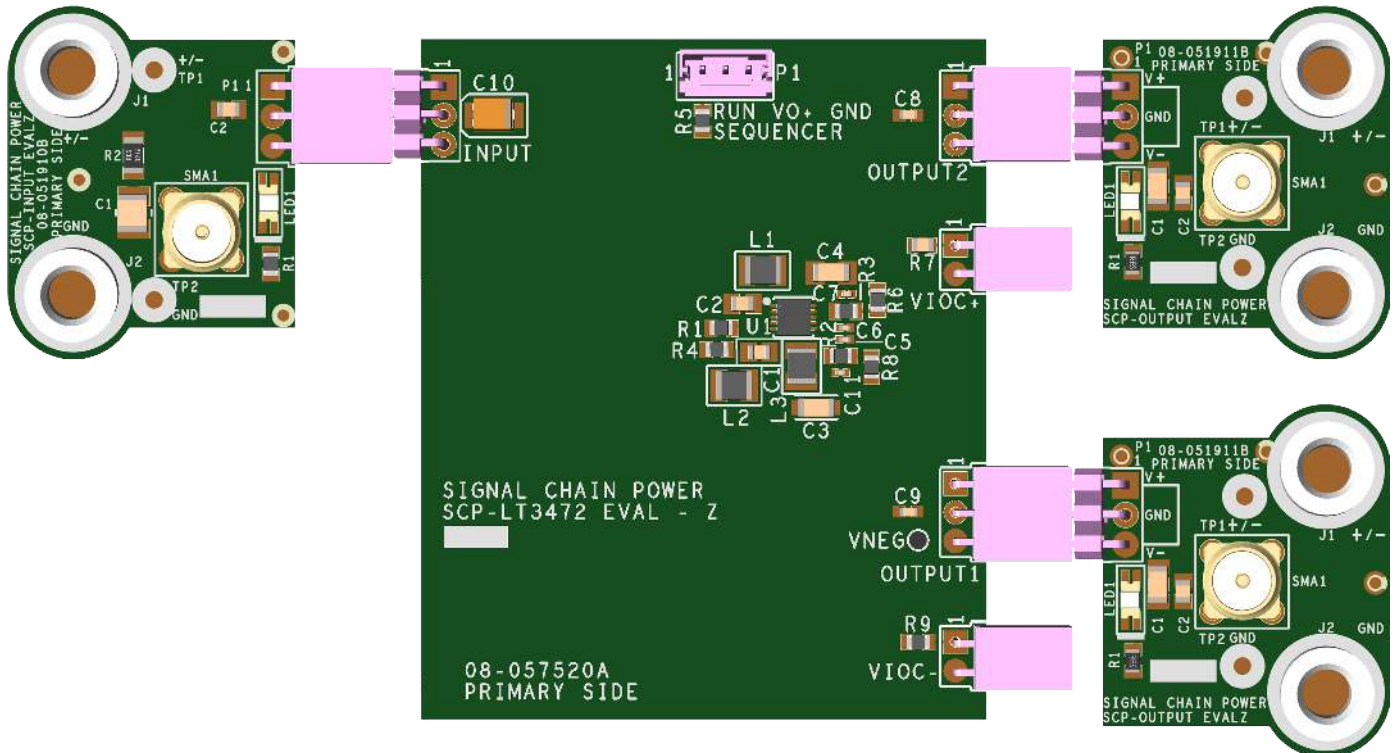

Figure 2. Proper Measurement Equipment Setup (Use SMA connectors for Measuring Input or Output Ripple)

CONFIGURATION SETTINGS

Demonstration circuit SCP-LT3472-EVALZ is a dual output converter featuring the LT3472EDD. The Boost Converter is designed to convert a 2.7V–4.2V input to 15V output at 25mA–45mA load. The Inverting Circuit generates a –8V output at 35mA–65mA from the same input.

Each output of the SCP-LT3472-EVALZ is resistor-programmable from |5V| to |34V|. The board can be also configured to drive VIOC-capable linear regulators.

OUTPUT VOLTAGE

$$V_{OUT1} = 1.25V \left(1 + \frac{R3}{50k} \right)$$

$$V_{OUT2} = -1.25V \left(\frac{R2}{50k} \right)$$

Table 2. Resistor Selection Guide for Common Output Voltages

| V _{OUT1} (V) | R3 (Ω) | V _{OUT2} (V) | R2 (Ω) |
|-------------------------|--------|-------------------------|--------|
| 5.0 | 150k | 5.0 | 200k |
| 5.5 | 169k | 5.5 | 221k |
| 6.0 | 189k | 6.0 | 240k |
| 6.5 | 210k | 6.5 | 261k |
| 7.0 | 229k | 7.0 | 280k |
| 7.5 | 249k | 7.5 | 301k |
| 8.0 | 271k | 8.0 | 320k |
| 8.5 | 291k | 8.5 | 340k |
| 9.0 | 309k | 9.0 | 361k |
| 9.5 | 328k | 9.5 | 379k |
| 10.0 | 348k | 10.0 | 402k |
| 11.0 | 388k | 11.0 | 442k |
| 12.0 | 432k | 12.0 | 481k |
| 13.0 | 470k | 13.0 | 517k |
| 14.0 | 511k | 14.0 | 562k |
| 15.0 | 549k | 15.0 | 597k |
| 16.0 | 590k | 16.0 | 642k |
| 17.0 | 626k | 17.0 | 681k |
| 18.0 | 673k | 18.0 | 723k |
| 19.0 | 706k | 19.0 | 759k |
| 20.0 | 750k | 20.0 | 796k |
| 25.0 | 953k | 25.0 | 1M |
| 30.0 | 1.15M | 30.0 | 1.20M |
| 34.0 | 1.30M | 34.0 | 1.35M |

SHDN PIN CONFIGURATION

The $\overline{\text{SHDN}}$ pin is tied to the optional SCP Run/Sequence header P1. To create a harness for this function, use Molex part 0510650300 with crimp pin 50212-8000.

To use an active run signal, use a 1.00MΩ resistor for either pull-up or pull-down resistors R1 and R4, short R5 with 0Ω, and use the drive signal from connector P1.

VOLTAGE INPUT-TO-OUTPUT CONTROL (VIOC) IMPLEMENTATION

To implement the VIOC function for both regulators, set R7 and R9 to 0Ω, respectively. Refer to the “Configuration Settings” section in the Demo Manual for the low-dropout (LDO) linear regulator board and use the following configuration for this board.

Table 3. VIOC Cross-Reference Designators

| VIOC SETTING REFERENCES | R _{BOT} | R _{TOP} | R _{MAX} |
|--|-------------------|------------------|------------------|
| V _{OUT} Reference Designators for V _{OUT1} | 50k (internal) | R3 | R6 |
| V _{OUT} Reference Designators for V _{OUT2} | 50k (internal) | R2 | R8 |

Positive VIOC Equations

$$V_{LDOIN} - V_{LDOOUT} = V_{VIOC} = 1.25V \left(\frac{R_{BOT} + R_{TOP}}{R_{BOT}} \right)$$

$$V_{(MAX)LDOIN} = 1.25V \left(\frac{R_{BOT} + R_{TOP} + R_{MAX}}{R_{BOT}} \right) + I_{SINK} R_{MAX}$$

I_{SINK} is the current through R_{MAX} which is typically 15μA. Since the divider current is fixed due to the internal low side gain setting feedback resistor and is less than the recommended divider current of 100μA, the effect of the sink current on the maximum linear regulator input voltage cannot not be mitigated and should be taken into consideration.

Negative VIOC Equations

$$V_{LDOIN} - V_{LDOOUT} = V_{VIOC} = -1.25V \left(\frac{R_{TOP}}{R_{BOT}} \right)$$

$$V_{(MAX)LDOIN} = -1.25 \left(\frac{R_{TOP} + R_{MAX}}{R_{BOT}} \right) + V_{VIOC} \left(\frac{R_{MAX}}{40k} \right)$$

Because the V_{LDOIN} term is simply the sum of the final output voltage after the LDO and the difference the LT3472 is adding on top, it can be helpful to take the desired final output voltage, add 1.0V, and then look up that voltage-resistor combination from Table 2.

R_{MAX} can then be obtained by figuring out the difference between the maximum and nominal output voltage of the LT3472, divided by the current through the internal R_{BOT} resistor, which is $1.25V/R_{BOT}$.

DEMO MANUAL SCP-LT3472-EVALZ

PARTS LIST

| ITEM | QTY | REFERENCE | PART DESCRIPTION | MANUFACTURER/PART NUMBER |
|------|-----|------------------|---|------------------------------|
| 1 | 1 | PCB | PCB | ANALOG DEVICES 08_057520a |
| 2 | 1 | C1 | CAP CER X7R | SAMSUNG CL21B105KBFNNNE |
| 3 | 1 | C10 | CAP TANTALUM 3528 (Note 1) | N/A |
| 4 | 1 | C2 | CAP CER X7R | TAIYO YUDEN UMK212BB7225KG-T |
| 5 | 1 | C3 | CAP CER 2.2UF 50V 10% X7R 1206, AUTOMOTIVE | MURATA GCM31CR71H225KA55K |
| 6 | 1 | C4 | CAP CER 4.7UF 50V 10% X7R 1206 | SAMSUNG CL31B475KBHNNNE |
| 7 | 2 | C5, C6 | CAP CER 0.22UF 50V 10% X5R 0402 | TAIYO YUDEN UMK105BJ224KV-F |
| 8 | 2 | C7, C11 | CAP CER 10PF 50V 5% COG 0402, AUTOMOTIVE | MURATA GCM1555C1H100JA16D |
| 9 | 2 | C8, C9 | CAP CER 0.1UF 50V 10% X7R 0603 | SAMSUNG CL10B104KB8NNNC |
| 10 | 1 | INPUT | CONN-PCB MALE HEADER 3POS 2.54MM PITCH R/A GOLD | SULLINS PBC03SBAN |
| 11 | 1 | L1 | IND HF UNSHIELDED WIREWOUND 0.923OHM DCR, 0.25A | WURTH ELEKTRONIK7440329220 |
| 12 | 2 | L2, L3 | IND HF UNSHIELDED WIREWOUND 1.690HM DCR, 0.17A | WURTH ELEKTRONIK7440329470 |
| 13 | 2 | OUTPUT1, OUTPUT2 | CONN FEMALE 3POS 2.54MM PITCH R/A GOLD | SULLINS PPPC031LGBN-RC |
| 14 | 1 | P1 | CONN-PCB 3POS HEADER WIRE TO BRD WAFER ASSY STRAIGHT 2MM PITCH (Note 1) | MOLEX 53253-0370 |
| 15 | 1 | R1 | RES PRECISION THICK FILM CHIP | PANASONIC ERJ-6ENF1003V |
| 16 | 1 | R2 | RES SMD 324k OHM 0.1% 1/8W 0805, AUTOMOTIVE | PANASONIC ERA-6AEB3243V |
| 17 | 1 | R3 | RES SMD 549k OHM 0.1% 1/8W 0805, AUTOMOTIVE | PANASONIC ERA-6AEB5493V |
| 18 | 3 | R4, R6, R8 | RES STANDARD THICK FILM CHIP JUMPER, FOR AUTOMOTIVE | VISHAY CRCW08050000Z0EA |
| 19 | 1 | R5 | RES THICK FILM 0805 (Note 1) | N/A |
| 20 | 2 | R7, R9 | RES THICK FILM 0805 (Note 1) | N/A |
| 21 | 1 | U1 | IC-ADI BOOST AND INVERTING DC/DC CONVERTER FOR CCD BIAS | ANALOG DEVICES LT3472EDD#PBF |
| 22 | 2 | VIOC+, VIOC- | CONN FEMALE 2POS 2.54MM PITCH R/A GOLD | SULLINS PPPC021LGBN-RC |

Note 1. These items are not stuffed (DNI).

DEMO MANUAL SCP-LT3472-EVALZ

SCHEMATIC DIAGRAM

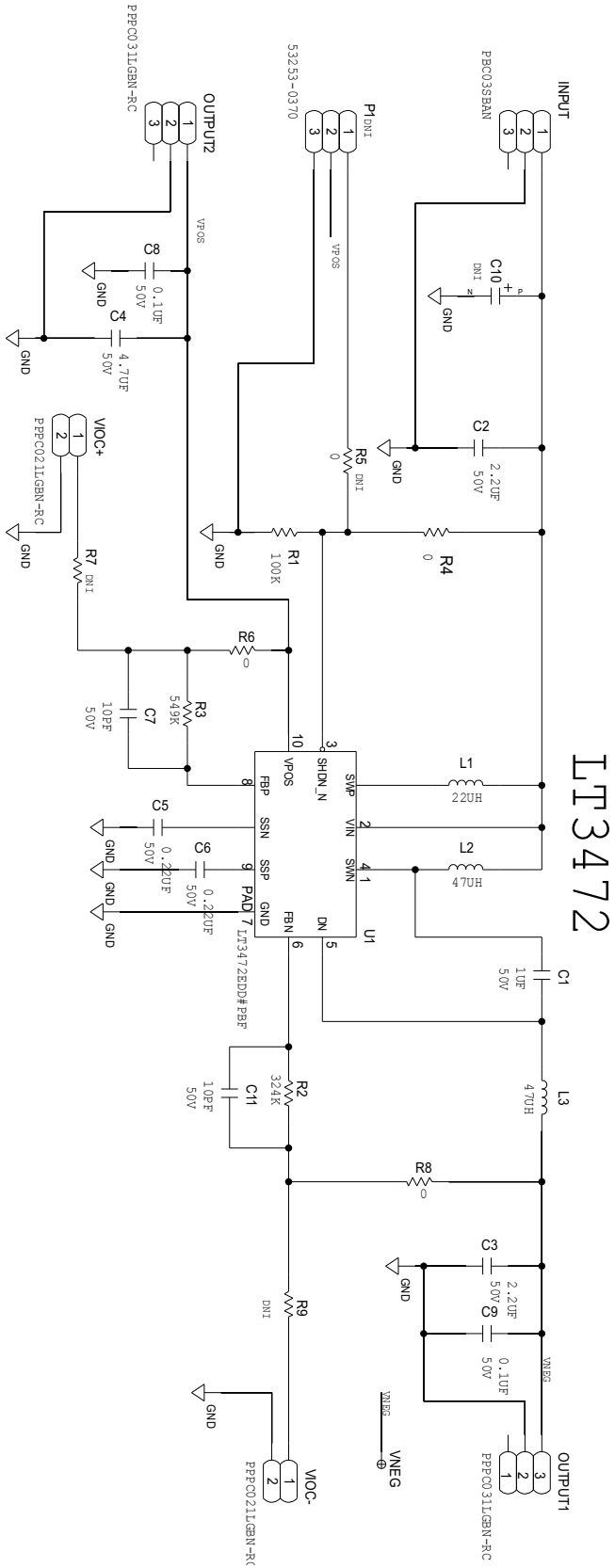

LT3472

DEMO MANUAL SCP-LT3472-EVALZ



ESD Caution

ESD (electrostatic discharge) sensitive device. Charged devices and circuit boards can discharge without detection. Although this product features patented or proprietary protection circuitry, damage may occur on devices subjected to high energy ESD. Therefore, proper ESD precautions should be taken to avoid performance degradation or loss of functionality.

Legal Terms and Conditions

By using the evaluation board discussed herein (together with any tools, components documentation or support materials, the "Evaluation Board"), you are agreeing to be bound by the terms and conditions set forth below ("Agreement") unless you have purchased the Evaluation Board, in which case the Analog Devices Standard Terms and Conditions of Sale shall govern. Do not use the Evaluation Board until you have read and agreed to the Agreement. Your use of the Evaluation Board shall signify your acceptance of the Agreement. This Agreement is made by and between you ("Customer") and Analog Devices, Inc. ("ADI"), with its principal place of business at One Technology Way, Norwood, MA 02062, USA. Subject to the terms and conditions of the Agreement, ADI hereby grants to Customer a free, limited, personal, temporary, non-exclusive, non-sublicensable, non-transferable license to use the Evaluation Board FOR EVALUATION PURPOSES ONLY. Customer understands and agrees that the Evaluation Board is provided for the sole and exclusive purpose referenced above, and agrees not to use the Evaluation Board for any other purpose. Furthermore, the license granted is expressly made subject to the following additional limitations: Customer shall not (i) rent, lease, display, sell, transfer, assign, sublicense, or distribute the Evaluation Board; and (ii) permit any Third Party to access the Evaluation Board. As used herein, the term "Third Party" includes any entity other than ADI, Customer, their employees, affiliates and in-house consultants. The Evaluation Board is NOT sold to Customer; all rights not expressly granted herein, including ownership of the Evaluation Board, are reserved by ADI. CONFIDENTIALITY. This Agreement and the Evaluation Board shall all be considered the confidential and proprietary information of ADI. Customer may not disclose or transfer any portion of the Evaluation Board to any other party for any reason. Upon discontinuation of use of the Evaluation Board or termination of this Agreement, Customer agrees to promptly return the Evaluation Board to ADI. ADDITIONAL RESTRICTIONS. Customer may not disassemble, decompile or reverse engineer chips on the Evaluation Board. Customer shall inform ADI of any occurred damages or any modifications or alterations it makes to the Evaluation Board, including but not limited to soldering or any other activity that affects the material content of the Evaluation Board. Modifications to the Evaluation Board must comply with applicable law, including but not limited to the RoHS Directive. TERMINATION. ADI may terminate this Agreement at any time upon giving written notice to Customer. Customer agrees to return to ADI the Evaluation Board at that time. LIMITATION OF LIABILITY. THE EVALUATION BOARD PROVIDED HEREUNDER IS PROVIDED "AS IS" AND ADI MAKES NO WARRANTIES OR REPRESENTATIONS OF ANY KIND WITH RESPECT TO IT. ADI SPECIFICALLY DISCLAIMS ANY REPRESENTATIONS, ENDORSEMENTS, GUARANTEES, OR WARRANTIES, EXPRESS OR IMPLIED, RELATED TO THE EVALUATION BOARD INCLUDING, BUT NOT LIMITED TO, THE IMPLIED WARRANTY OF MERCHANTABILITY, TITLE, FITNESS FOR A PARTICULAR PURPOSE OR NON-INFRINGEMENT OF INTELLECTUAL PROPERTY RIGHTS. IN NO EVENT WILL ADI AND ITS LICENSORS BE LIABLE FOR ANY INCIDENTAL, SPECIAL, INDIRECT OR CONSEQUENTIAL DAMAGES RESULTING FROM CUSTOMER'S POSSESSION OR USE OF THE EVALUATION BOARD, INCLUDING BUT NOT LIMITED TO LOST PROFITS, DELAY COSTS, LABOR COSTS OR LOSS OF GOODWILL. ADI'S TOTAL LIABILITY FROM ANY AND ALL CAUSES SHALL BE LIMITED TO THE AMOUNT OF ONE HUNDRED US DOLLARS (\$100.00). EXPORT. Customer agrees that it will not directly or indirectly export the Evaluation Board to another country, and that it will comply with all applicable United States federal laws and regulations relating to exports. GOVERNING LAW. This Agreement shall be governed by and construed in accordance with the substantive laws of the Commonwealth of Massachusetts (excluding conflict of law rules). Any legal action regarding this Agreement will be heard in the state or federal courts having jurisdiction in Suffolk County, Massachusetts, and Customer hereby submits to the personal jurisdiction and venue of such courts. The United Nations Convention on Contracts for the International Sale of Goods shall not apply to this Agreement and is expressly disclaimed.