

CUSTOMER DRAWING		SCALE N.T.S.		SHEET 1 OF 1		REV A1	
MATERIAL		FINISH		WEIGHT		SIZE	
DIMENSIONS: INCHES		TOLERANCES UNLESS OTHERWISE SPECIFIED:		APPLICATOR		RESTRICTED TO	
0 PLC ±		0.005		P. BECKER		A2 00779	
1 PLC ±		0.010		P. BECKER		DRAWING NO. 2181198	
2 PLC ±		0.015		E.C. CLAYBAUGH		DWN 16/JUN/11	
3 PLC ±		0.020		CHK 13/JUL/11		NAME	
4 PLC ±		0.030		P. BECKER		TE Connectivity	

TE P/N	"L" [INCHES]		OBSOLETE
	TOLERANCES	"L"	
2181198-1	±.48	2.0 FT	OBSOLETE
2181198-2	±.96	4.0 FT	
2181198-3	±1.44	6.0 FT	
2181198-4	±1.92	8.0 FT	OBSOLETE
2181198-5	±2.4	10.0 FT	
2181198-6	±2.88	12.0 FT	
2181198-7	±3.36	14.0 FT	
2181198-8	±3.84	16.0 FT	

- 3 WIRING SCHEDULE AS SHOWN
1. PACKAGING ACC. TO TE SPEC.107-18032 BUNDLE EVERY 25 ASSEMBLIES WITH A RUBBER BAND
 2. ELECTRICAL TEST CONTAINING "SHORT CIRCUIT TEST, CONTINUITY AND ACCURATE CAVITY ASSIGNMENT TEST" ACC. TO TE-SPEC.108-18857, SUBSECTION 3.1.1

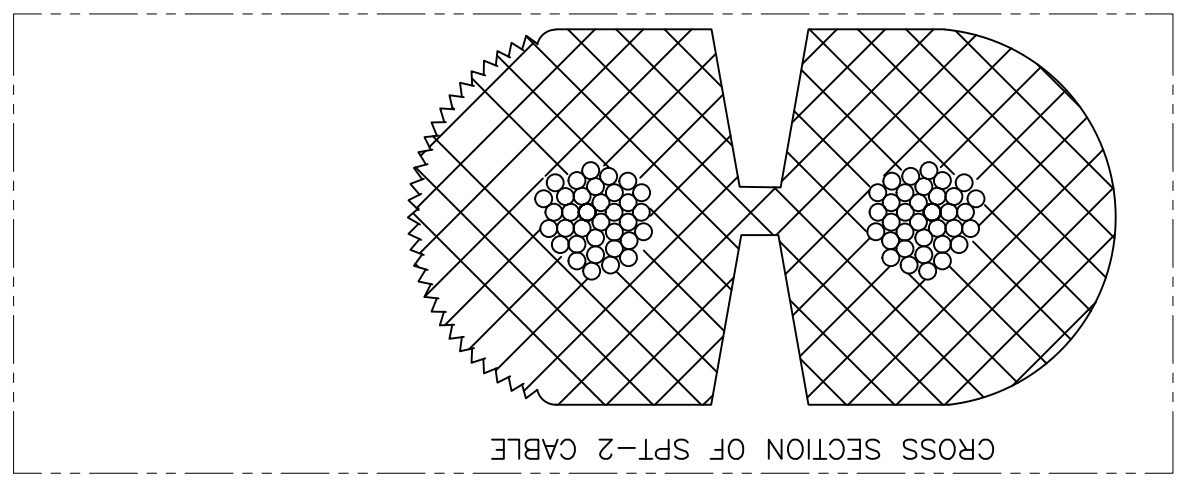

WIRING SCHEDULE		
OUTLET SIDE		2
RIBBED	+	1
SMOOTH	-	2

2181198

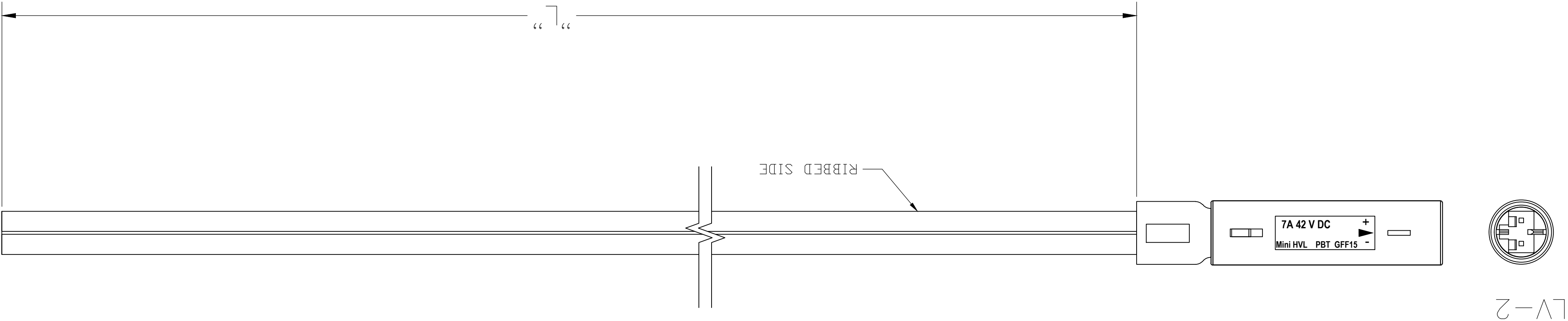

REVISIONS			
P	DATE	DESCRIPTION	APVD
A1	29SEP2020	ECR-20-004655	RK SBH