

Wide Input Range, High Efficiency, Step-Down Switching Regulator

FEATURES

- **Wide Input Range: 7.4V to 60V**
- 700mA Peak Switch Current Rating
- **Adaptive Switch Drive Maintains Efficiency at High Load Without Pulse Skipping at Light Load**
- True Current Mode Control
- 100kHz Fixed Operating Frequency
- Synchronizable to 250kHz
- Low Supply Current in Shutdown: 30 μ A
- Available in 8-Pin SO and PDIP Packages

APPLICATIONS

- Automotive DC/DC Converters
- Telecom 48V Step-Down Converters
- Cellular Phone Battery Charger Accessories
- IEEE 1394 Step-Down Converters

DESCRIPTION

The LT[®]1676 is a wide input range, high efficiency Buck (step-down) switching regulator. The monolithic die includes all oscillator, control and protection circuitry. The part can accept input voltages as high as 60V and contains an output switch rated at 700mA peak current. Current mode control offers excellent dynamic input supply rejection and short-circuit protection.

The LT1676 contains several features to enhance efficiency. The internal control circuitry is normally powered via the V_{CC} pin, thereby minimizing power drawn directly from the V_{IN} supply (see Applications Information). The action of the LT1676 switch circuitry is also load dependent. At medium to high loads, the output switch circuitry maintains high rise time for good efficiency. At light loads, rise time is deliberately reduced to avoid pulse skipping behavior.

The available SO-8 package and 100kHz switching frequency allow for minimal PC board area requirements.

LT, LTC and LT are registered trademarks of Linear Technology Corporation.

TYPICAL APPLICATION

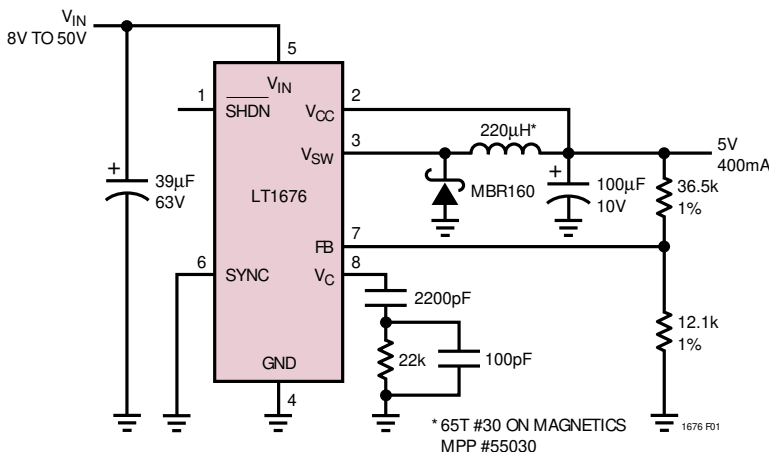
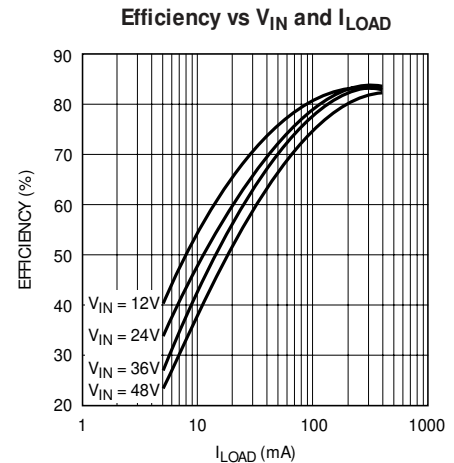

Figure 1



1676 TA01

ABSOLUTE MAXIMUM RATINGS

(Note 1)

| | |
|---|----------------|
| Supply Voltage | 60V |
| Switch Voltage | 60V |
| SHDN, SYNC Pin Voltage..... | 7V |
| V _{CC} Pin Voltage | 30V |
| FB Pin Voltage | 3V |
| Operating Junction Temperature Range | |
| LT1676C..... | 0°C to 125°C |
| LT1676I | -40°C to 125°C |
| Storage Temperature Range | -65°C to 150°C |
| Lead Temperature (Soldering, 10 sec)..... | 300°C |

PACKAGE/ORDER INFORMATION

| | |
|---|--|
| <p>TOP VIEW</p> <p>N8 PACKAGE: 8-LEAD PDIP S8 PACKAGE: 8-LEAD PLASTIC SO</p> <p>T_{JMAX} = 125°C, θ_{JA} = 130°C/W (N8) T_{JMAX} = 125°C, θ_{JA} = 110°C/W (S8)</p> | ORDER PART NUMBER |
| | LT1676CN8 LT1676CS8 LT1676IN8 LT1676IS8 |
| | S8 PART MARKING |
| | 1676 1676I |

Consult factory for Military grade parts.

ELECTRICAL CHARACTERISTICS

The ● denotes specifications which apply over the full operating temperature range, otherwise specifications are T_A = 25°C.

V_{IN} = 48V, V_{SW} open, V_{CC} = 5V, V_C = 1.4V unless otherwise noted.

| SYMBOL | PARAMETER | CONDITIONS | MIN | TYP | MAX | UNITS |
|-------------------------------------|--|-----------------------------|-----|----------------|----------------|--------------|
| Power Supplies | | | | | | |
| V _{IN(MIN)} | Minimum Input Voltage | | ● | 6.7 | 7.0 7.4 | V V |
| I _{VIN} | V _{IN} Supply Current | V _C = 0V | ● | 620 | 800 900 | μA μA |
| I _{VCC} | V _{CC} Supply Current | V _C = 0V | ● | 3.2 | 4.0 5.0 | mA mA |
| V _{VCC} | V _{CC} Dropout Voltage | (Note 2) | ● | 2.8 | 3.1 | V |
| | Shutdown Mode I _{VIN} | V _{SHDN} = 0V | ● | 30 | 50 75 | μA μA |
| Feedback Amplifier | | | | | | |
| V _{REF} | Reference Voltage | | ● | 1.225 1.215 | 1.240 1.265 | V V |
| I _{IN} | FB Pin Input Bias Current | | | 600 | 1500 | nA |
| g _m | Feedback Amplifier Transconductance | ΔI _c = ±10μA | ● | 400 200 | 650 1500 | μmho μmho |
| I _{SRC} , I _{SNK} | Feedback Amplifier Source or Sink Current | | ● | 60 45 | 100 220 | μA μA |
| V _{CL} | Feedback Amplifier Clamp Voltage | | | 2.0 | | V |
| | Reference Voltage Line Regulation | 12V ≤ V _{IN} ≤ 60V | ● | | 0.01 | %/V |
| | Voltage Gain | | | 200 | 600 | V/V |
| Output Switch | | | | | | |
| V _{ON} | Output Switch On Voltage | I _{SW} = 0.5A | | 1.0 | 1.5 | V |
| I _{LIM} | Switch Current Limit | (Note 3) | ● | 0.55 | 0.70 1.0 | A |
| Current Amplifier | | | | | | |
| | Control Pin Threshold | Duty Cycle = 0% | | 0.9 | 1.1 1.25 | V |
| | Control Voltage to Switch Transconductance | | | 2 | | A/V |

ELECTRICAL CHARACTERISTICS

The ● denotes specifications which apply over the full operating temperature range, otherwise specifications are $T_A = 25^\circ\text{C}$.
 $V_{IN} = 48\text{V}$, V_{SW} open, $V_{CC} = 5\text{V}$, $V_C = 1.4\text{V}$ unless otherwise noted.

| SYMBOL | PARAMETER | CONDITIONS | MIN | TYP | MAX | UNITS |
|--------------------------|---------------------------|---|-------|-------|-----|---------------|
| Timing | | | | | | |
| f | Switching Frequency | | ● 90 | 100 | 110 | kHz |
| | | | ● 85 | | 115 | |
| | Maximum Switch Duty Cycle | | ● 85 | 90 | | % |
| $t_{ON(MIN)}$ | Minimum Switch On Time | High dV/dt Mode, $R_L = 50\Omega$ (Note 4) | | 300 | | ns |
| Boost Operation | | | | | | |
| | V_C Pin Boost Threshold | | | 1.35 | | V |
| | dV/dt Below Threshold | | | 0.2 | | V/ns |
| | dV/dt Above Threshold | | | 1.6 | | V/ns |
| Sync Function | | | | | | |
| | Minimum Sync Amplitude | | ● | 1.5 | 2.2 | V |
| | Synchronization Range | | ● 130 | | 250 | kHz |
| | SYNC Pin Input R | | | 40 | | k Ω |
| SHDN Pin Function | | | | | | |
| V_{SHDN} | Shutdown Mode Threshold | | ● 0.2 | 0.5 | 0.8 | V |
| | | | | | | V |
| | | | | 1.260 | | V |
| | Lower Lockout Threshold | Switching Action Off | | 1.245 | | V |
| I_{SHDN} | Shutdown Pin Current | $V_{SHDN} = 0\text{V}$ $V_{SHDN} = 1.25\text{V}$ | | 12 | 20 | μA |
| | | | | 2.5 | 10 | μA |

Note 1: Absolute Maximum Ratings are those values beyond which the life of a device may be impaired.

Note 2: Control circuitry powered from V_{CC} .

Note 3: Switch current limit is DC trimmed and tested in production. Inductor di/dt rate will cause a somewhat higher current limit in actual application.

Note 4: Minimum switch on time is production tested with a 50Ω resistive load to ground.

TYPICAL PERFORMANCE CHARACTERISTICS

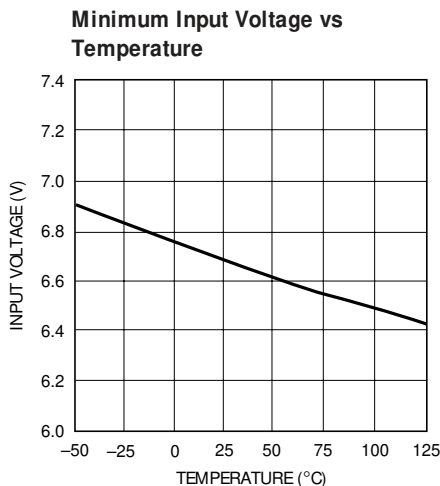

LT1676 G01

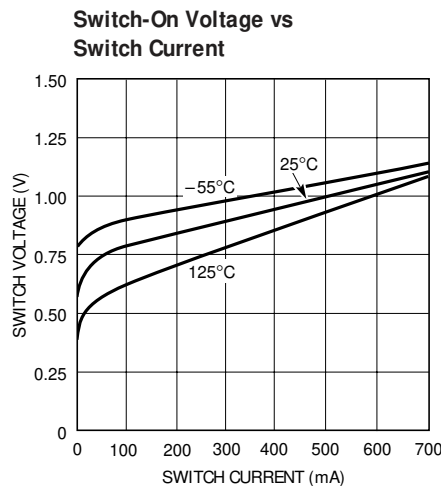

1676 G02

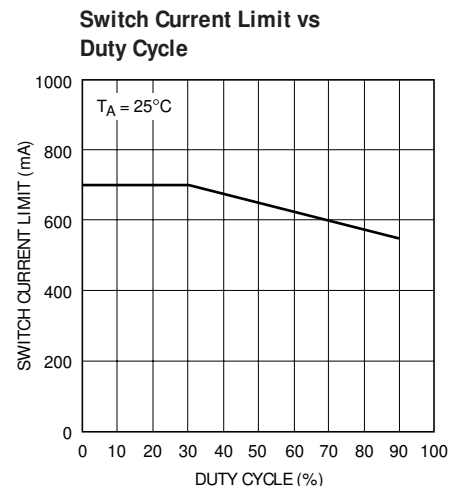

1676 G03

TYPICAL PERFORMANCE CHARACTERISTICS

SHDN Pin Shutdown Threshold vs Temperature

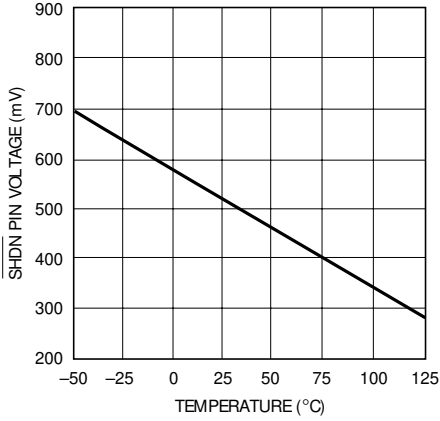

LT1676 G04

SHDN Pin Input Current vs Voltage

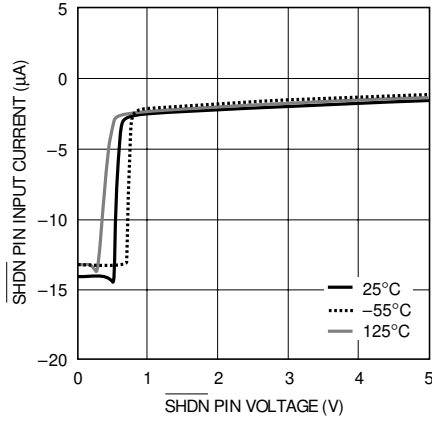

1676 G05

SHDN Pin Lockout Thresholds vs Temperature

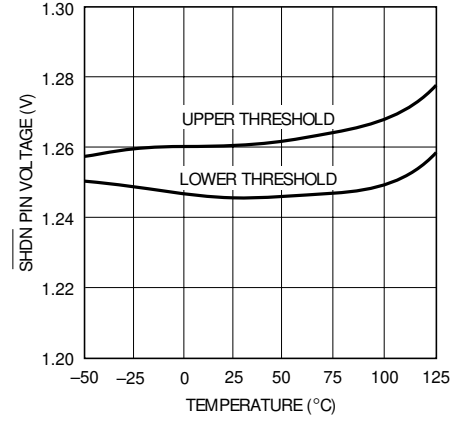

LT1676 G06

Switching Frequency vs Temperature

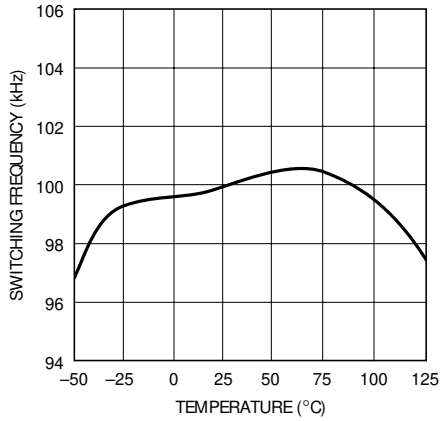

1676 G07

Minimum Synchronization Voltage vs Temperature

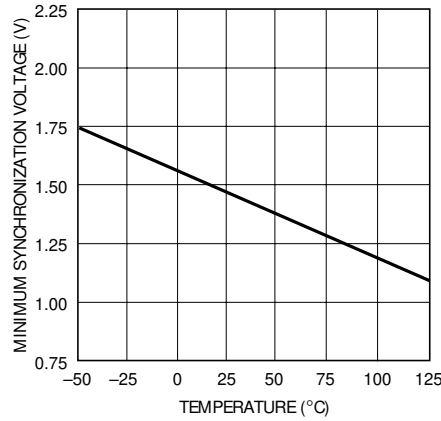

1676 G08

Switch Minimum On-Time vs Temperature

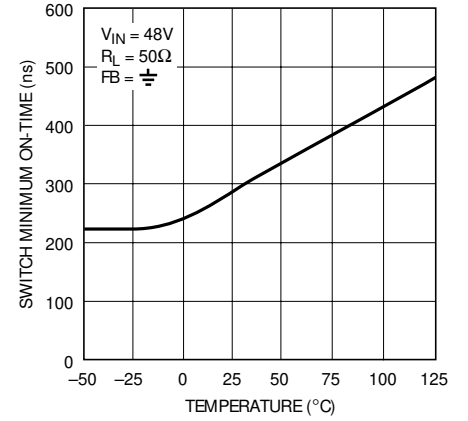

1676 G09

V_C Pin Switching Threshold, Boost Threshold, Clamp Voltage vs Temperature

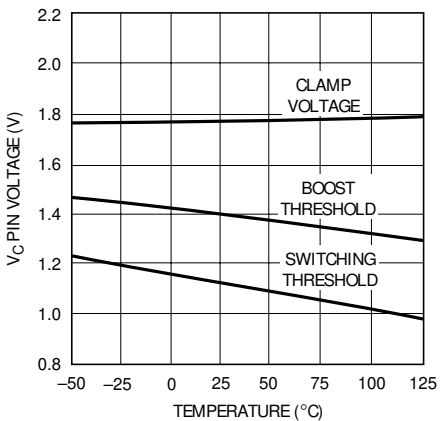

LT1676 G10

Feedback Amplifier Output Current vs FB Pin Voltage

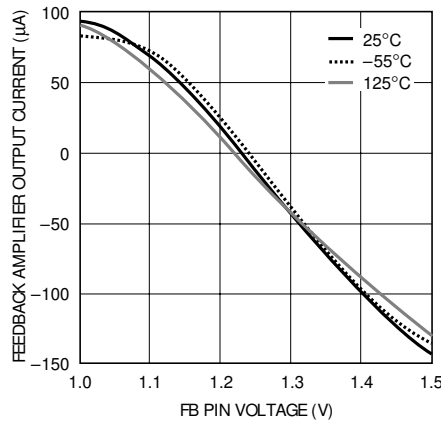

1676 G11

Error Amplifier Transconductance vs Temperature

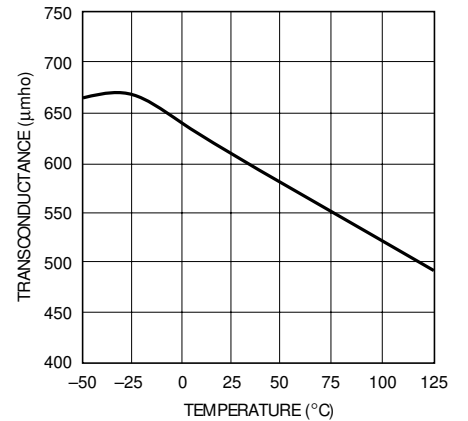

LT1676 G12

PIN FUNCTIONS

SHDN (Pin 1): When pulled below the shutdown mode threshold, nominally 0.30V, this pin turns off the regulator and reduces V_{IN} input current to a few tens of microamperes (shutdown mode).

When this pin is held above the shutdown mode threshold, but below the lockout threshold, the part will be operational with the exception that output switching action will be inhibited (lockout mode). A user-adjustable undervoltage lockout can be implemented by driving this pin from an external resistor divider to V_{IN} . This action is logically “ANDed” with the internal UVLO, set at nominally 6.7V, such that minimum V_{IN} can be increased above 6.7V, but not decreased (see Applications Information).

If unused, this pin should be left open. However, the high impedance nature of this pin renders it susceptible to coupling from the high speed V_{SW} node, so a small capacitor to ground, typically 100pF or so is recommended when the pin is left “open.”

V_{CC} (Pin 2): This pin is used to power the internal control circuitry off of the switching supply output. Proper use of this pin enhances overall power supply efficiency. During start-up conditions, internal control circuitry is powered directly from V_{IN} . If the output capacitor is located more than an inch from the V_{CC} pin, a separate 0.1 μ F bypass capacitor to ground may be required right at the pin.

V_{SW} (Pin 3): This is the emitter node of the output switch and has large currents flowing through it. This node moves at a high dV/dt rate, especially when in “boost” mode. Keep the traces to the switching components as

short as possible to minimize electromagnetic radiation and voltage spikes.

GND (Pin 4): This is the device ground pin. The internal reference and feedback amplifier are referred to it. Keep the ground path connection to the FB divider and the V_C compensation capacitor free of large ground currents.

V_{IN} (Pin 5): This is the high voltage supply pin for the output switch. It also supplies power to the internal control circuitry during start-up conditions or if the V_{CC} pin is left open. A high quality bypass capacitor that meets the input ripple current requirements is needed here. (See Applications Information.)

SYNC (Pin 6): Pin used to synchronize internal oscillator to the external frequency reference. It is directly logic compatible and can be driven with any signal between 10% and 90% duty cycle. The sync function is internally disabled if the FB pin voltage is low enough to cause oscillator slowdown. If unused, this pin should be grounded.

FB (Pin 7): This is the inverting input to the feedback amplifier. The noninverting input of this amplifier is internally tied to the 1.24V reference. This pin also slows down the frequency of the internal oscillator when its voltage is abnormally low, e.g., 2/3 of normal or less. This feature helps maintain proper short-circuit protection.

V_C (Pin 8): This is the control voltage pin which is the output of the feedback amplifier and the input of the current comparator. Frequency compensation of the overall loop is effected by placing a capacitor, (or in most cases a series RC combination) between this node and ground.

TIMING DIAGRAMS

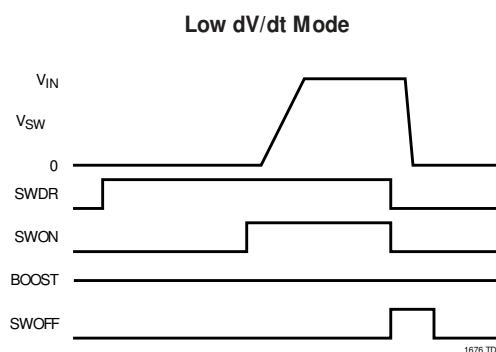
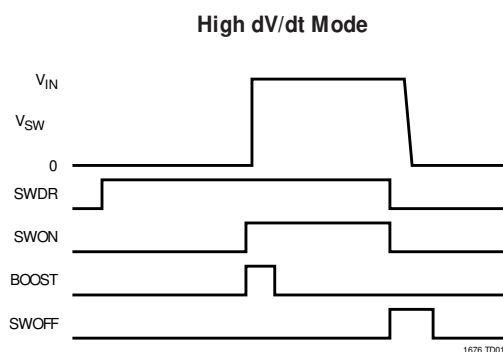

BLOCK DIAGRAM

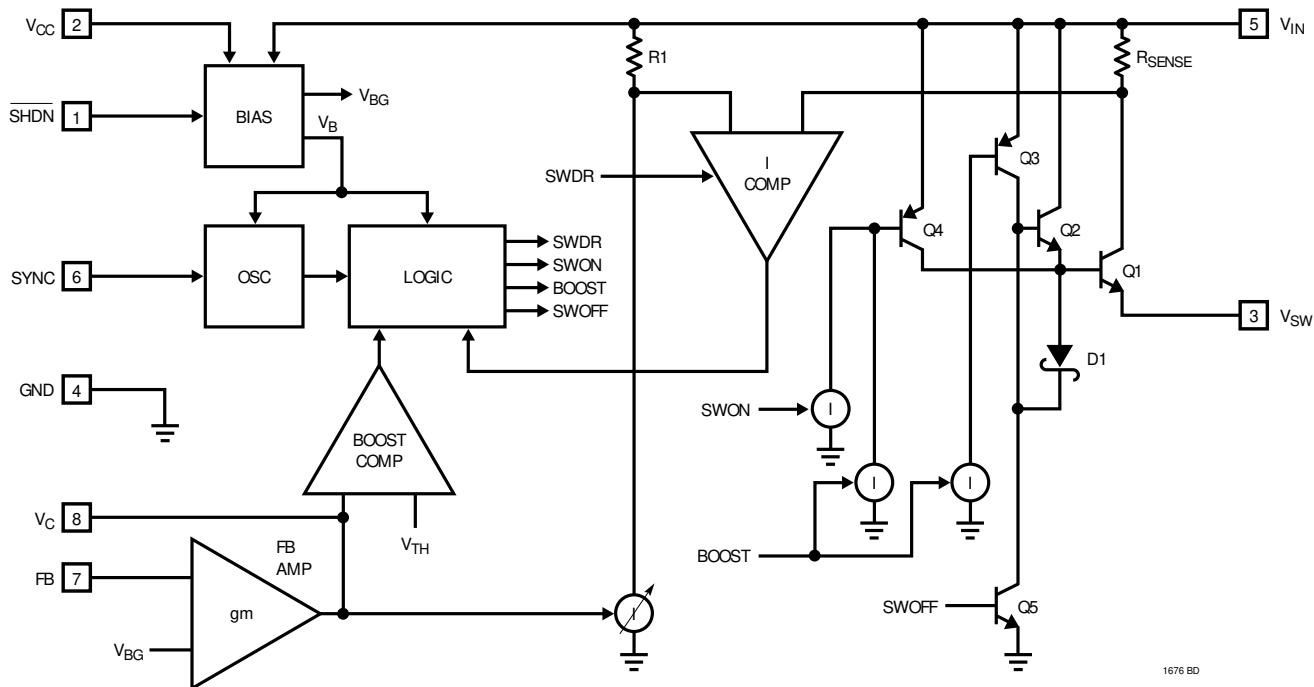

OPERATION

The LT1676 is a current mode switching regulator IC that has been optimized for high efficiency operation in high input voltage, low output voltage Buck topologies. The Block Diagram shows an overall view of the system. Several of the blocks are straightforward and similar to those found in traditional designs, including: Internal Bias Regulator, Oscillator and Feedback Amplifier. The novel portion includes an elaborate Output Switch section and Logic Section to provide the control signals required by the switch section.

The LT1676 operates much the same as traditional current mode switchers, the major difference being its specialized output switch section. Due to space constraints, this discussion will not reiterate the basics of current mode switcher/controllers and the “Buck” topology. A good source of information on these topics is Application Note 19.

Output Switch Theory

One of the classic problems in delivering low output voltage from high input voltage at good efficiency is that minimizing AC switching losses requires very fast voltage (dV/dt) and current (dI/dt) transition at the output device. This is in spite of the fact that in a bipolar implementation, slow lateral PNPs must be included in the switching signal path.

Fast positive-going slew rate action is provided by lateral PNP Q3 driving the Darlington arrangement of Q1 and Q2. The extra β available from Q2 greatly reduces the drive requirements of Q3.

Although desirable for dynamic reasons, this topology alone will yield a large DC forward voltage drop. A second lateral PNP, Q4, acts directly on the base of Q1 to reduce the voltage drop after the slewing phase has taken place. To achieve the desired high slew rate, PNPs Q3 and Q4 are “force-fed” packets of charge via the current sources controlled by the boost signal.

OPERATION

Please refer to the High dV/dt Mode Timing Diagram. A typical oscillator cycle is as follows: The logic section first generates an SWDR signal that powers up the current comparator and allows it time to settle. About 1μs later, the SWON signal is asserted and the BOOST signal is pulsed for a few hundred nanoseconds. After a short delay, the V_{SW} pin slews rapidly to V_{IN}. Later, after the peak switch current indicated by the control voltage V_C has been reached (current mode control), the SWON and SWDR signals are turned off, and SWOFF is pulsed for several hundred nanoseconds. The use of an explicit turn-off device, i.e., Q5, improves turn-off response time and thus aids both controllability and efficiency.

The system as previously described handles heavy loads (continuous mode) at good efficiency, but it is actually counterproductive for light loads. The method of jamming charge into the PNP bases makes it difficult to turn them off rapidly and achieve the very short switch ON times required by light loads in discontinuous mode. Furthermore, the high leading edge dV/dt rate similarly adversely affects light load controllability.

The solution is to employ a “boost comparator” whose inputs are the V_C control voltage and a fixed internal

threshold reference, V_{TH}. (Remember that in a current mode switching topology, the V_C voltage determines the peak switch current.) When the V_C signal is above V_{TH}, the previously described “high dV/dt” action is performed. When the V_C signal is below V_{TH}, the boost pulses are absent, as can be seen in the Low dV/dt Mode Timing Diagram. Now the DC current, activated by the SWON signal alone, drives Q4 and this transistor drives Q1 by itself. The absence of a boost pulse, plus the lack of a second NPN driver, result in a much lower slew rate which aids light load controllability.

A further aid to overall efficiency is provided by the specialized bias regulator circuit, which has a pair of inputs, V_{IN} and V_{CC}. The V_{CC} pin is normally connected to the switching supply output. During start-up conditions, the LT1676 powers itself directly from V_{IN}. However, after the switching supply output voltage reaches about 2.9V, the bias regulator uses this supply as its input. Previous generation Buck controller ICs without this provision typically required hundreds of milliwatts of quiescent power when operating at high input voltage. This both degraded efficiency and limited available output current due to internal heating.

APPLICATIONS INFORMATION

Selecting a Power Inductor

There are several parameters to consider when selecting a power inductor. These include inductance value, peak current rating (to avoid core saturation), DC resistance, construction type, physical size, and of course, cost.

In a typical application, proper inductance value is dictated by matching the discontinuous/continuous crossover point with the LT1676 internal low-to-high dV/dt threshold. This is the best compromise between maintaining control with light loads while maintaining good efficiency with heavy loads. The fixed internal dV/dt threshold has a nominal value of 1.4V, which referred to the V_C pin threshold and control voltage to switch transconductance, corresponds to a peak current of about 200mA. Standard Buck converter theory yields the following expression for inductance at the discontinuous/continuous crossover:

$$L = \left(\frac{V_{OUT}}{f \cdot I_{PK}} \right) \left(\frac{V_{IN} - V_{OUT}}{V_{IN}} \right)$$

For example, substituting 48V, 5V, 200mA and 100kHz respectively for V_{IN}, V_{OUT}, I_{PK} and f yields a value of about 220μH. Note that the left half of this expression is independent of input voltage while the right half is only a weak function of V_{IN} when V_{IN} is much greater than V_{OUT}. This means that a single inductor value will work well over a range of “high” input voltage. And although a progressively smaller inductor is suggested as V_{IN} begins to approach V_{OUT}, note that the much higher ON duty cycles under these conditions are much more forgiving with respect to controllability and efficiency issues. Therefore when a wide input voltage range must be accommodated, say 10V to 50V for 5V_{OUT}, the user should choose an inductance value based on the maximum input voltage.

APPLICATIONS INFORMATION

Once the inductance value is decided, inductor peak current rating and resistance need to be considered. Here, the inductor peak current rating refers to the onset of saturation in the core material, although manufacturers sometimes specify a “peak current rating” which is derived from a worst-case combination of core saturation and self-heating effects. Inductor winding resistance alone limits the inductor’s current carrying capability as the I^2R power threatens to overheat the inductor. If applicable, remember to include the condition of output short circuit. Although the peak current rating of the inductor can be exceeded in short-circuit operation, as core saturation per se is not destructive to the core, excess resistive self-heating is still a potential problem.

The final inductor selection is generally based on cost, which usually translates into choosing the smallest physical size part that meets the desired inductance value, resistance and current carrying capability. An additional factor to consider is that of physical construction. Briefly stated, “open” inductors built on a rod- or barrel-shaped core generally offer the smallest physical size and lowest cost. However their open construction does not contain the resulting magnetic field, and they may not be acceptable in RFI-sensitive applications. Toroidal style inductors, many available in surface mount configuration, offer improved RFI performance, generally at an increase in cost and physical size. And although custom design is always a possibility, most potential LT1676 applications can be handled by the array of standard, off-the-shelf inductor products offered by the major suppliers.

Selecting Freewheeling Diode

Highest efficiency operation requires the use of a Schottky type diode. DC switching losses are minimized due to its low forward voltage drop, and AC behavior is benign due to its lack of a significant reverse recovery time. Schottky diodes are generally available with reverse voltage ratings of 60V and even 100V, and are price competitive with other types.

The use of so-called “ultrafast” recovery diodes is generally not recommended. When operating in continuous mode, the reverse recovery time exhibited by “ultrafast” diodes will result in a slingshot type effect. The power

internal switch will ramp up V_{IN} current into the diode in an attempt to get it to recover. Then, when the diode has finally turned off, some tens of nanoseconds later, the V_{SW} node voltage ramps up at an extremely high dV/dt , perhaps 5 to even 10V/ns! With real world lead inductances, the V_{SW} node can easily overshoot the V_{IN} rail. This can result in poor RFI behavior and if the overshoot is severe enough, damage the IC itself.

Selecting Bypass Capacitors

The basic topology as shown in Figure 1 uses two bypass capacitors, one for the V_{IN} input supply and one for the V_{OUT} output supply.

User selection of an appropriate output capacitor is relatively easy, as this capacitor sees only the AC ripple current in the inductor. As the LT1676 is designed for Buck or step-down applications, output voltage will nearly always be compatible with tantalum type capacitors, which are generally available in ratings up to 35V or so. These tantalum types offer good volumetric efficiency and many are available with specified ESR performance. The product of inductor AC ripple current and output capacitor ESR will manifest itself as peak-to-peak voltage ripple on the output node. (Note: If this ripple becomes too large, heavier control loop compensation, at least at the switching frequency, may be required on the V_C pin.) The most demanding applications, requiring very low output ripple, may be best served not with a single extremely large output capacitor, but instead by the common technique of a separate L/C lowpass post filter in series with the output. (In this case, “Two caps are better than one.”)

The input bypass capacitor is normally a more difficult choice. In a typical application e.g., $48V_{IN}$ to $5V_{OUT}$, relatively heavy V_{IN} current is drawn by the power switch for only a small portion of the oscillator period (low ON duty cycle). The resulting RMS ripple current, for which the capacitor must be rated, is often several times the DC average V_{IN} current. Similarly, the “glitch” seen on the V_{IN} supply as the power switch turns on and off will be related to the product of capacitor ESR, and the relatively high instantaneous current drawn by the switch. To compound these problems is the fact that most of these applications will be designed for a relatively high input voltage, for

APPLICATIONS INFORMATION

which tantalum capacitors are generally unavailable. Relatively bulky “high frequency” aluminum electrolytic types, specifically constructed and rated for switching supply applications, may be the only choice.

Minimum Load Considerations

As discussed previously, a lightly loaded LT1676 with V_C pin control voltage below the boost threshold will operate in low dV/dt mode. This affords greater controllability at light loads, as minimum t_{ON} requirements are relaxed. In many applications, it is possible to operate the LT1676 down to zero external load without “pulse skipping”! In these cases, the LT1676’s modest V_{CC} current requirement of several milliamperes provides enough of a load to avoid pulse skipping.

However, some users may be indifferent to pulse skipping behavior, but instead may be concerned with maintaining maximum possible efficiency at light loads. This requirement can be satisfied by forcing the part into Burst Mode™ operation. The use of an external comparator whose output controls the shutdown pin allows high efficiency at light loads through Burst Mode operation behavior (see Typical Applications and Figure 8).

Maximum Load/Short-Circuit Considerations

The LT1676 is a current mode controller. It uses the V_C node voltage as an input to a current comparator which turns off the output switch on a cycle-by-cycle basis as this peak current is reached. The internal clamp on the V_C node, nominally 2V, then acts as an output switch peak current limit. This action becomes the switch current limit specification. The maximum available output power is then determined by the switch current limit.

A potential controllability problem could occur under short-circuit conditions. If the power supply output is short circuited, the feedback amplifier responds to the low output voltage by raising the control voltage, V_C , to its peak current limit value. Ideally, the output switch would be turned on, and then turned off as its current exceeded the value indicated by V_C . However, there is finite response time involved in both the current comparator and turnoff of the output switch. These result in a minimum on time

$t_{ON(MIN)}$. When combined with the large ratio of V_{IN} to $(V_F + I \cdot R)$, the diode forward voltage plus inductor $I \cdot R$ voltage drop, the potential exists for a loss of control. Expressed mathematically the requirement to maintain control is:

$$f \cdot t_{ON} \leq \frac{V_F + I \cdot R}{V_{IN}}$$

where:

f = switching frequency

t_{ON} = switch ON time

V_F = diode forward voltage

V_{IN} = Input voltage

$I \cdot R$ = inductor $I \cdot R$ voltage drop

If this condition is not observed, the current will not be limited at I_{PK} , but will cycle-by-cycle ratchet up to some higher value. Using the nominal LT1676 clock frequency of 100KHz, a V_{IN} of 48V and a $(V_F + I \cdot R)$ of say 0.7V, the maximum t_{ON} to maintain control would be approximately 140ns, an unacceptably short time.

The solution to this dilemma is to slow down the oscillator when the FB pin voltage is abnormally low thereby indicating some sort of short-circuit condition. Figure 2 shows the typical response of Oscillator Frequency vs FB divider Thevenin voltage and impedance. Oscillator frequency is unaffected until FB voltage drops to about 2/3 of its normal value. Below this point the oscillator frequency decreases roughly linearly down to a limit of about 25kHz. This lower

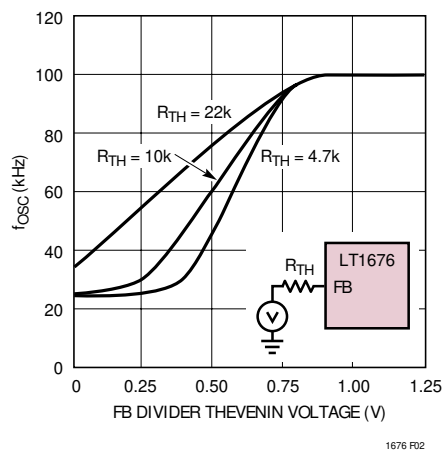

Figure 2. Oscillator Frequency vs FB Divider Thevenin Voltage and Impedance

Burst Mode is a trademark of Linear Technology Corporation.

APPLICATIONS INFORMATION

oscillator frequency during short-circuit conditions can then maintain control with the effective minimum ON time.

A further potential problem with short-circuit operation might occur if the user were operating the part with its oscillator slaved to an external frequency source via the SYNC pin. However, the LT1676 has circuitry that automatically disables the sync function when the oscillator is slowed down due to abnormally low FB voltage.

Feedback Divider Considerations

An LT1676 application typically includes a resistive divider between V_{OUT} and ground, the center node of which drives the FB pin to the reference voltage V_{REF} . This establishes a fixed ratio between the two resistors, but a second degree of freedom is offered by the overall impedance level of the resistor pair. The most obvious effect this has is one of efficiency—a higher resistance feedback divider will waste less power and offer somewhat higher efficiency, especially at light load.

However, remember that oscillator slowdown to achieve short-circuit protection (discussed above) is dependent on FB pin behavior, and this in turn, is sensitive to FB node external impedance. Figure 2 shows the typical relationship between FB divider Thevenin voltage and impedance, and oscillator frequency. This shows that as feedback network impedance increases beyond 10k, complete oscillator slowdown is not achieved, and short-circuit protection may be compromised. And as a practical matter, the product of FB pin bias current and larger FB network impedances will cause increasing output voltage error. (Nominal cancellation for 10k of FB Thevenin impedance is included internally.)

Thermal Considerations

Care should be taken to ensure that the worst-case input voltage and load current conditions do not cause excessive die temperatures. The packages are rated at 110°C/W for the 8-pin SO (S8) and 130°C/W for 8-pin PDIP (N8).

Quiescent power is given by:

$$P_Q = I_{VIN} \cdot V_{IN} + I_{VCC} \cdot V_{OUT}$$

(This assumes that the V_{CC} pin is connected to V_{OUT} .)

Power loss internal to the LT1676 related to actual output current is composed of both DC and AC switching losses. These can be roughly estimated as follows:

DC switching losses are dominated by output switch “ON voltage”, i.e.,

$$P_{DC} = V_{ON} \cdot I_{OUT} \cdot DC$$

V_{ON} = Output switch ON voltage, typically 1V at 500mA

I_{OUT} = Output current

DC = ON duty cycle

AC switching losses are typically dominated by power lost due to the finite rise time and fall time at the V_{SW} node. Assuming, for simplicity, a linear ramp up of both voltage and current and a current rise/fall time equal to 15ns,

$$P_{AC} = 1/2 \cdot V_{IN} \cdot I_{OUT} \cdot (t_r + t_f + 30ns) \cdot f$$

$t_r = (V_{IN}/1.6)$ ns in high dV/dt mode

$(V_{IN}/0.16)$ ns in low dV/dt mode

$t_f = (V_{IN}/1.6)$ ns (irrespective of dV/dt mode)

f = switching frequency

Total power dissipation of the die is simply the sum of quiescent, DC and AC losses previously calculated.

$$P_{D(TOTAL)} = P_Q + P_{DC} + P_{AC}$$

Frequency Compensation

Loop frequency compensation is performed by connecting a capacitor, or in most cases a series RC, from the output of the error amplifier (V_C pin) to ground. Proper loop compensation may be obtained by empirical methods as described in detail in Application Note 19. Briefly, this involves applying a load transient and observing the dynamic response over the expected range of V_{IN} and I_{LOAD} values.

As a practical matter, a second small capacitor, directly from the V_C pin to ground is generally recommended to attenuate capacitive coupling from the V_{SW} pin. A typical value for this capacitor is 100pF. (See Switch Node Considerations).

Switch Node Considerations

For maximum efficiency, switch rise and fall times are made as short as practical. To prevent radiation and high

APPLICATIONS INFORMATION

frequency resonance problems, proper layout of the components connected to the IC is essential, especially the power path. B field (magnetic) radiation is minimized by keeping output diode, switch pin and input bypass capacitor leads as short as possible. E field radiation is kept low by minimizing the length and area of all traces connected to the switch pin (V_{SW}). A ground plane should always be used under the switcher circuitry to prevent interplane coupling.

The high speed switching current path is shown schematically in Figure 3. Minimum lead length in these paths is essential to ensure clean switching and minimal EMI. The paths containing the input capacitor, output switch and output diode are the only ones containing nanosecond rise and fall times. Keep these paths as short as possible.

Additionally, it is possible for the LT1676 to cause EMI problems by “coupling to itself”. Specifically, this can occur if the V_{SW} pin is allowed to capacitively couple in an uncontrolled manner to the part’s high impedance nodes,

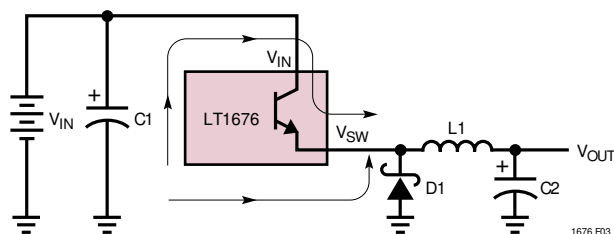

Figure 3. High Speed Current Switching Paths

i.e., \overline{SHDN} , \overline{SYNC} , V_C and \overline{FB} . This can cause erratic operation such as odd/even cycle behavior, pulse width “nervousness”, improper output voltage and/or premature current limit action.

As an example, assume that the capacitance between the V_{SW} node and a high impedance pin node is 0.1pF, and further assume that the high impedance node in question exhibits a capacitance of 1pF to ground. Due to the high dV/dt , large excursion behavior of the V_{SW} node, this will couple a nearly 5V transient to the high impedance pin, causing abnormal operation. (This assumes the “typical” 48V_{IN} to 5V_{OUT} application.) An explicit 100pF capacitor added to the node will reduce the amplitude of the disturbance to more like 50mV (although settling time will increase).

Specific pin recommendations are as follows:

\overline{SHDN} : If unused, add a 100pF capacitor to ground.

\overline{SYNC} : Ground if unused.

V_C : Add a capacitor directly to ground in addition to the explicit compensation network. A value of one-tenth of the main compensation capacitor is recommended, up to a maximum of 100pF.

\overline{FB} : Assuming the V_C pin is handled properly, this pin usually requires no explicit capacitor of its own, but keep this node physically small to minimize stray capacitance.

TYPICAL APPLICATIONS

Minimum Component Count Application

Figure 4a shows a basic “minimum component count” application. The circuit produces 5V at up to 500mA I_{OUT} with input voltages in the range of 12V to 48V. The typical P_{OUT}/P_{IN} efficiency is shown in Figure 4b. No pulse skipping is observed down to zero external load. As shown, the \overline{SHDN} and \overline{SYNC} pins are unused, however either (or both) can be optionally driven by external signals as desired.

User Programmable Undervoltage Lockout

Figure 5 adds a resistor divider to the basic application. This is a simple, cost-effective way to add a user-programmable undervoltage lockout (UVLO) function. Resistor R_5 is chosen to have approximately 200 μ A through it at the nominal \overline{SHDN} pin lockout threshold of roughly 1.25V. The somewhat arbitrary value of 200 μ A was chosen to be significantly above the \overline{SHDN} pin input current to minimize its error contribution, but significantly below the typical 3.2mA the LT1676 draws in lockout mode. Resistor R_4 is then chosen to yield this same 200 μ A, less 2.5 μ A, with the

TYPICAL APPLICATIONS

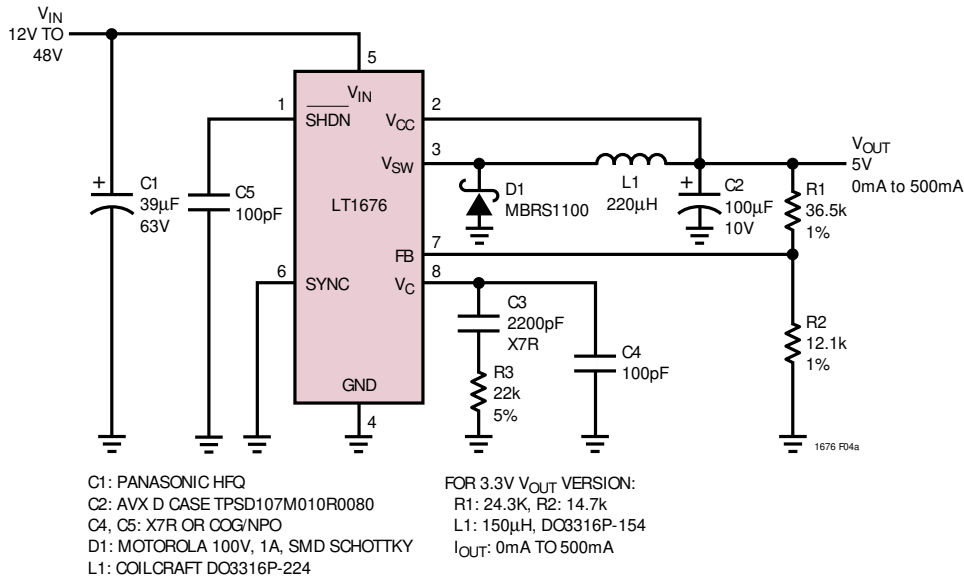

Figure 4a. Minimum Component Count Application

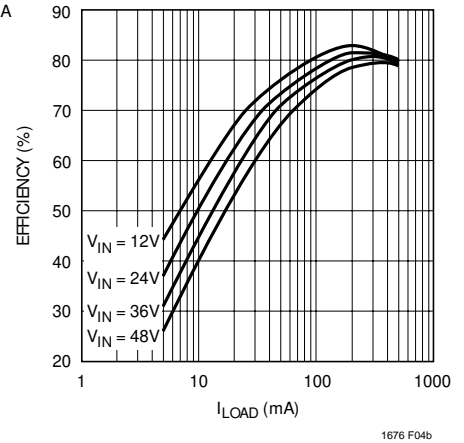

Figure 4b. P_{OUT}/P_{IN} Efficiency

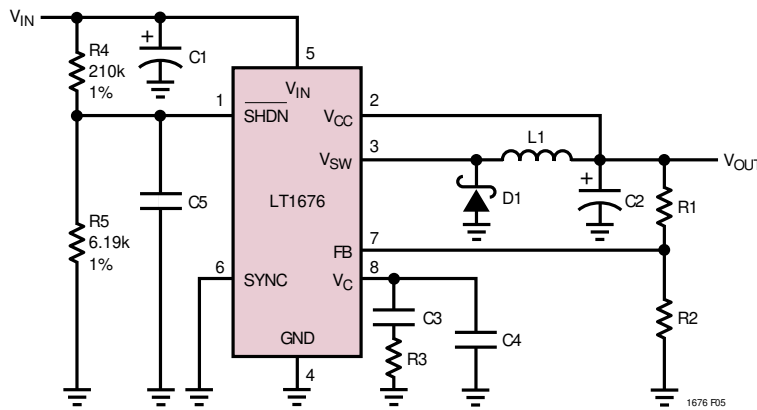

Figure 5. User Programmable Undervoltage Lockout

desired V_{IN} UVLO voltage minus 1.25V applied across it. (The 2.5µA factor is an allowance to minimize error due to SHDN pin input current.)

Behavior is as follows: Normal operation is observed at the nominal input voltage of 48V. As the input voltage is decreased to roughly 43V, switching action will stop, V_{OUT} will drop to zero, and the LT1676 will draw its V_{IN} and V_{CC} quiescent currents from the V_{IN} supply. At a much lower input voltage, typically 18V or so at 25°C, the voltage on

the SHDN pin will drop to the shutdown threshold, and the part will draw its shutdown current only from the V_{IN} rail. The resistive divider of R4 and R5 will continue to draw power from V_{IN} . (The user should be aware that while the SHDN pin *lockout* threshold is relatively accurate including temperature effects, the SHDN pin *shutdown* threshold is more coarse, and exhibits considerably more temperature drift. Nevertheless the shutdown threshold will always be well below the lockout threshold.)

TYPICAL APPLICATIONS

Micropower Undervoltage Lockout

Certain applications may require very low current drain when in undervoltage lockout mode. This can be accomplished with the addition of a few more external components. Figure 6 shows an LTC[®]1440 micropower comparator/reference added to control the LT1676 via its SHDN pin. The extremely low input bias current of the CMOS comparator allows the impedance of the resistor divider R4/R5 to be increased, thereby minimizing power drain. Hysteresis is externally programmable via resistor divider R6/R7. The LTC1440 output directly controls the LT1676 via its shutdown pin, driving it to either 5V (ON) or 0V (Full Shutdown). A simple linear voltage regulator to power the LTC1440 is provided by Q1, Q2 and R7. Just below the UVLO threshold, nominally 43V, total current drain is typically 50 μ A.

Burst Mode Operation Configuration

Figure 4b demonstrates that power supply efficiency degrades with lower output load current. This is not surprising, as the LT1676 itself represents a fixed power overhead.

A possible way to improve light load efficiency is in Burst Mode operation.

Figure 7 shows the LT1676 configured for Burst Mode operation. Output voltage regulation is now provided in a “bang-bang” digital manner, via comparator U2, an LTC1440. Resistor divider R3/R4 provides a scaled version of the output voltage, which is compared against U2’s internal reference. Intentional hysteresis is set by the R5/R6 divider. As the output voltage falls below the regulation range, the LT1676 is turned on. The output voltage rises, and as it climbs above the regulation range, the LT1676 is turned off. Efficiency is maximized, as the LT1676 is only powered up while it is providing heavy output current. Figure 7b shows that efficiency is typically maintained at 75% or better down to a load current of 10mA. Even at a load of 1mA, efficiency is still a respectable 59% to 68%, depending on V_{IN} .

Resistor divider R1/R2 is still present, but does not directly influence output voltage. It is chosen to ensure that the LT1676 delivers high output current throughout the voltage regulation range. Its presence is also required

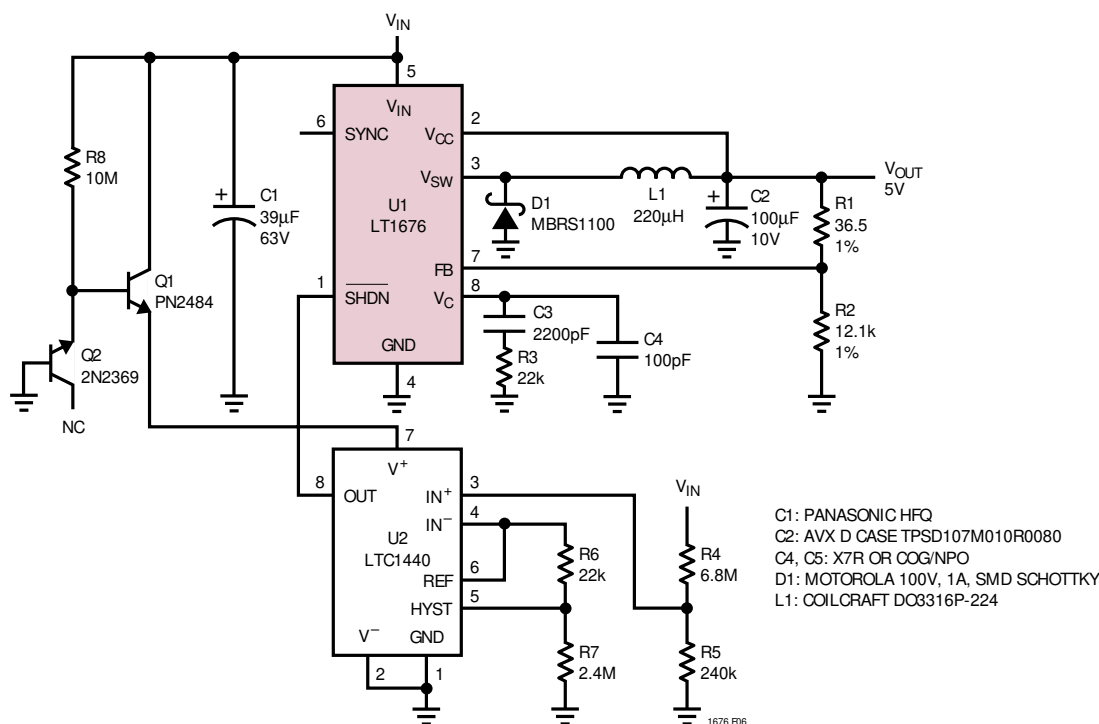

Figure 6. Micropower Undervoltage Lockout

TYPICAL APPLICATIONS

to maintain proper short-circuit protection. Transistors Q1, Q2 and resistor R7 form a high V_{IN} , low quiescent current voltage regulator to power U2.

Burst Mode Operation Configuration with UVLO

Figure 7a uses an external comparator to control the LT1676 via its SHDN pin. As such, the user's ability to set an undervoltage lockout (UVLO) threshold with a resistor divider from V_{IN} to SHDN pin to ground is lost. This ability is regained in the slightly more complicated circuit shown in Figure 8.

A dual comparator, the LTC1442, replaces the previous single comparator. The second comparator monitors a resistive divider between V_{IN} and ground to provide the (user-adjustable) UVLO function. The two comparator outputs are logically combined in a CMOS NOR gate (U3) to drive the LT1676 SHDN pin.

Minimum Size Inductor Application

Figure 4a employs power path parts that are capable of delivering the full rated output capability of the LT1676. Potential users with low output current requirements may be interested in substituting a physically smaller and less costly power inductor. The circuit shown on the last page of this data sheet is topologically identical to the basic application, but specifies a much smaller inductor, and, a somewhat smaller input electrolytic capacitor. This circuit is capable of delivering up to 150mA at 5V, or, up to 200mA at 3.3V. The only disadvantage is that due to the increased resistance in the inductor, the circuit is no longer capable of withstanding indefinite short circuits to ground. The LT1676 will still current limit at its nominal I_{LIM} value, but this will overheat the inductor. Momentary short circuits of a few seconds or less can still be tolerated.

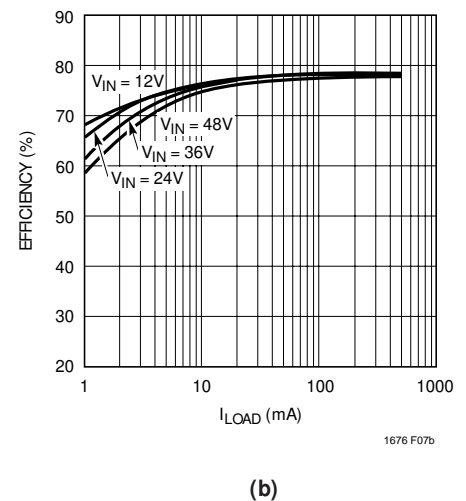
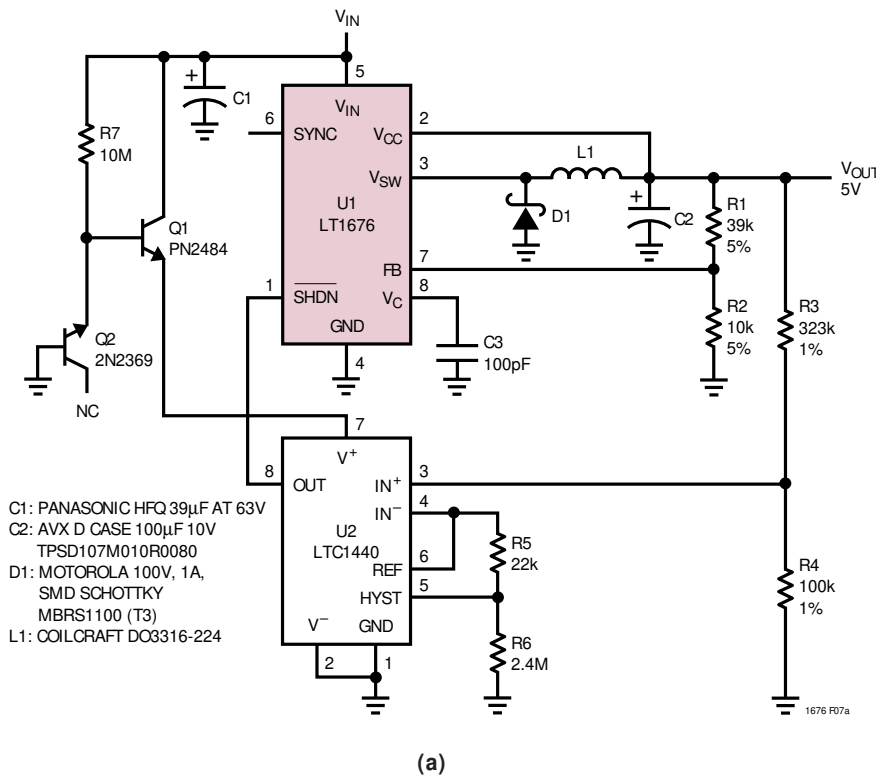

Figure 7. Burst Mode Operation Configuration for High Efficiency at Light Load

TYPICAL APPLICATIONS

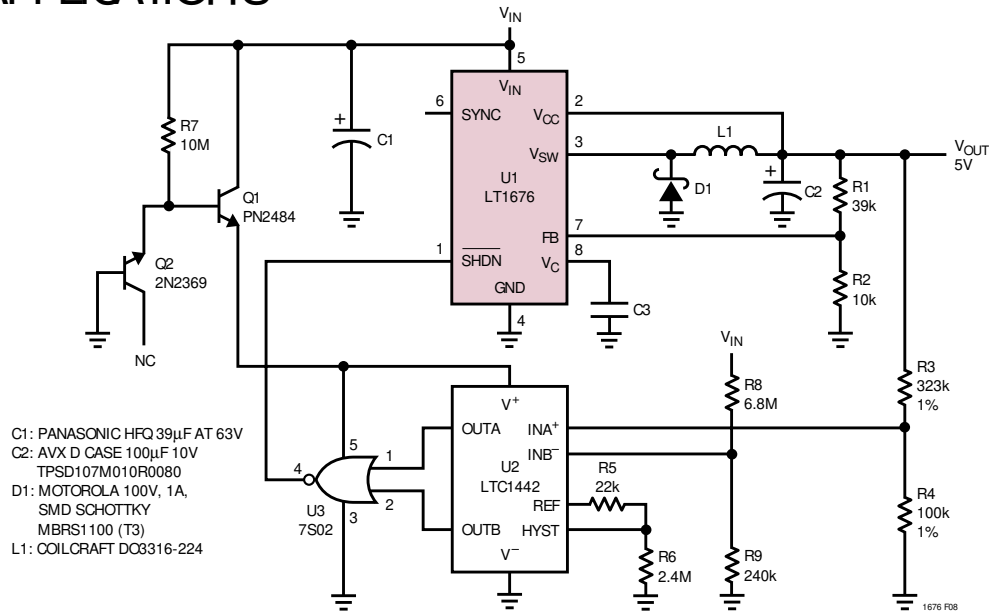
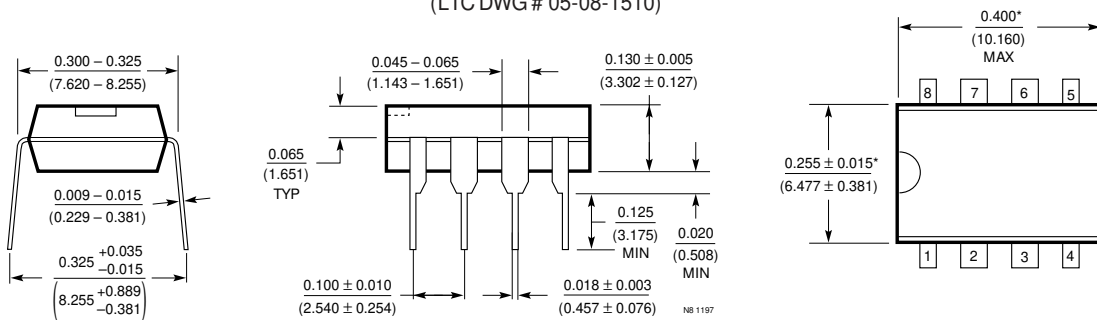

Figure 8. Burst Mode Operation Configuration with Micropower UVLO

PACKAGE DESCRIPTION

Dimensions in inches (millimeters) unless otherwise noted.

N8 Package
8-Lead PDIP (Narrow 0.300)
 (LTC DWG # 05-08-1510)



* THESE DIMENSIONS DO NOT INCLUDE MOLD FLASH OR PROTRUSIONS.
 MOLD FLASH OR PROTRUSIONS SHALL NOT EXCEED 0.010 INCH (0.254mm)

S8 Package
8-Lead Plastic Small Outline (Narrow 0.150)
 (LTC DWG # 05-08-1610)

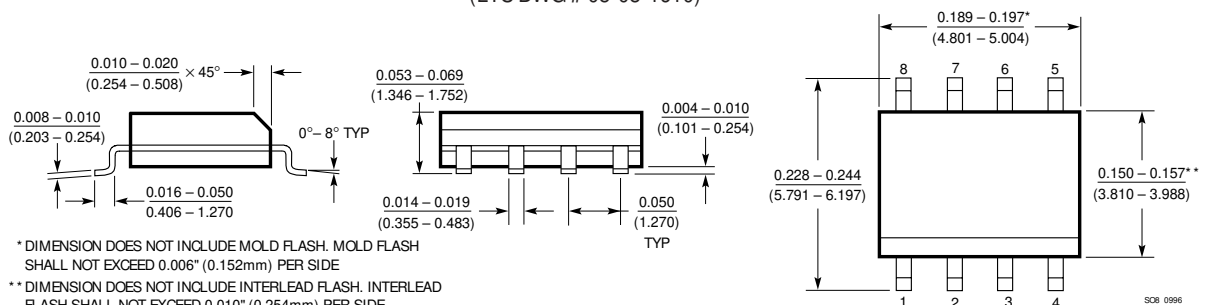

* DIMENSION DOES NOT INCLUDE MOLD FLASH. MOLD FLASH SHALL NOT EXCEED 0.006" (0.152mm) PER SIDE
 ** DIMENSION DOES NOT INCLUDE INTERLEAD FLASH. INTERLEAD FLASH SHALL NOT EXCEED 0.010" (0.254mm) PER SIDE

TYPICAL APPLICATION

Minimum Inductor Size Application

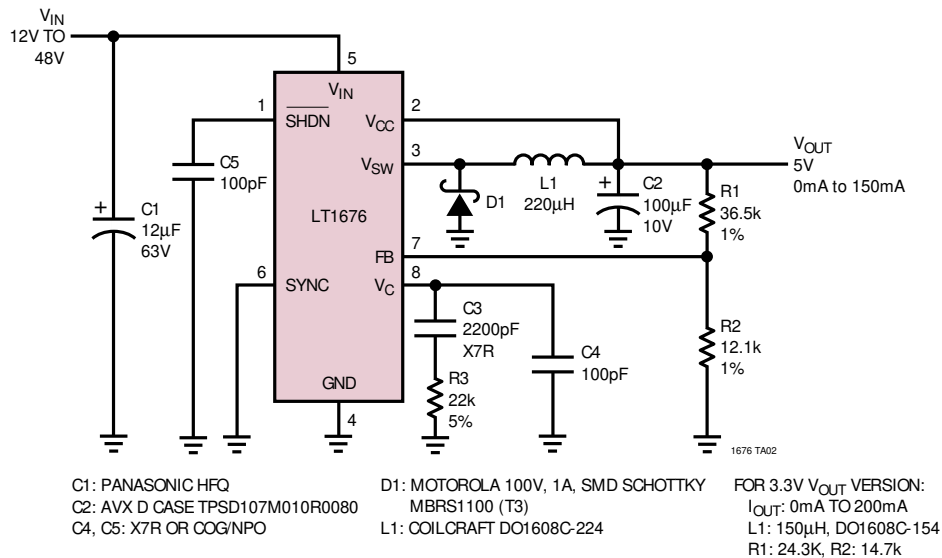

RELATED PARTS

| PART NUMBER | DESCRIPTION | COMMENTS |
|---------------|--|--|
| LT1076 | 2A, 100kHz Step-Down Switching Regulator | Operation Up to 45V Input (64V for HV Version) |
| LT1149 | High Efficiency Synchronous Step-Down Switching Regulator | Operation Up to 48V Input, 95% Efficiency, 100% Duty Cycle |
| LT1176 | 1.2A, 100kHz Step-Down Switching Regulator | Operation Up to 38V Input, Adjustable and Fixed 5V Versions |
| LT1339 | High Power Synchronous DC/DC Controller | Operation Up to 60V, High Power Anti-Shoot-Through Drivers |
| LT1375/LT1376 | 1.5A, 500kHz Step-Down Switching Regulators | Operation Up to 25V Input, Synchronizable (LT1375) |
| LT1620 | Rail-to-Rail Current Sense Amplifier | Transforms Switching Regulators Into High Efficiency Battery Chargers |
| LT1776 | Wide Input Range, High Efficiency, Step-Down Switching Regulator | LT1676 with 200kHz Switching Frequency (High Current Applications Generally Restricted to $\leq 40V$) |
| LT1777 | Low Noise Buck Regulator | Operation up to 48V, Controlled Voltage and Current Slew Rates |