

# GT25 Series

— SMT Multi-contact Connectors —

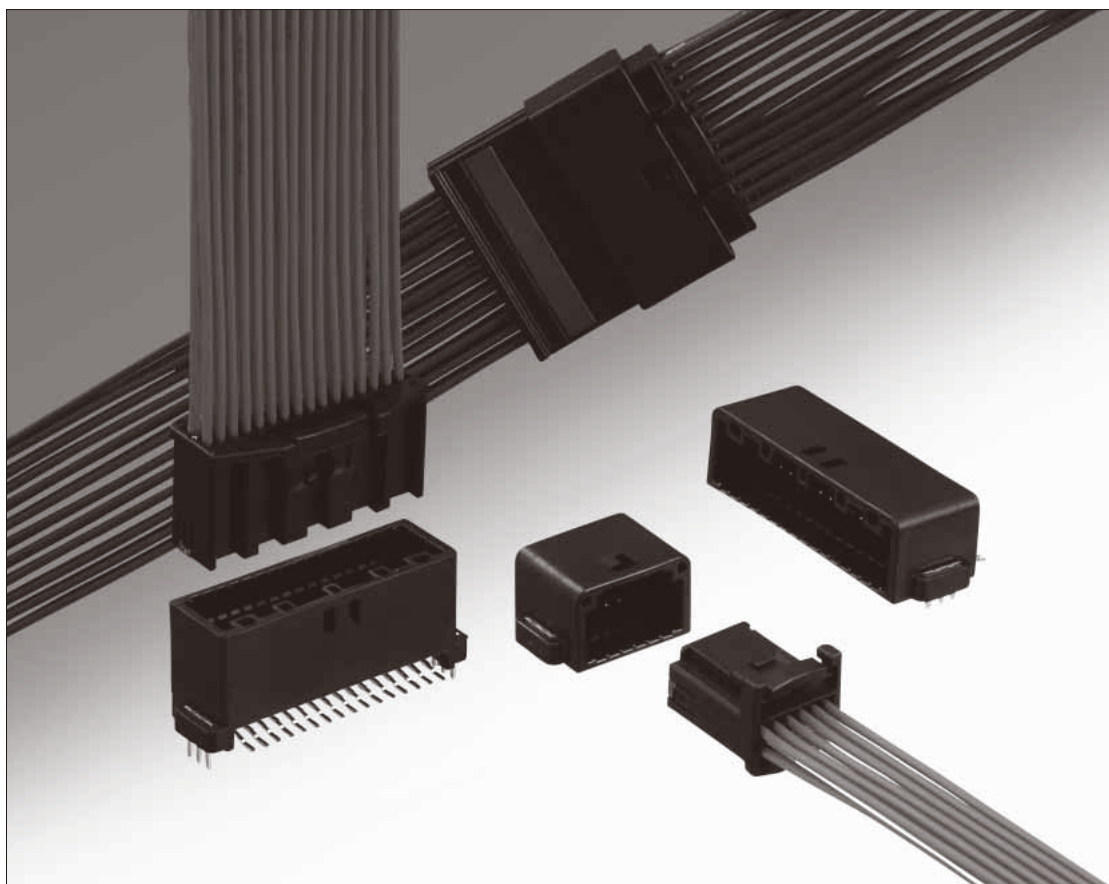

GT5

GT13

GT16

PO5G

GT19

GT21

GT26

GT36

GT11

GT17

GT32

GT3

GT7

GT10

GT18W

**GT25**

GT8E

GT9

GT15

Interface Connector

Sep.1.2018 Copyright 2018 HIROSE ELECTRIC CO., LTD. All Rights Reserved.

## ■ Features

- Metal holdowns to solder by reflow are used instead of screws for PCB mounting.
- The width of tab is 025 size.

## ■ Product Specifications

Rated Current	Insulation Resistance	Withstanding Voltage	Contact Resistance	Operating Temperature Range
3A (Note 1)	100MΩ min	AC650V for one minute	No more than 30mΩ (initially)	-40°C to +105°C (Note 2)

Note 1 : When using different conditions, please consult with Hirose.

Note 2 : Includes temperature rise caused by current flow.

Interface Connector  
Copyright 2018 HIROSE ELECTRIC CO., LTD. All Rights Reserved.

GT5

GT13

GT16

PO5G

GT19

GT21

GT26

GT36

GT11

GT17

GT32

GT3

GT7

GT10

GT18W

GT25

GT8E

GT9

GT15

## F Terminal

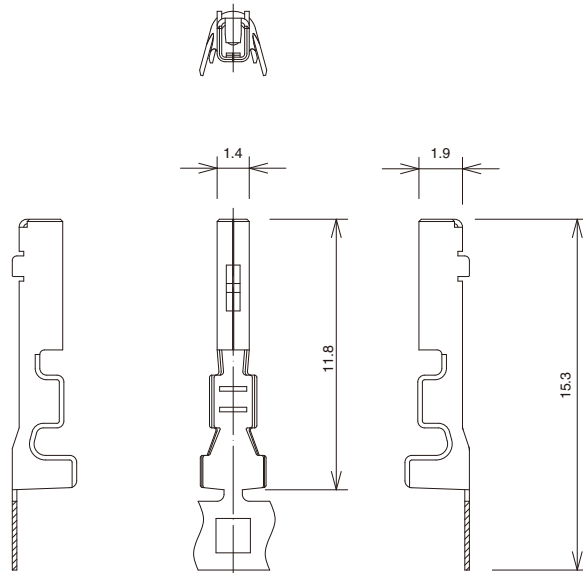
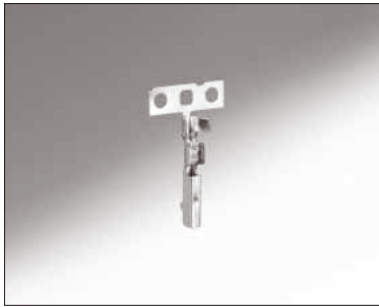

Part No.	HRS No.	Material	Plating	Conductor Size (AWG)	Outer Diameter	Packaging	RoHS
GT25H-2024SCF	775-0039-6	Copper palloy	Tin plating	20 to 22 AWG	φ 1.0 to 1.7	10,000 pcs/reel	YES
GT25HB-2428SCF	775-0070-6			24 to 28 AWG	φ 0.5 to 1.0		

## F Connector

### ● Housing (Pre-assembled retainer)

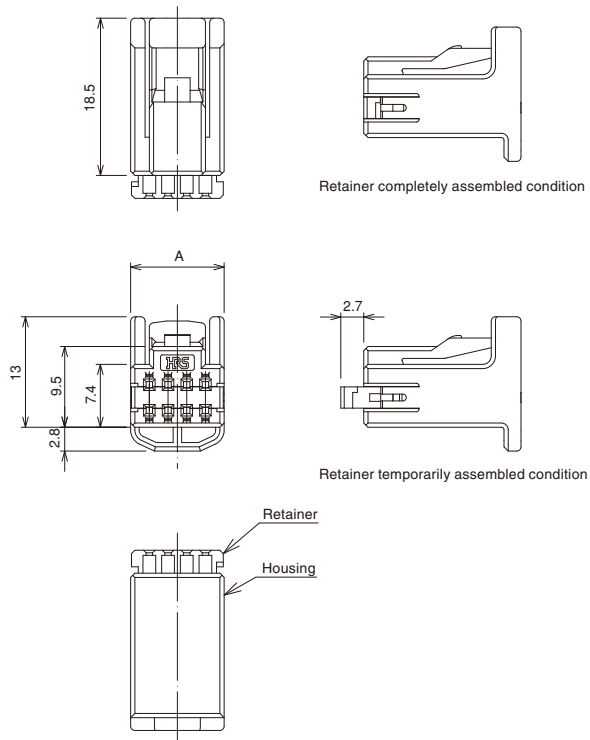
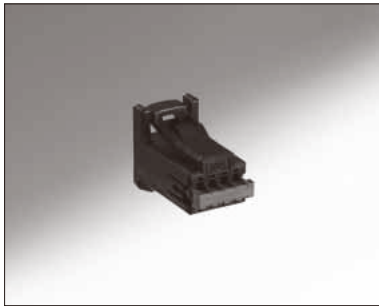

Part No.	HRS No.	Color	Material	No. of Contacts	A Dimension	Packaging	RoHS
GT25-8DS-HU/R	775-0059-3	Housing : Black Retainer : Dark Gray	Housing : PPE Retainer : PBT	8	11	1	YES
GT25-12DS-HU/R	775-0062-8		PBT	12	15.4		
GT25-24DS-HU/R	775-0046-1		Housing : PPE Retainer : PBT	24	28.6		
GT25-32DS-HU/R	775-0044-6		PBT	32	37.4		

Note 1 : Pre-assembled retainer into housing body

Note 2 : After insert assembled contact, retainer has to be pushed-in correct position

Note 3 : Available to purchase housing and retainer separately for repair.

**Improved prying force**

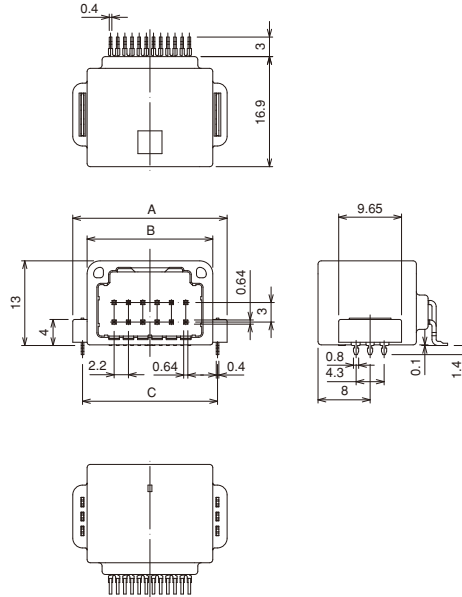

◆Recommended PCB pattern

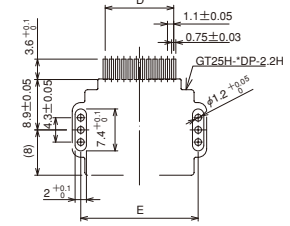

Part No.	HRS No.	Color	Material/ Plating	No. of Contacts	A Dimension	B Dimension	C Dimension	D Dimension	E Dimension	Packaging	RoHS
GT25H-12DP-2.2H	775-0038-3	Black	PPS Brass/ Tin plating	12	23.7	19.3	20.73	12.1±0.05	20.73±0.05	200 pcs/reel	YES
GT25H-20DP-2.2H	(Under development)			20	32.5	28.1	29.53	20.9±0.05	29.53±0.05		
GT25H-24DP-2.2H	775-0045-9			24	36.9	32.5	33.93	25.3±0.05	33.93±0.05		
GT25H-32DP-2.2H	(Under development)			32	45.7	41.3	42.73	34.1±0.05	42.73±0.05		

**Improved prying force**

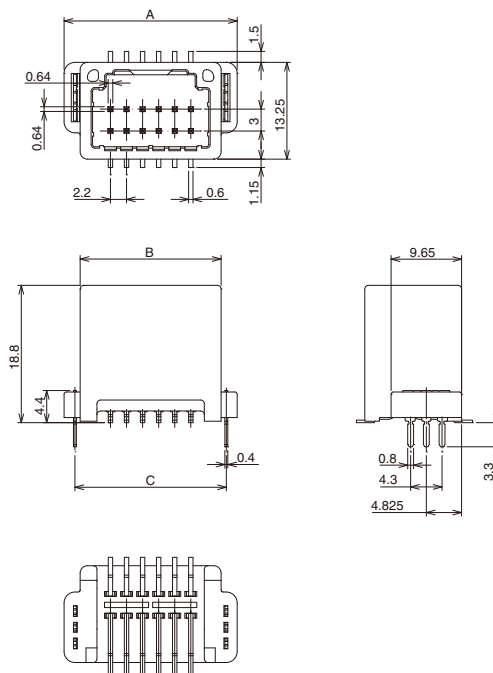
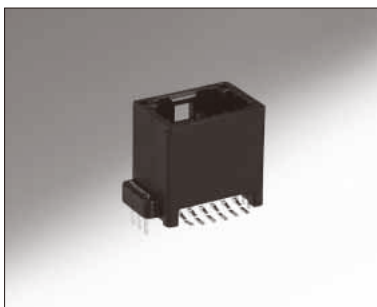

◆Recommended PCB pattern

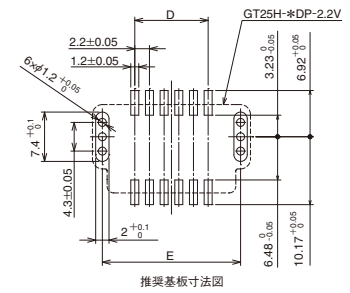

Part No.	HRS No.	Color	Material/ Plating	No. of Contacts	A Dimension	B Dimension	C Dimension	D Dimension	E Dimension	Packaging	RoHS
GT25H-12DP-2.2V	775-0050-9	Black	PPS Brass/ Tin plating	12	23.7	19.3	20.73	11±0.05	20.73±0.05	1	YES
GT25H-24DP-2.2V	(Under development)			24	36.9	32.5	33.93	24.2±0.05	33.93±0.05		
GT25H-32DP-2.2V	775-0053-7			32	45.7	41.3	42.73	33±0.05	42.73±0.05		



## M connector (PCB type)

### Straight Type

● 2 rows

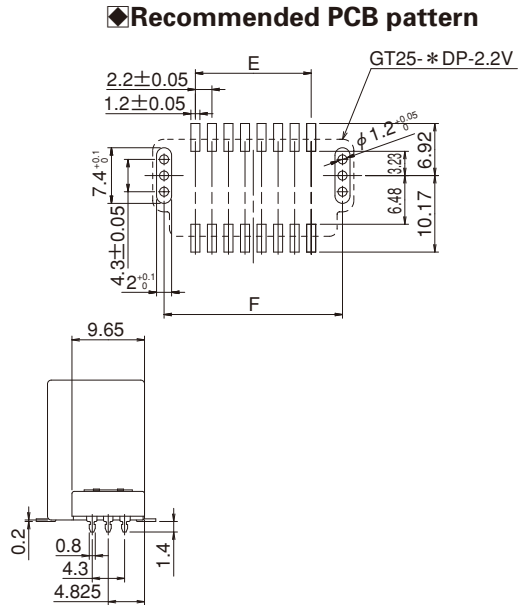
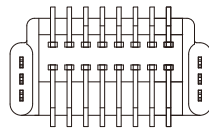
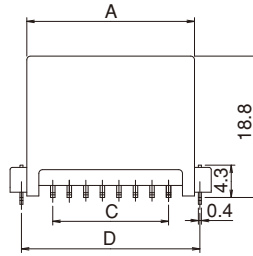
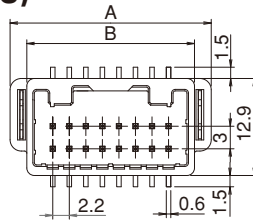
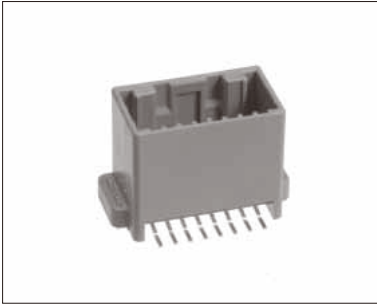

Part No.	HRS No.	Color	Material/ Plating	No. of Contacts	A Dimension	B Dimension	C Dimension	D Dimension	E Dimension	F Dimension	Packaging	RoHS
GT25-16DP-2.2V(01)	775-0020-8 01	Light Gray	PPS Brass/ Tin plating	16	26.75	22.3	15.4	23.73	15.4±0.05	23.73±0.05	1/tray	YES
GT25-24DP-2.2V(01)	775-0021-0 01			24	35.55	31.1	24.2	32.53	24.2±0.05	32.53±0.05		
GT25-32DP-2.2V(01)	775-0022-3 01			32	44.35	39.9	33.0	41.33	33±0.05	41.33±0.05		
GT25-40DP-2.2V(01)	775-0014-5 01			40	53.15	48.7	41.8	50.13	41.8±0.05	50.13±0.05		

### ◆ Crimping tools

User manuals are available. Please contact your Hirose Electric account representative.

● Automatic Crimping Machine

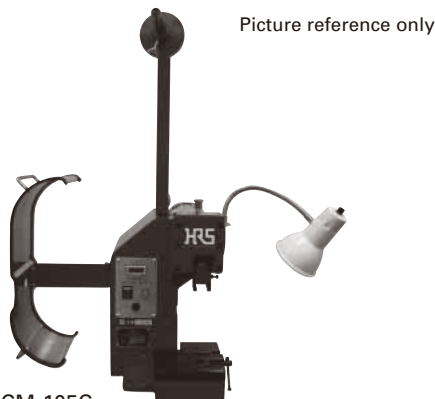

Part No. CM-105C

#### Specifications

Item	Specification	Remarks
Press capacity	1.5tons	—
Stroke Length	30mm	—
Number of strokes	200spm (50Hz)	240spm (60Hz)
Weight	75kg	—
Motor	0.2kw	AC100V
Crimping speed	2,000 to 4,000 pcs/hour	—

Terminal Product No.	Terminal HRS No.	Tool Part No.	Tool HRS No.
GT25H-2024SCF	775-0039-6	AP105-GT25H-2024S	901-5206-3
GT25HB-2428SCF	775-0070-6	AP105-GT25HB-2428S	901-5230-8

Note : Crimp height setting tables are available for each cable type. Please contact your nearest Hirose Electric account representative.  
Different cables will require different crimp height settings.

● Hand tooling



HRS No.	Part No.	Applicable wire
780-0044-1 00	HT304/GT25H-2024S	GT25H-2024SCF

Note : HT304/GT25H-2024S is rated for 0.3SQ (22 AWG) or 0.5SQ (20 AWG) cable only.  
HT304/GT25H-2024S can not terminate 0.2SQ (24 AWG) cable.