

THIS DRAWING CONTAINS INFORMATION PROPRIETARY TO RF INDUSTRIES,
 ANY UNAUTHORIZED USE OF THIS DRAWING IS EXPRESSLY PROHIBITED
 WITHOUT WRITTEN PERMISSION FROM RF INDUSTRIES.
 ANY VIOLATION IS PUNISHABLE UNDER U.S. COPYRIGHT LAWS.

ALL DIMENSIONS ARE REFERENCE ONLY

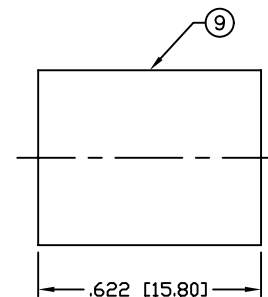
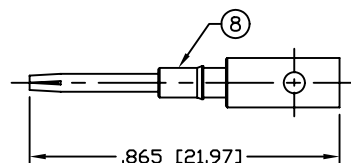
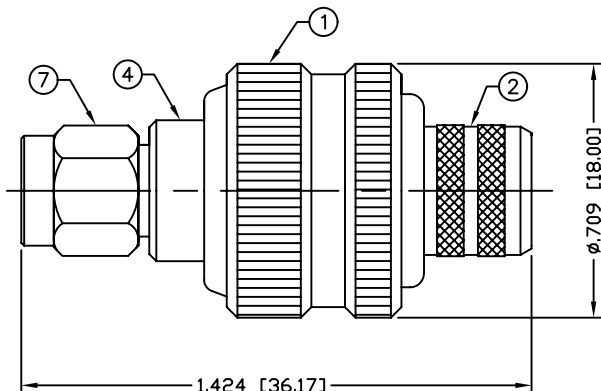

CRIMP WITH .118" or .128" CRIMP DIE
 "SOLDER ONLY" FOR RG-8/U TYPE CABLE

RECOMMENDED CRIMP DIE: .429"

SPECIFICATIONS:

IMPEDANCE: 50 Ohms
 FREQUENCY RANGE: 0-12.4 GHz
 INSERTION LOSS(dB): $0.03 \times \sqrt{f(\text{GHz})}$
 VSWR: 1.3 MAX.
 WORKING VOLTAGE: 500 V rms Max. @ Sea Level
 INSULATION RESISTANCE: 5k M Ohms min.
 TEMPERATURE RANGE: -65°C TO 85°C
 FOR BELDEN 8214, 9913, 9913F, 9914, RG-8/U TYPE,
 CAROL C1180, TIMES AA-5886 & LMR-400 CABLE

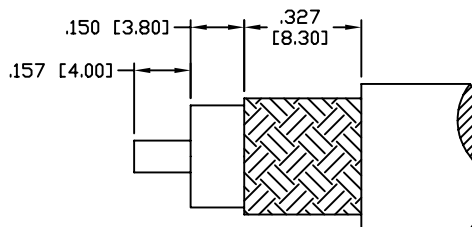

RECOMMENDED STRIPPING DIMENSIONS

1	BODY	1	BRASS	NICKEL, 100μ"	008974	
2	FERRULE STUD	1	BRASS	NICKEL, 100μ"		
3	INSULATOR	1	PTFE	----		
4	SMA BODY	1	BRASS	NICKEL, 100μ"		
5	RETAINING RING	1	Be-Cu	----		
6	GASKET	1	SILICONE	----		
7	SHELL	1	BRASS	NICKEL, 100μ"		
8	PIN	1	Be-Cu	GOLD, 50μ"		
9	FERRULE	1	BRASS	NICKEL, 100μ"		
10					DRAWN	
11					C. ZUNIGA	
12					CHECKED	
13						
14					ORJ DRAWN	
					D. McREYNOLDS	
#	DESCRIPTION	QTY	MATRL	FINISH	APPROVALS	DATE

UNLESS OTHERWISE SPECIFIED:
 1. REMOVE ALL BURRS
 2. BREAK ALL CORNERS & EDGES .005 R. MAX.
 3. CHAMFER 1ST & LAST THREADS 45°
 4. SURFACE ROUGHNESS 63 FINISH MIL-STD-10
 5. DIAMETERS ON COMMON CENTERS TO BE CONCENTRIC WITHIN .002 T.I.R.
 6. ALL DIMENSIONS ARE AFTER PLATING.

DIMENSIONS ARE IN INCHES AND [MILLIMETERS]
 UNLESS OTHERWISE NOTED TOLERANCES ARE:
 DECIMALS DIAMETER
 .XXX±.003 [.08] .XXX±.001 [.03]
 .XX±.005 [.13] .XX±.003 [.08]



7610 MIRAMAR RD
 SAN DIEGO, CA 92126
 (858) 549-6340
 (858) 549-6345 FAX

SMA PLUG, CRIMP

REVERSE POLARITY

SIZE	CABLE GROUP	DWG NO.	REV
A	I	RP-3000-I	B
SCALE:	NTS	CAD FILE	OUTLINE
SHEET 1 OF 1			

PART NO.		RP-3000-I		
REV	DESCRIPTION	DWN	DATE	APPROVED
-	ENGINEERING RELEASE	JDM	5/22/00	JDMc
A	ADD CRIMP DIE & SPECS / UPDATE DWG.	GGG	3/27/02	JDMc
B	ADDED SOLDER ONLY NOTE	CZS	08/08/06	JDMc