

- 1 MATERIAL:
BASE: THERMOPLASTIC POLYESTER, UL 94V-0 (NATURAL).
POST: COPPER ALLOY (TIN OR TIN-LEAD PLATED, .000150 MIN THK).
- 2 ONE HOLE MAY BE UNDERSIZED (.032-.035 DIA) FOR ASSEMBLY RETENTION DURING WAVE SOLDERING.
- 3. PARTS MUST COMPLY WITH AMP SOLDERABILITY SPEC 109-11-2.
- 4 PLASTIC AROUND POST PERMISSIBLE IN THIS AREA ONLY.
- 5 DIMENSION APPLIES WHEN HEADER IS HELD FLAT.
- 6 MEASURED AT -A-
- 7 COORDINATE DIMENSION APPLIES FROM CENTER OF ACTUAL FEATURE.
- 8 RADIUS AT TIP PERMITTED, BOTH ENDS.
- 9 POST MUST WITHSTAND 3.0 LB MIN AXIAL FORCE IN BOTH DIRECTIONS WITHOUT DISLOGGING.
- 10 SOLDER SIDE OF BOARD IS SHOWN.
- 11 DIMENSION SHOULD BE .060 MIN WHEN MATING WITH A MTA-100 CONNECTOR ASSEMBLY OR A CST-100 CONNECTOR.
- 12 HOLE IN OMITTED POST LOCATION MAY NOT BE PRESENT.
- 13. AMP LOGO MAY OR MAY NOT APPEAR ON MOLDING HOUSING.

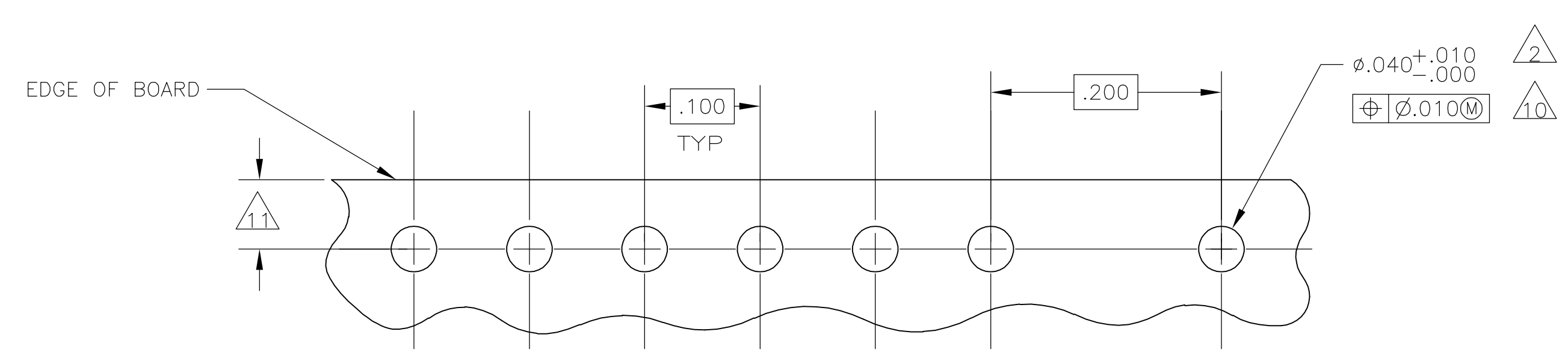

RECOMMENDED MOUNTING HOLE PATTERN FOR .063 THICK P. C. BOARD

644365-2 SHOWN

TIN	4	3-644365-3
TIN	2	3-644365-2
TIN	3	3-644365-1
FINISH	POST NO. OMITTED	PART NUMBER

THIS DRAWING IS A CONTROLLED DOCUMENT.		DWN C. MARTIN 28MAY91	28MAY91	Tyco Electronics Corporation Harrisburg, PA 17105-3608
DIMENSIONS: INCHES		CHK R. SWING 28MAY91	30MAY91	
TOLERANCES UNLESS OTHERWISE SPECIFIED:		TITLE W. GENTRY 30MAY91 NAME MTA-100 HEADER ASSEMBLY, NARROW, .025 SQUARE STRAIGHT POST, TIN-LEAD PLATED, 8 POSITION, OMITTED POST		RESTRICTED TO
0 PLC ± - 1 PLC ± - 2 PLC ± - 3 PLC ± .005 4 PLC ± - ANGLES ± -		PRODUCT SPEC APPLICATION SPEC SIZE CAGE CODE DRAWING NO A1 00779 ©=644365		
MATERIAL		WEIGHT		SCALE 10:1 SHEET 1 OF 1 REV H