

Miniature Plastic Key Lock Limit Switches Series 83 893 0 / 83 893 1 IP 67

- Key-operated safety interlock switches for monitoring the moving cover
- Plastic bodies and heads
- Heads have 4 possible positions
- Positive opening contacts

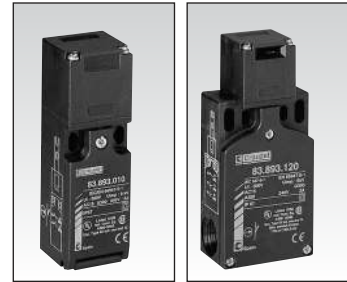

General characteristics

Environment

Conforming to standards	Products	IEC 947-5-1, EN 60 947-5-1, UL 508, CSA C22-2 no.14, JIS C4520 (See P. 2/2 and 2/3)
	Machine assemblies	IEC 204-1, EN 60 204-1, EN 1088, EN 292
Certifications		UL, CSA
Protective treatment		In normal operation: "TC"
Temperature	Use	-25°C, +70°C
	Stored	-40°C, +70°C
Vibration resistance		5 gn (10...500 Hz) according to IEC 68-2-6
Shock resistance		10 gn (duration 11 ms) according to IEC 28-2-27
Degree of protection		IP 67 according to IEC 529 and IEC 947-5-1
Cable entry		Cable gland 11

Electrical characteristics

Assigned working characteristics	AC 15 A 300 Ue = 240 V, Ie = 3A or Ue = 120 V, Ie = 6 A DC 13 Q 300 Ue = 250 V, Ie = 0.27 A or Ue = 125 V, Ie = 0.55 A
Assigned insulation voltage	Ui = 500 V according to IEC 947-5-1 Ui = 300 V according to UL 508, CSA C22-2 no. 14
Assigned impulse voltage	Uimp = 6 KV acc. to IEC 947-5-1
Thermal rating	Ithe = 10 A according to IEC 947-5-1
Electric shock protection	Class 2 according to IEC 536
Resistance between terminals	30 m according to IEC 954-5-4
Short-circuit protection	Cartridge fuse 10 A gG (gl)
Connection	Screw clamp terminals Clamping capacity min. 1 x 0.5 mm ² , max. 1.5 mm ² with or without ferrule
Electrical life	According to IEC 947-5-1 appendix C

Part numbers





Type of contact

NC+NO	2-pole contact NC+NO break before make, slow action	83 893 001
NC+NC	2-pole contact NC+NC, slow action	83 893 010
NC+NO+NO	3-pole contact NC+NO+NO (2 NO bbm) + slow action	83 893 120
NC+NC+NO	3-pole contact NC+NC+NO (NO bbm) + slow action	83 893 130

Additional characteristics

Maximum actuation speed	0.5 m/s	0.5 m/s
Minimum actuation speed	0.01 m/s	0.01 m/s
Resistance to removal of key	10 N	10 N
Mechanical life	1 million operating cycles	1 million operating cycles
Maximum operating frequency	600 operating cycles per hour	600 operating cycles per hour
Minimum positive opening force	15 N	15 N
Pg 11 cable entry according to NFC 68 300	1	2
Thermal rating (Ith)	10 A	10 A
Assigned insulation voltage (Ui)	500 V	500 V
Weight	0.110 kg	0.160 kg

Accessories

Straight key		79 214 581
Key with wide fixing bar		79 214 582
Short key with wide fixing bar		79 214 585
Angled key		79 214 584
Flexible key		79 214 583

To order, specify:

Standard products

1

Part number

Example: Safety limit switch 83 893 001 - Straight key 79 214 581

2

Accessory

Standard products, non stocked

2

Accessory

Example: Straight key 79 214 581

Products and specifications subject to change without notice.

Order/Technical Support – Tel: (800) 677-5311 / FAX: (800) 677-3865 / www.crouzet-usa.com

Dimensions

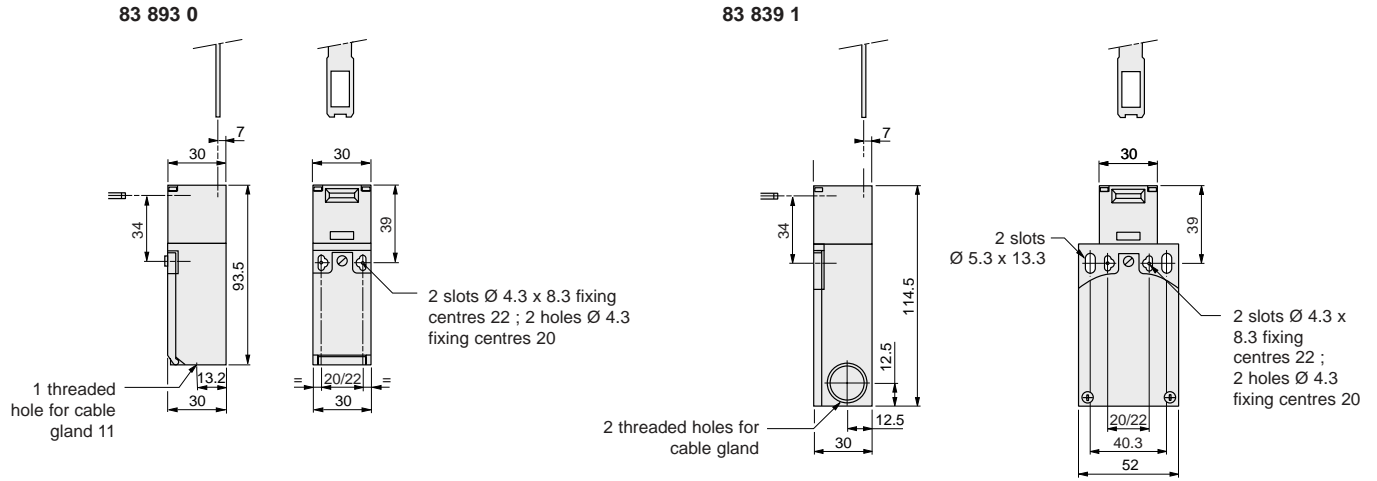

Accessories

79 214 581

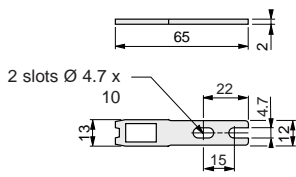

79 214 582 / 585

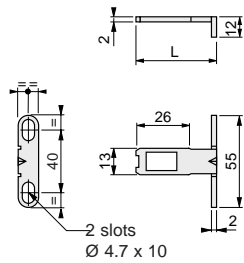

Types	Dimension L (mm)
79 214 582	40
79 214 585	29

79 214 584

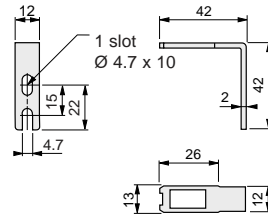

79 214 583

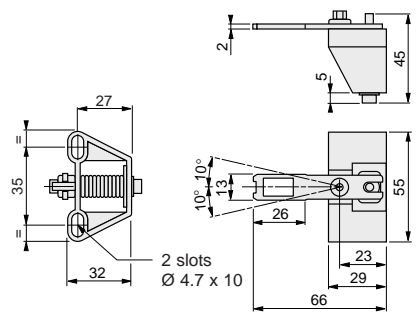

Operating radius

79 214 581

79 214 582 / 585

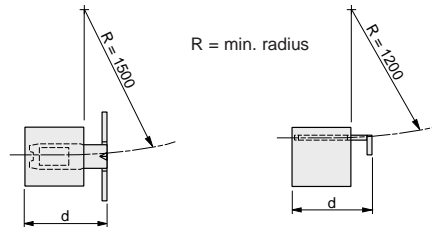
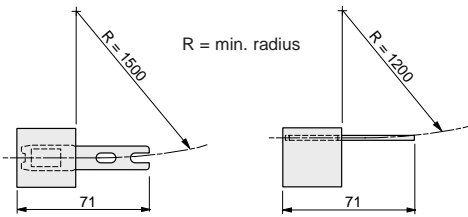

Types	Dimension d (mm)
79 214 582	46
79 214 585	35

79 214 584

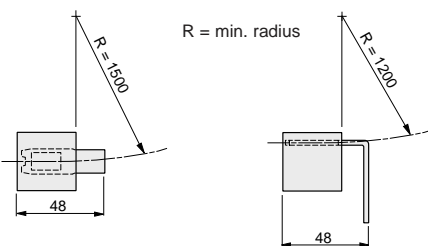

79 214 583

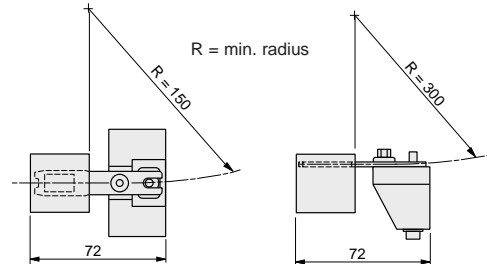

Other information

Products and specifications subject to change without notice.

Order/Technical Support – Tel: (800) 677-5311 / FAX: (800) 677-3865 / www.crouzet-usa.com