

# PRODUCT DATA DRAWING

REVISION HISTORY			
REV	DESCRIPTION	DATE	APPROVED
-	DCN 43145	03/17	GPF

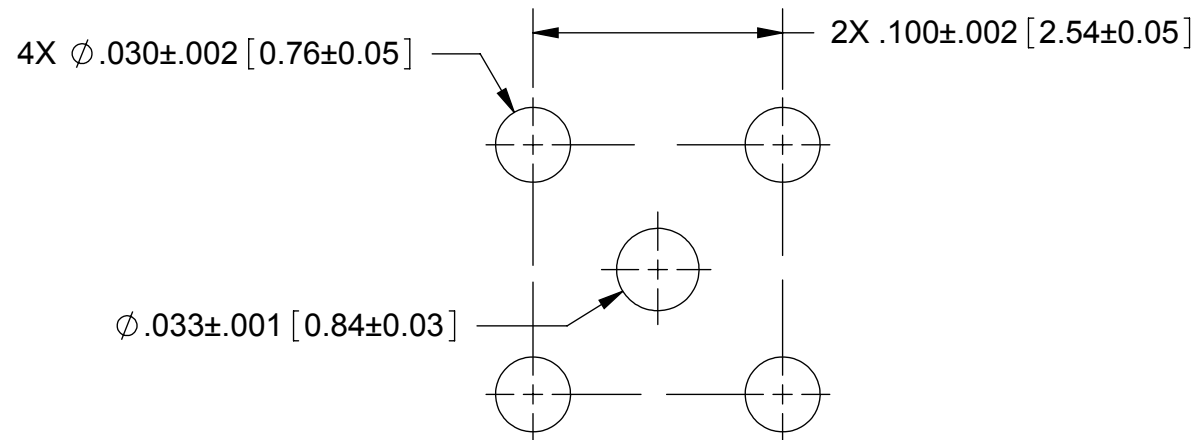

**RECOMMENDED MOUNTING HOLE PATTERN**

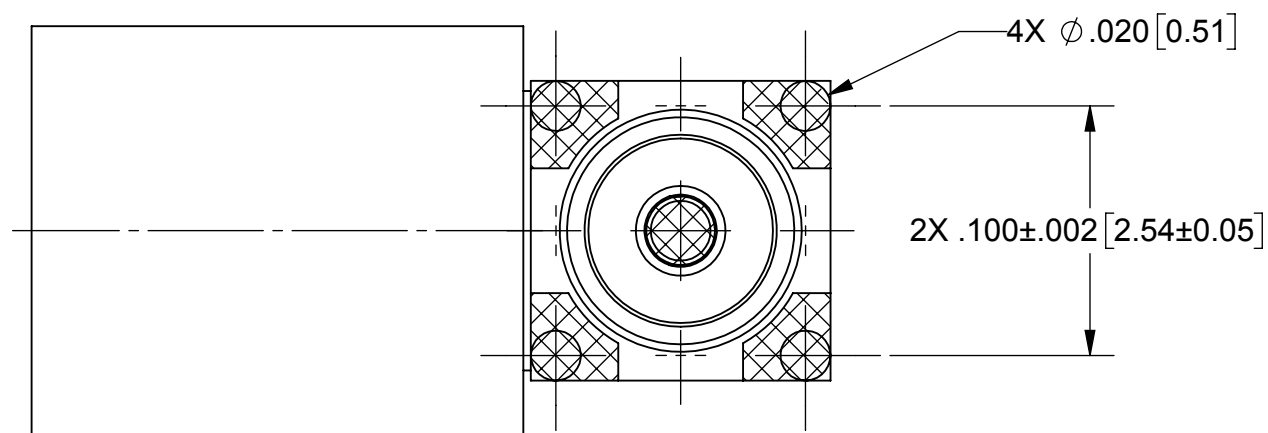
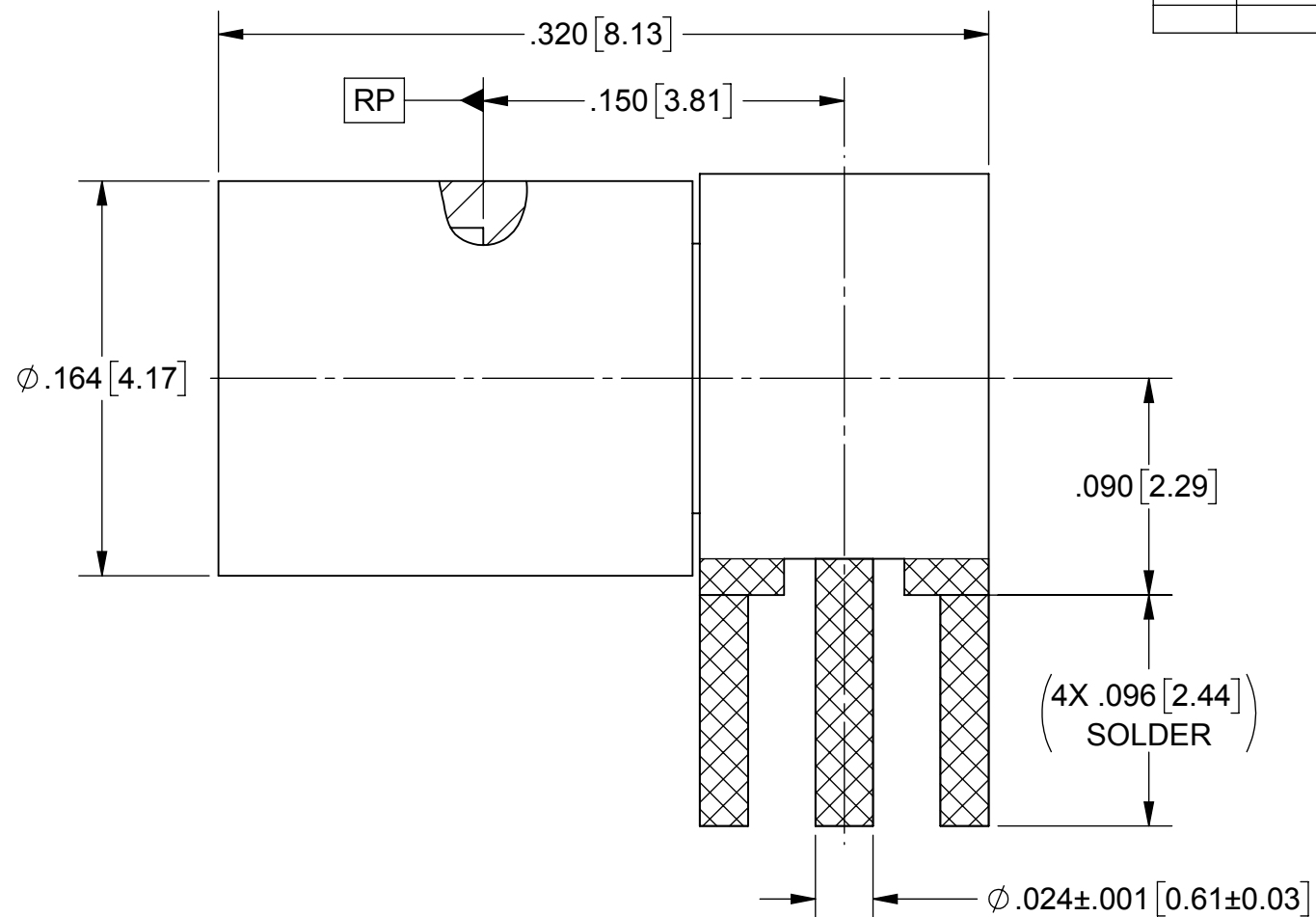

**MATERIAL:**

INTERFACE BODY: STAINLESS STEEL ALLOY S30300, TYPE 303, COND. A PER AMS-5640  
 PC LEG BODY, CONTACT & SLEEVE: BERYLLIUM COPPER PER ASTM B196, ALLOY C17300, TD 04  
 INSULATOR: PTFE PER ASTM D1710

**FINISHES:**

INTERFACE BODY: PASSIVATED PER AMS-2700, TYPE 2  
 PC LEG BODY, CONTACT & SLEEVE: GOLD PER ASTM B488, TYPE II, CODE C, CLASS 1.27; OVER NICKEL PER AMS-QQ-N-290, CLASS 1, .00005" MIN.

**PERFORMANCE:**

IMPEDANCE: 50 OHMS  
 FREQ. RANGE: DC TO 20 GHz  
 V.S.W.R.: 1.35:1 DC TO 20 GHz  
 D.W.V.: 500 VRMS  
 INSULATION RES.: 5,000 MEGOHMS MINIMUM

**NOTES:**

- TO BE TIN DIPPED USING Sn96 SOLDER
- ALL DIMENSIONS APPLY PRIOR TO SOLDER DIPPING

MATERIAL: SEE NOTES	DIMENSIONS ARE IN INCHES TOLERANCES: FRACTIONAL: ±1/64 ANGULAR: X° ±1'0" X°X' ±15'	UNLESS OTHERWISE SPECIFIED 1) ALL DIMENSIONS ARE IN INCHES (MILLIMETERS) 2) ALL DIMENSIONS ARE AFTER PLATING. 3) BREAK CORNERS & EDGES .005 R. MAX. 4) CHAM. 1ST & LAST THREADS. 5) SURFACE ROUGHNESS 63 MIL-STD-10. 6) DIA.'S ON COMMON CENTERS TO BE CONCENTRIC WITHIN .005 T.I.R. 7) REMOVE ALL BURRS	<b>SV Microwave, Inc.</b> 2400 Centrepark West Drive, Suite 100 West Palm Beach, FL 33409
FINISH: SEE NOTES	DECIMAL: .X ±.030 .XX ±.010 .XXX ±.005	INTERPRET DIMENSIONS AND TOLERANCES PER ASME Y14.5M - 1994	TITLE: SMP MALE SB R/A 4-LEG PCB MOUNT
SURFACE AREA: N/A	THIRD ANGLE PROJECTION	DRAWN: VB 03/09/17 CHECKED: GPF 03/09/17 APPROVED: GPF 03/09/17	SIZE: B CAGE CODE: 95077 DWG. NO.: SF1212-6002-TD
PROPRIETARY THE INFORMATION CONTAINED IN THIS DRAWING IS THE SOLE PROPERTY OF SV MICROWAVE, INC. ANY REPRODUCTION IN PART OR AS A WHOLE WITHOUT THE WRITTEN PERMISSION OF SV MICROWAVE, INC IS PROHIBITED.			SCALE: 13:1 SHEET 1 OF 1