

PART NUMBER	REVISION	DESCRIPTION	FEED TYPE
2150372-2	E	FINE CRIMP HEIGHT ADJUST	PNEUMATIC
7-2150372-2	E	PNEUMATIC AND CRIMP TOOLING KIT	PNEUMATIC
7-2150372-7	A	CRIMP TOOLING KIT	-

ATLANTIC VERSION TERMINATOR INTERFACE ADAPTER

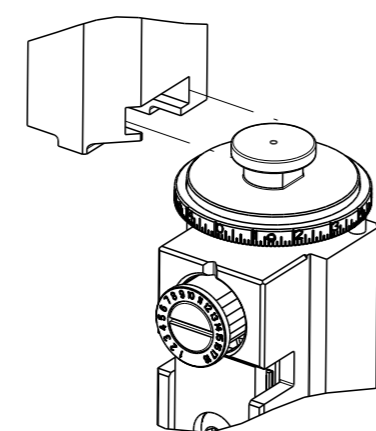

APPLICATOR DATA		
CRIMP	SIZE	TYPE
WIRE	.090 [2.29 mm]	F
INSUL	.130 [3.30 mm]	Ø
APPL INSTRUCTIONS 408-35043		

TERMINAL DATA: TE TERMINAL TE CRIMP SPECIFICATION			
TERMINAL NAME: RECEPTACLE, SHUR PLUG			
WIRE STRIP LENGTH	INSULATION DIAMETER RANGE		
.150-.181 IN [3.81-4.60 mm]	Ø.090-.120 IN [2.29-3.05 mm]		
TERMINAL APPLICATION SPECIFICATION	114-2017		
TERMINALS APPLIED			
TE TERMINAL	TE TERMINAL	TE TERMINAL	TE TERMINAL
42531-1	42531-3	42531-2	42539-1
61817-1	150639-1		

WIRE SIZE	CRIMP HEIGHT mm [INCH]	CRIMP HEIGHT REFERENCE SETTING
16 AWG	1.55+/-0.000 [.061+/- .000]	4.2
18 AWG	1.40+/-0.000 [.055+/- .000]	5.7
20 AWG	1.29+/-0.000 [.051+/- .000]	6.9



- 1 RECOMMENDED SPARE PARTS
- 2 REFER TO SUPPLIED INSTRUCTION SHEET FOR CLEANING, LUBRICATION AND STORAGE OF APPLICATOR.
- 3 APPLY PART NUMBER 2-23419-6 LOCTITE TO THREADS OF ITEM 242. APPLY PART NUMBER 1-23419-5 LOCTITE TO THREADS OF ITEM 180.
- 4 CRIMP HEIGHT REFERENCE SETTING WAS THE SETTING USED WHEN THE APPLICATOR WAS QUALIFIED AT THE FACTORY. ADJUSTMENT MAY BE NECESSARY WHEN RUNNING APPLICATOR IN THE FIELD.
- 5 TERMINAL LUBRICANT IS RECOMMENDED.
- 6. UNLESS SPECIFIED OTHERWISE TORQUE VALUES SHALL BE USED PER DOCUMENT, 101-35000.
- 7 TERMINAL PITCH NOT COMPATIBLE WITH MECHANICAL FEED.

***WARNING**
ON INSTALLATION, SET WIRE DISC TO CRIMP HEIGHT REFERENCE SETTING FOR LARGEST WIRE SIZE. CRIMP HEIGHT REFERENCE SETTINGS GREATER THAN THE VALUE SHOWN MAY CAUSE DAMAGE TO THE CRIMP TOOLING. REFER TO THE INSTRUCTION SHEET FOR PROPER SETUP AND ADJUSTMENTS.

LOC	DIST	REVISIONS					
		P	LYR	DESCRIPTION	DATE	OWN	APVD
A	66	B		ECR-15-000343	09JAN2015	JH	TE
		C		ECR-18-006601	30APR2018	AW	TE
		D		ECR-18-017920	15NOV2018	TB	CT
		E		ECR-19-009276	12JUN2019	LG	TE

-	1	1	2119641-1	FEED CAM, AIR FEED	248	
-	1	1	2119082-9	CAM, SNAIL, INSULATION ADJUSTMENT	244	
-	1	1	2079764-1	WASHER, WAVE SPRING, CREST-TO-CREST	243	
3	-	1	1	2119083-1	RETAINER, INSULATION DIAL	242
-	1	1	2844940-3	AIR FEED MODULE	238	
-	1	1	1-18028-0	WASHER, FLAT, REG M8	192	
3	-	1	1	1-1976055-9	STANDOFF, HOLD-DOWN	180
-	1	1	6-9931111-6	PIN, SLOTTED SPRING 3.0 X 14.0	177	
-	1	1	8-22280-7	SPRING, COMPRESSION	176	
-	1	1	1752353-2	GUIDE PIN,HOLDDOWN	175	
-	1	1	1901680-2	GUIDE PIN,HOLDDOWN	174	
-	REF	REF	994970-2	COUNTER, MAGNETIC	164	
5	-	1	1	2119955-2	ASSY, LUBRICATOR, END FEED	84
-	1	1	455888-5	SPACER, CRIMPER	82	
-	1	1	2119791-9	DEPRESSOR, WIRE	73	
-	1	1	1803607-4	DOCUMENTATION PACKAGE	71	
-	2	2	2-18032-2	SCR, SET, FLT PNT, M3 X 10.0	70	
-	1	1	2119943-1	WASHER, SPACER	69	
-	1	1	2119740-1	TAG, IDENTIFICATION	67	
-	2	2	2168078-1	SCREW, DRIVE, RH, RoHS, 2 x .188	66	
-	1	1	1901681-1	HOLDDOWN, TERMINAL	65	
-	1	1	2168083-2	SCR, SKT HD CAP, RoHS, M4 X 8.0	60	
-	1	1	5-18022-5	SCR, HEX HD CAP, M4 X 6.0	59	
-	4	4	2168400-4	SHCS, LOW HEAD, RoHS, M4 X 8	57	
-	2	2	2168083-8	SCR, SKT HD CAP, RoHS, M4 X 16	56	
-	2	2	5018030-1	NUT, HEX, REG, RoHS, M3	54	
-	2	2	986965-8	NUT, LOCK, HEX, TORQUE (M4)	53	
-	1	1	1-5018030-0	NUT, HEX, REG, RoHS, M3.5	52	
-	1	1	2063961-1	FEED FINGER	51	
-	1	1	18023-9	SCR, SKT HD CAP M4 X 6.0	49	
-	1	1	2119655-5	APPLICATOR BASIC ASSEMBLY, EF	46	
-	1	1	1803517-1	RAM ASSEMBLY, EF ATLANTIC	44	
-	1	1	1803602-1	SCR, BHSC, RoHS (M8 X 25)	41	
-	8	8	1-18028-2	WASHER, FLAT, REG M4	33	
-	2	2	2168083-9	SCR, SKT HD CAP, RoHS, M4 X 20	31	
-	2	2	2168083-2	SCR, SKT HD CAP, RoHS, M4 X 8.0	29	
-	1	1	240639-1	STRIPPER (MACHINING)	27	
-	2	2	1-2168083-5	SCR, SKT HD CAP, RoHS, M4 X 30	25	
-	1	1	1752371-5	PLATE, STRIP GUIDE	24	
-	2	2	2-22281-3	SPRING, COMPRESSION	22	
-	1	1	1803292-4	DRAG	20	
-	2	2	1901259-6	GUIDE, LOWER STRIP	18	
-	4	4	1-2079383-1	SCR, BHSC, RoHS (M6 X 12)	17	
-	1	1	4-240641-3	SPACER	16	
-	1	1	1752360-1	SPACER,HOLD-DOWN	13	
1	-	1	1	240644-1	PLATE, REAR SHEAR	11
1	-	2	2	1-240645-6	SPACER, SHEAR PLATE	10
1	-	1	1	1-240642-2	PLATE, FRONT SHEAR	9
1	1	2	1	3-1803000-5	ANVIL, COMBINATION, END FEED	8
1	-	1	1	9-240651-0	BLADE, SLUG	7
-	-	-	-	-	6	
-	1	1	1	8-240641-5	SPACER	5
-	1	1	1	238011-2	BLOCK, CRIMPER SPACER	4
1	1	2	1	3-1803019-1	CRIMPER, INSULATION 0	3
-	-	-	-	-	2	
1	1	2	1	4-456406-7	CRIMPER, WIRE PREMIUM	1
-	77	72	2	PART NO	DESCRIPTION	ITEM NO

ATLANTIC VERSION
Shown on sheets 1 of 4 & 2 of 4
(Pacific version shown on sheets 3 of 4 & 4 of 4)

<small>THE DRAWING IS UNPUBLISHED. IT IS SUBJECT TO CHANGE AND THE CUSTOMER IS RESPONSIBLE FOR VERIFYING THE DIMENSIONS AND TOLERANCES SHOWN ON THIS DRAWING. DIMENSIONS SHOULD BE CONTACTED FOR THE LATEST REVISION.</small>		OWN: K. STAKEM 01JUN2011 CHK: G. BAILEY 01JUN2011 APVD: M. CLIFFORD 01JUN2011 PRODUCT SPEC	TE Connectivity Harrisburg, PA 17105-3608
DIMENSIONS: mm 	TOLERANCES UNLESS OTHERWISE SPECIFIED: 0 PLC ± 1 PLC ± 2 PLC ± 3 PLC ± 4 PLC ± ANGLES FINISH ±	NAME: Ocean End Feed Applicator SIZE: A1 CAGE CODE: 00779 DRAWING NO: ©=2150372 RESTRICTED TO: -	SCALE: 1:1 SHEET: 1 of 4 REV: E
MATERIAL: -		WEIGHT: -	Customer Accessible Production Drawing

LOC	DIST	REVISIONS					
A	66	P	LYR	DESCRIPTION	DATE	OWN	APVD
		-		SEE SHEET 1	-	-	-

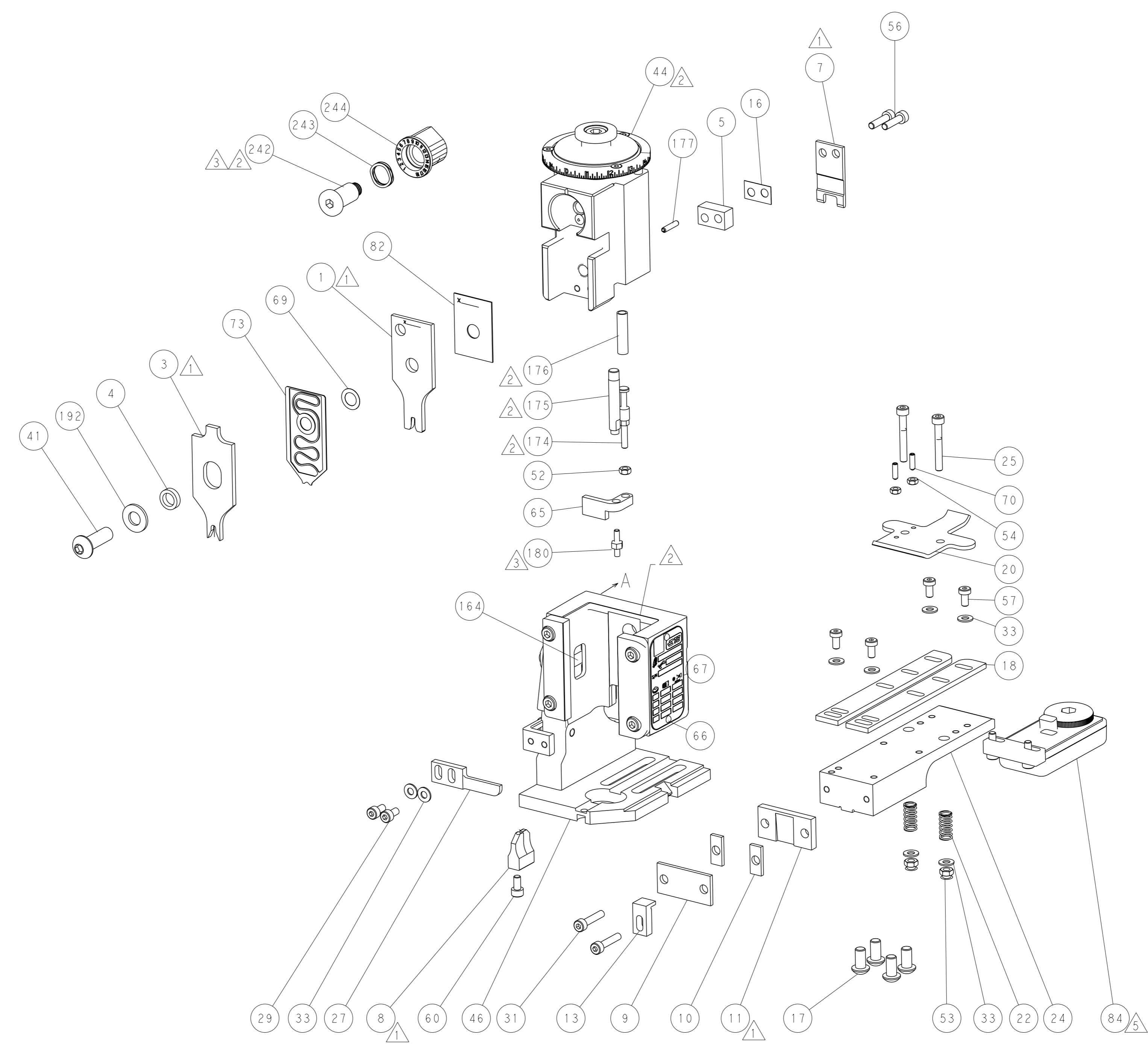
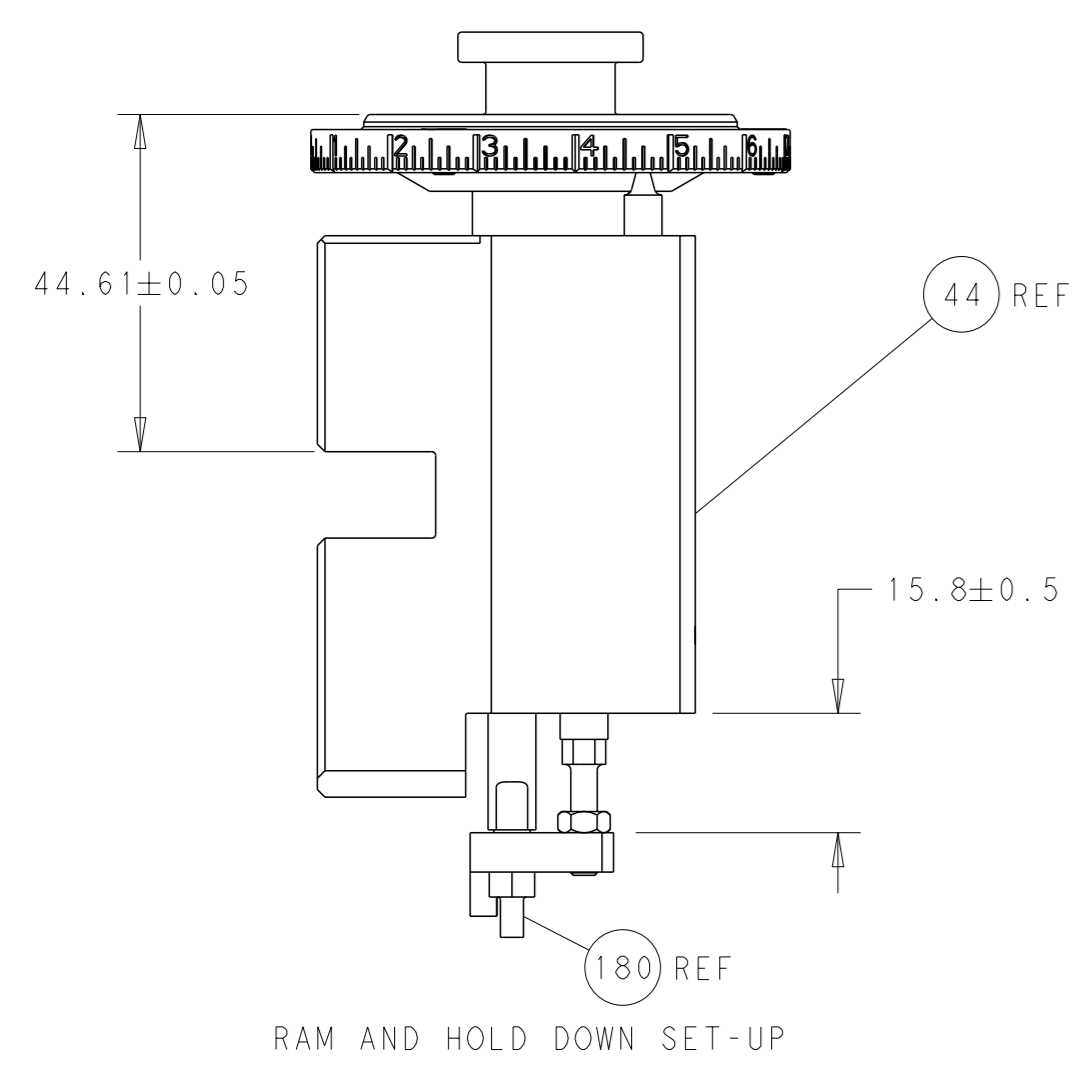

FEED TYPE

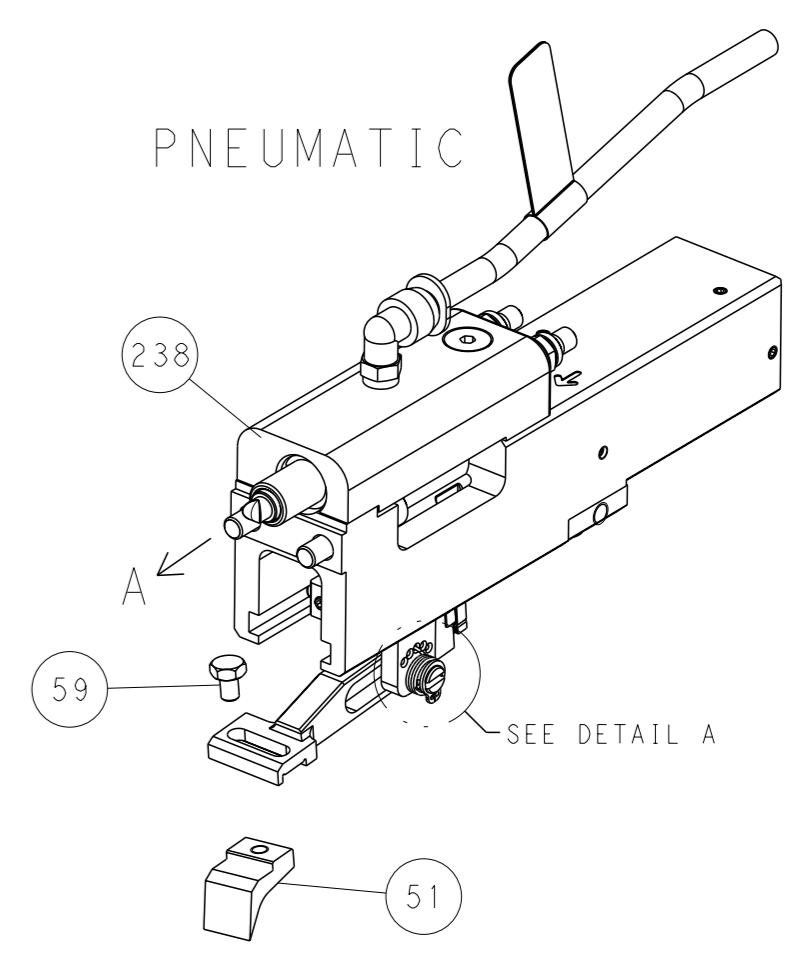

FEED SPRING SETTING POSITION

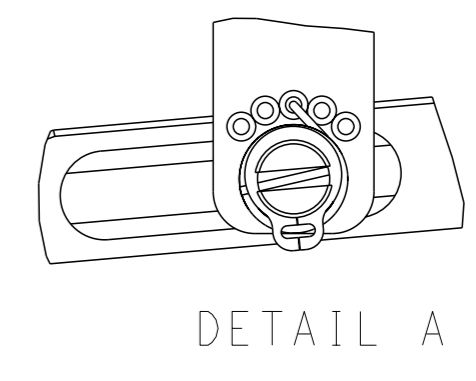

CAM POSITION

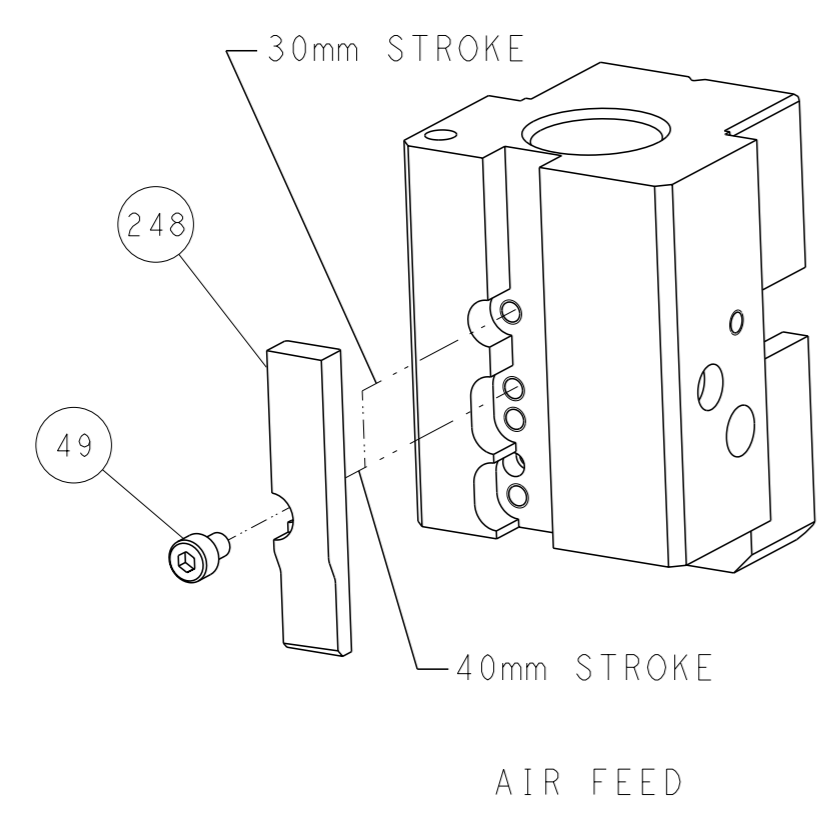

ATLANTIC VERSION
 Shown on sheets 1 of 4 & 2 of 4
 (Pacific version shown on sheets 3 of 4 & 4 of 4)

<small>THIS DRAWING IS A CONTROLLED DOCUMENT FOR TYCO ELECTRONICS CORPORATION. IT IS SUBJECT TO CHANGE AND THE CONTROL AND EXISTING DESIGNATION SHOULD BE CONTACTED FOR THE LATEST REVISION.</small>		OWN: K. STAKEM 01JUN2011 CHK: G. BAILEY 01JUN2011 APVD: M. CLIFFORD 01JUN2011	NAME: Ocean End Feed Applicator SIZE: A1 CAGE CODE: 00779 DRAWING NO: 2150372	TE Connectivity Harrisburg, PA 17105-3608
DIMENSIONS: mm TOLERANCES UNLESS OTHERWISE SPECIFIED: 0 PLC ± 1 PLC ± 2 PLC ± 3 PLC ± 4 PLC ± ANGLES FINISH ±	TOLERANCES UNLESS OTHERWISE SPECIFIED: 0 PLC ± 1 PLC ± 2 PLC ± 3 PLC ± 4 PLC ± ANGLES FINISH ±	PRODUCT SPEC APPLICATION SPEC WEIGHT Customer Accessible Production Drawing	RESTRICTED TO SCALE: 1:1 SHEET 2 OF 4 REV E	

PART NUMBER	REVISION	DESCRIPTION	FEED TYPE
2-2150372-2	E	FINE CRIMP HEIGHT ADJUST	PNEUMATIC
7-2150372-7	A	CRIMP TOOLING KIT	-

PACIFIC VERSION TERMINATOR
 INTERFACE ADAPTER

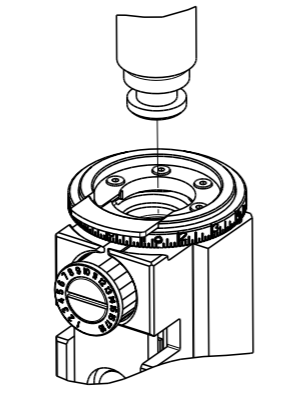

APPLICATOR DATA

CRIMP	SIZE	TYPE
WIRE	.090 [2.29 mm]	F
INSUL	.130 [3.30 mm]	O

APPL INSTRUCTIONS
 408-35043

TERMINAL DATA: TE TERMINAL TE CRIMP SPECIFICATION

TERMINAL NAME: RECEPTACLE, SHUR PLUG

WIRE STRIP LENGTH	INSULATION DIAMETER RANGE
.150-.181 IN [3.81-4.60 mm]	Ø.090-.120 IN [2.29-3.05 mm]

TERMINAL APPLICATION SPECIFICATION

TE TERMINAL	TE TERMINAL	TE TERMINAL	TE TERMINAL
42531-1	42531-3	42531-2	42539-1
61817-1	150639-1		

WIRE SIZE	CRIMP HEIGHT mm [INCH]	CRIMP HEIGHT REFERENCE SETTING
16 AWG	1.55+/-0.000 [.061+/- .000]	4.2
18 AWG	1.40+/-0.000 [.055+/- .000]	5.7
20 AWG	1.29+/-0.000 [.051+/- .000]	6.9

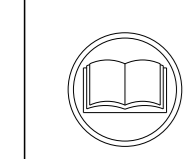

- RECOMMENDED SPARE PARTS
- REFER TO SUPPLIED INSTRUCTION SHEET FOR CLEANING, LUBRICATION AND STORAGE OF APPLICATOR.
- APPLY PART NUMBER 2-23419-6 LOCTITE TO THREADS OF ITEM 242. APPLY PART NUMBER 1-23419-5 LOCTITE TO THREADS OF ITEM 180.
- CRIMP HEIGHT REFERENCE SETTING WAS THE SETTING USED WHEN THE APPLICATOR WAS QUALIFIED AT THE FACTORY. ADJUSTMENT MAY BE NECESSARY WHEN RUNNING APPLICATOR IN THE FIELD.
- TERMINAL LUBRICANT IS RECOMMENDED.
- UNLESS SPECIFIED OTHERWISE TORQUE VALUES SHALL BE USED PER DOCUMENT, 101-35000.
- TERMINAL PITCH NOT COMPATIBLE WITH MECHANICAL FEED.

***WARNING**
 ON INSTALLATION, SET WIRE DISC TO CRIMP HEIGHT REFERENCE SETTING FOR LARGEST WIRE SIZE. CRIMP HEIGHT REFERENCE SETTINGS GREATER THAN THE VALUE SHOWN MAY CAUSE DAMAGE TO THE CRIMP TOOLING. REFER TO THE INSTRUCTION SHEET FOR PROPER SETUP AND ADJUSTMENTS.

LOC	DIST	REVISONS
A	66	

			DESCRIPTION	DATE	OWN	APVD
-	1	2119082-9	CAM, SNAIL, INSULATION ADJUSTMENT			
-	1	2079764-1	WASHER, WAVE SPRING, CREST-TO-CREST			
-	1	2119083-1	RETAINER, INSULATION DIAL			
-	1	2844940-3	AIR FEED MODULE			
-	1	1-18028-0	WASHER, FLAT, REG M8			
-	4	2079383-9	SCR, BHSC, RoHS (M6 X 20)			
-	1	1-1976055-9	STANDOFF, HOLD-DOWN			
-	1	6-9931111-6	PIN, SLOTTED SPRING 3.0 X 14.0			
-	1	8-22280-7	SPRING, COMPRESSION			
-	1	1752353-2	GUIDE PIN, HOLDDOWN			
-	1	1901680-2	GUIDE PIN, HOLDDOWN			
-	REF	994970-2	COUNTER, MAGNETIC			
-	1	2119641-2	FEED CAM, AIR FEED			
-	1	2168083-8	SCR, SKT HD CAP, RoHS, M4 X 16			
-	1	2119656-6	APPLICATOR BASIC ASSEMBLY, EF			
-	1	1803518-1	RAM ASSEMBLY, EF PACIFIC			
-	1	2119955-2	ASSY, LUBRICATOR, END FEED			
-	1	455888-5	SPACER, CRIMPER			
-	1	2119791-9	DEPRESSOR, WIRE			
-	1	1803607-4	DOCUMENTATION PACKAGE			
-	2	2-18032-2	SCR, SET, FLT PNT, M3 X 10.0			
-	1	2119943-1	WASHER, SPACER			
-	1	2119740-1	TAG, IDENTIFICATION			
-	2	2168078-1	SCREW, DRIVE, RH, RoHS, 2 x .188			
-	1	1901681-1	HOLDDOWN, TERMINAL			
-	1	5-18022-5	SCR, HEX HD CAP, M4 X 6.0			
-	4	2168400-4	SHCS, LOW HEAD, RoHS, M4 X 8			
-	2	2168083-8	SCR, SKT HD CAP, RoHS, M4 X 16			
-	2	5018030-1	NUT, HEX, REG, RoHS, M3			
-	2	986965-8	NUT, LOCK, HEX, TORQUE (M4)			
-	1	1-5018030-0	NUT, HEX, REG, RoHS, M3.5			
-	1	2063961-1	FEED FINGER			
-	1	18023-9	SCR, SKT HD CAP M4 X 6.0			
-	1	1803602-1	SCR, BHSC, RoHS (M8 X 25)			
-	8	1-18028-2	WASHER, FLAT, REG M4			
-	2	2168083-9	SCR, SKT HD CAP, RoHS, M4 X 20			
-	2	2168083-2	SCR, SKT HD CAP, RoHS, M4 X 8.0			
-	1	240639-1	STRIPPER (MACHINING)			
-	2	1-2168083-5	SCR, SKT HD CAP, RoHS, M4 X 30			
-	1	1752371-5	PLATE, STRIP GUIDE			
-	2	2-22281-3	SPRING, COMPRESSION			
-	1	1803292-4	DRAG			
-	2	1901259-6	GUIDE, LOWER STRIP			
-	1	4-240641-3	SPACER			
-	1	1752360-1	SPACER, HOLD-DOWN			
-	1	240644-1	PLATE, REAR SHEAR			
-	2	1-240645-6	SPACER, SHEAR PLATE			
-	1	1-240642-2	PLATE, FRONT SHEAR			
1	1	3-1803000-5	ANVIL, COMBINATION, END FEED			
-	1	9-240651-0	BLADE, SLUG			
-	-	-	-			
-	1	8-240641-5	SPACER			
-	1	238011-2	BLOCK, CRIMPER SPACER			
1	1	3-1803019-1	CRIMPER, INSULATION O			
-	-	-	-			
1	1	4-456406-7	CRIMPER, WIRE PREMIUM			
-	-	-	-			
-	-	-	-			

PACIFIC VERSION
 Shown on sheets 3 of 4 & 4 of 4
 (Atlantic version shown on sheets 1 of 4 & 2 of 4)

DIMENSIONS: mm TOLERANCES UNLESS OTHERWISE SPECIFIED: 0 PLC ± 1 PLC ± 2 PLC ± 3 PLC ± 4 PLC ± ANGLES FINISH ±		DWN R. STAKEM 01JUN2011 CHK G. BAILEY 01JUN2011 APVD M. CLIFFORD 01JUN2011 PRODUCT SPEC APPLICATION SPEC WEIGHT SCALE 1:1 SHEET 3 OF 4 REV E		NAME Ocean End Feed Applicator SIZE CAGE CODE DRAWING NO A1 00779 C=2150372 RESTRICTED TO Customer Accessible Production Drawing	
--	--	--	--	---	--

LOC	DIST	REVISIONS				
A	66	REV	DESCRIPTION	DATE	OWN	APVD
		-	SEE SHEET 1	-	-	-

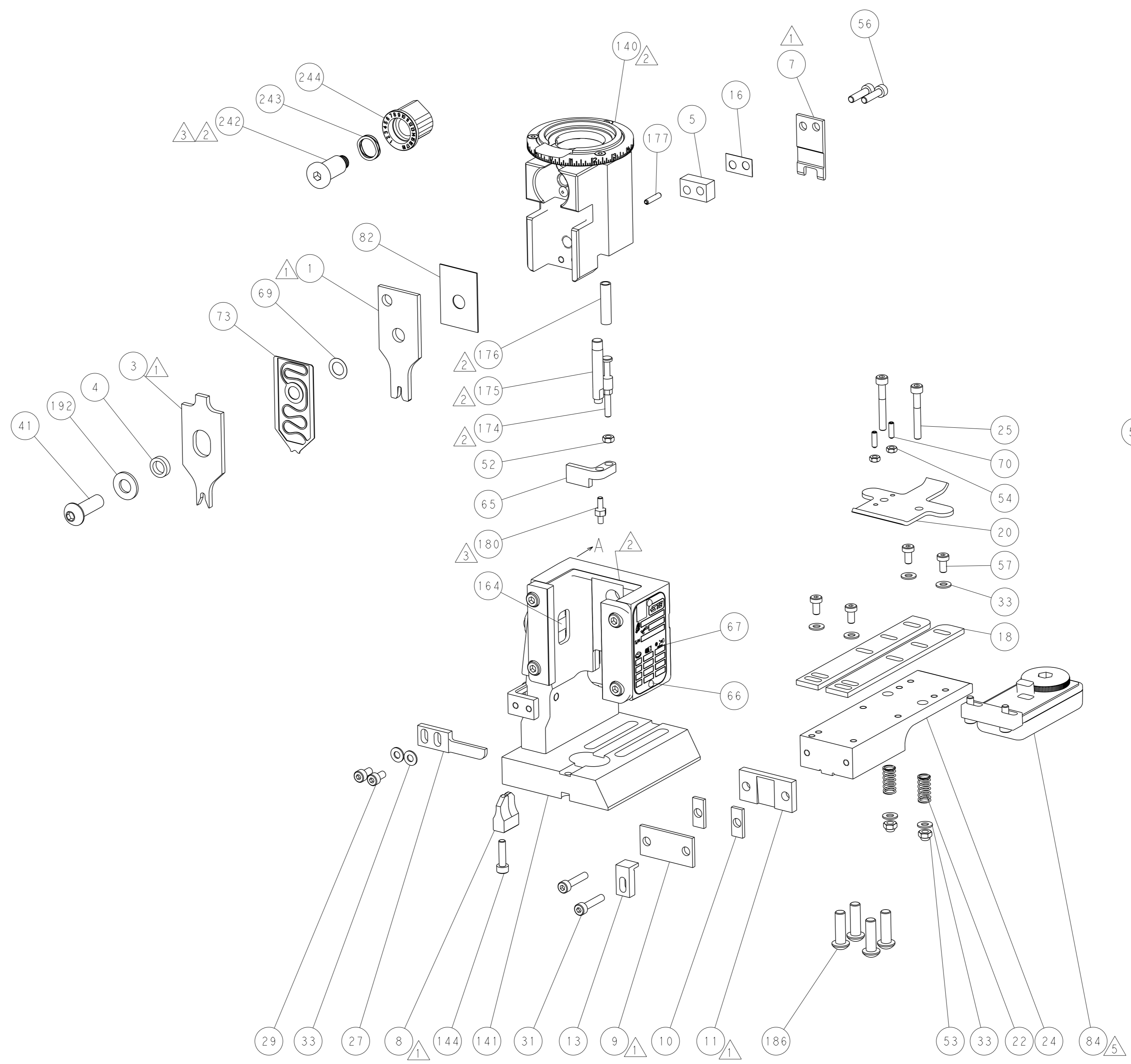
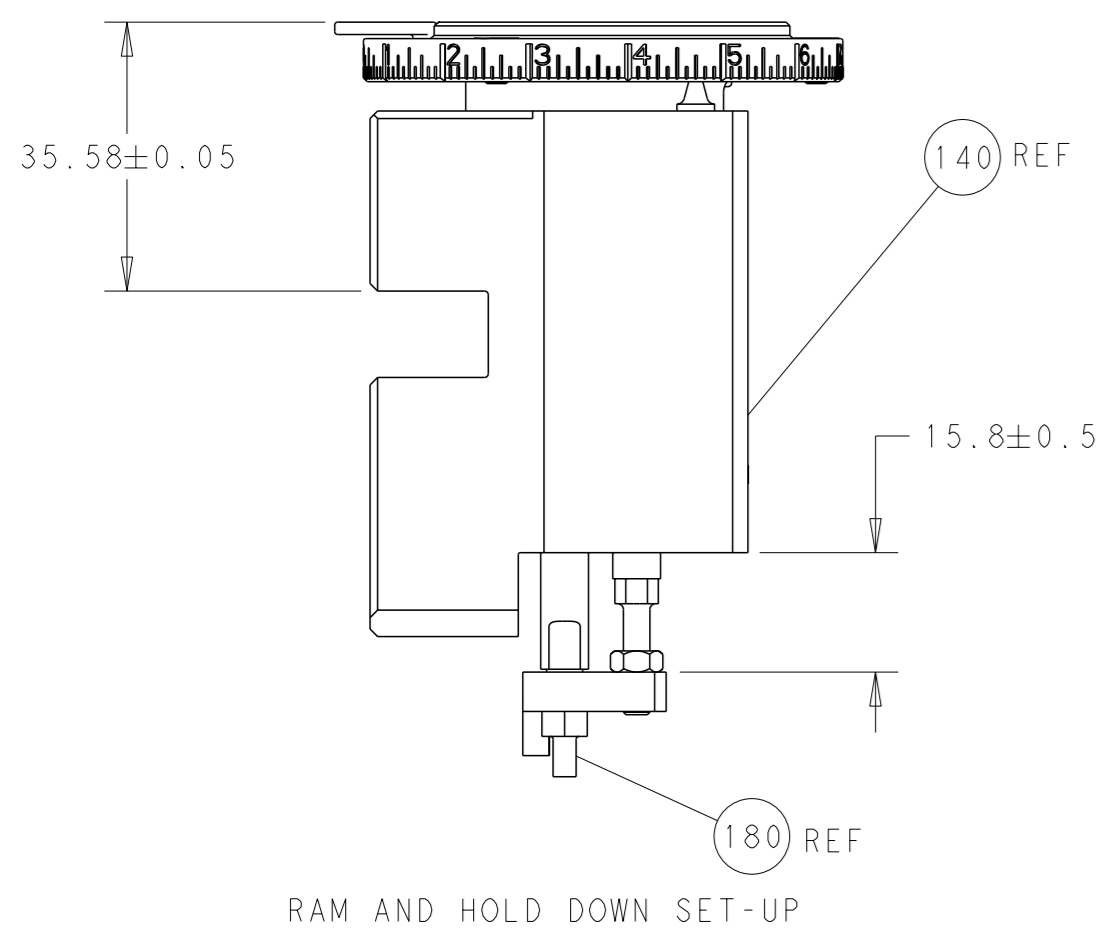

FEED TYPE

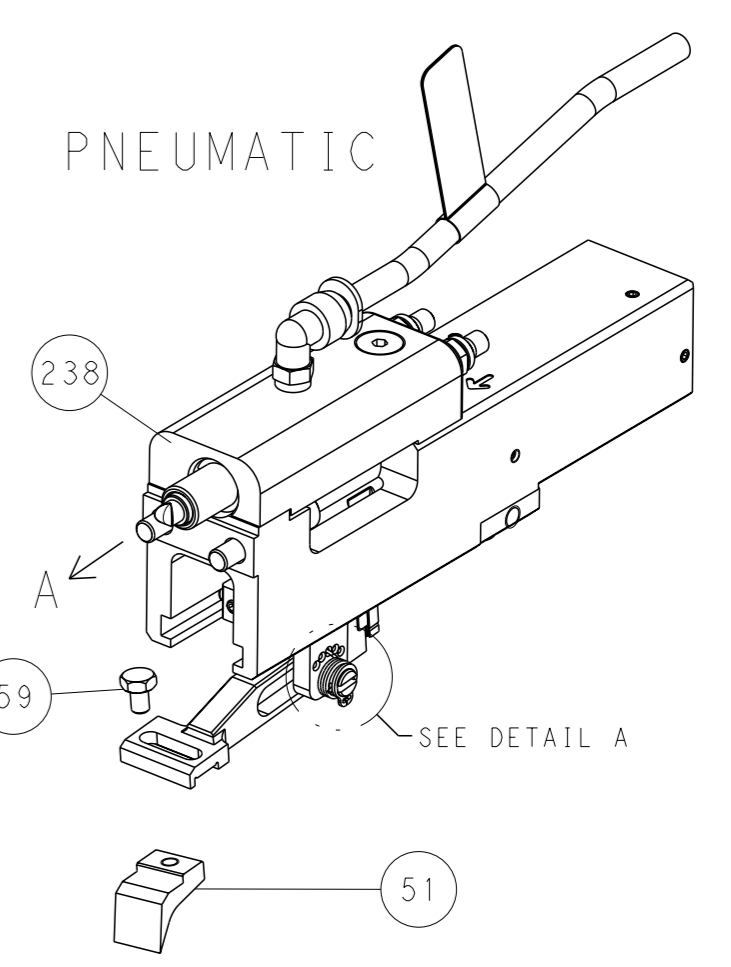

FEED SPRING SETTING POSITION

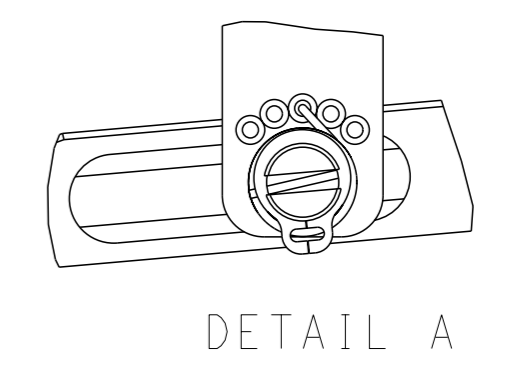

CAM POSITION

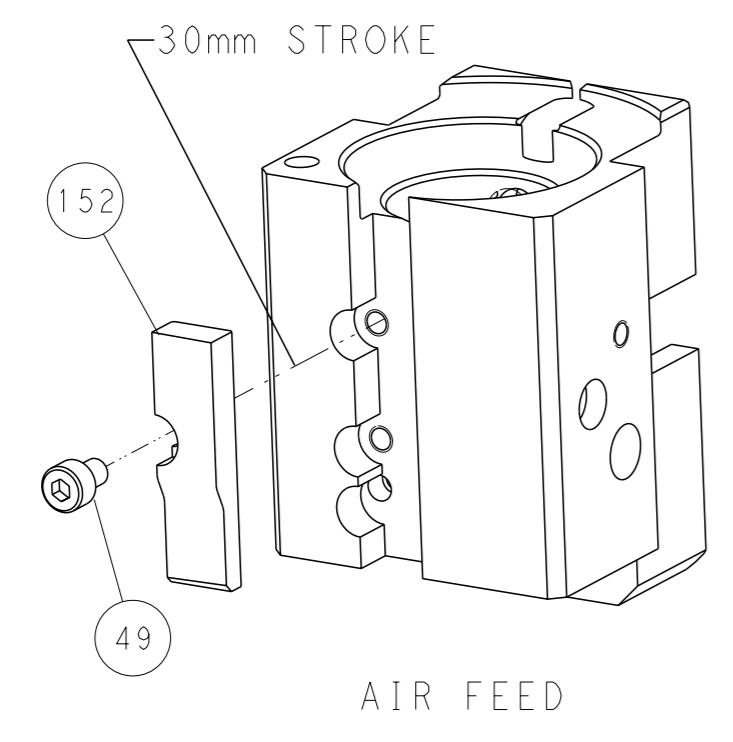

PACIFIC VERSION
 Shown on sheets 3 of 4 & 4 of 4
 (Atlantic version shown on sheets 1 of 4 & 2 of 4)

<small>THIS DRAWING IS UNPUBLISHED. RELEASED FOR PUBLICATION BY TYCO ELECTRONICS CORPORATION. ALL RIGHTS RESERVED.</small>		OWN: K. STAKEM CHK: G. BAILEY APVD: M. CLIFFORD	DATE: 01JUN2011 NAME: Ocean End Feed Applicator
DIMENSIONS: mm TOLERANCES UNLESS OTHERWISE SPECIFIED: 0 PLC ± 1 PLC ± 2 PLC ± 3 PLC ± 4 PLC ± ANGLES FINISH ±	WEIGHT: - SCALE: 1:1	SIZE: A1 CAGE CODE: 00779 DRAWING NO: C=2150372	RESTRICTED TO: - SHEET: 4 of 4 REV: E