

ACPL-0873

Three-Channel Digital Filter for Sigma-Delta Modulators

Description

The Broadcom[®] ACPL-0873 is a 3-channel digital filter designed specifically for Second Order Sigma-Delta Modulators in voltage and current sensing. Each input channel can receive an independent Sigma-Delta (Σ - Δ) modulator bit stream. The bit streams are processed by three individual digital decimation filters. Features of the digital filter include four decimation ratios for Sinc2 mode and three decimation ratios for Sinc3 mode, offset calibration, and fast over-range detection.

The ACPL-0873 outputs an over-current signal for three channels, signaling over-voltage/current conditions. Through SPI compatible interface, ACPL-0873 can directly connect to a microcontroller to output 16 bits digital filter data and write/read filter registers.

Features

- Direct interface between Isolated Sigma-Delta Modulator and MCU/DSP
- Three individual digital filters
- Fast over-range detection
- Offset calibration
- Channel 1 MCLK clock detection at power up
- Programmable input configuration
- SPI-compatible interface
- Compact surface-mount QFN-20 5 mm × 5 mm

Specifications

- Operating temperature –40°C to 125°C
- SPI clock frequency up to 17 MHz
- Modulator clock frequency up to 25 MHz

Applications

- Motor phase and rail current sensing
- Power inverter current and voltage sensing
- Industrial process control
- Data acquisition systems
- General voltage or current sensing

Schematic Diagram and Package Pin Out

Figure 1: Schematic Diagram and Package Pin Out

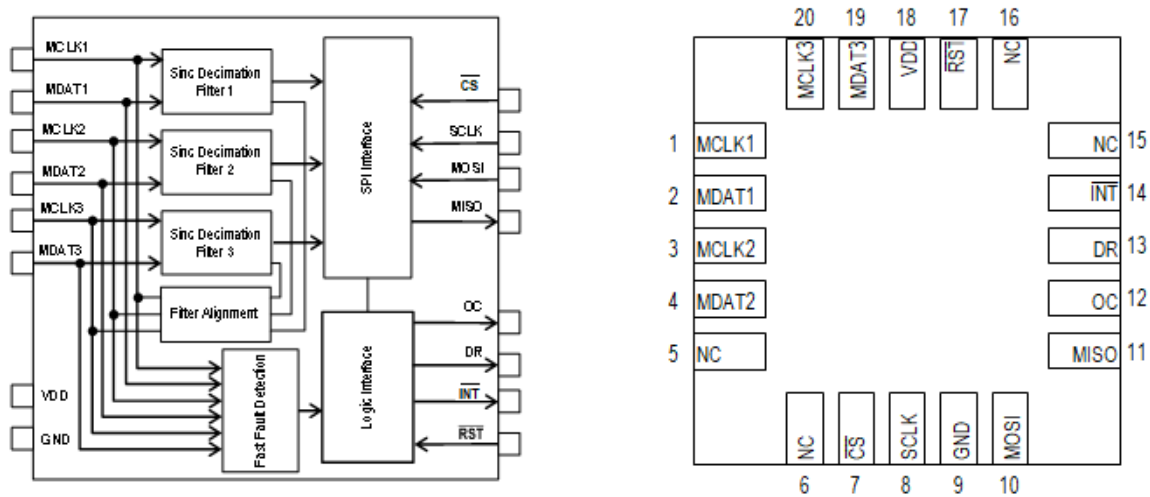

NOTE: 0.1- μ F and 1- μ F bypass capacitors between VDD and GND are recommended.

Table 1: Pin Function Description

Pin No.	Pin Name	Description	Type
1	MCLK1	Channel 1 Clock	Input
2	MDAT1	Channel 1 Data. Input Data on MDAT1 is clocked in on the rising edge of MCLK1.	Input
3	MCLK2	Channel 2 Clock	Input
4	MDAT2	Channel 2 Data. Input Data on MDAT2 is clocked in on the rising edge of MCLK2.	Input
5	NC	Not connected	
6	NC	Not connected	
7	$\overline{\text{CS}}$	Chip Select, Active Low of Chip Select for SPI interface and digital filter conversion start on the falling edge of CS.	Input
8	SCLK	SPI Clock input	Input
9	GND	Ground	Power Input
10	MOSI	SPI data Master Out Slave In	Input
11	MISO	SPI data Master In Slave Out	Output
12	OC	Over-Current	Output
13	DR	Data Ready. 1. DR pin High indicates Digital Filter data conversion ready. 2. DR pin is automatically cleared to Low when $\overline{\text{CS}}$ goes high.	Output
14	$\overline{\text{INT}}$	Interrupt, Active Low.	Output
15	NC	Not connected	
16	NC	Not connected	
17	$\overline{\text{RST}}$	Reset. Active Low, period 100 μ s at least.	Input
18	VDD	Power Supply	Power Input
19	MDAT3	Channel 3 Data. Input Data on MDAT3 is clocked in on the rising edge of MCLK3.	Input
20	MCLK3	Channel 3 Clock	Input

Figure 2: ACPL-0873 Package Outline Drawing

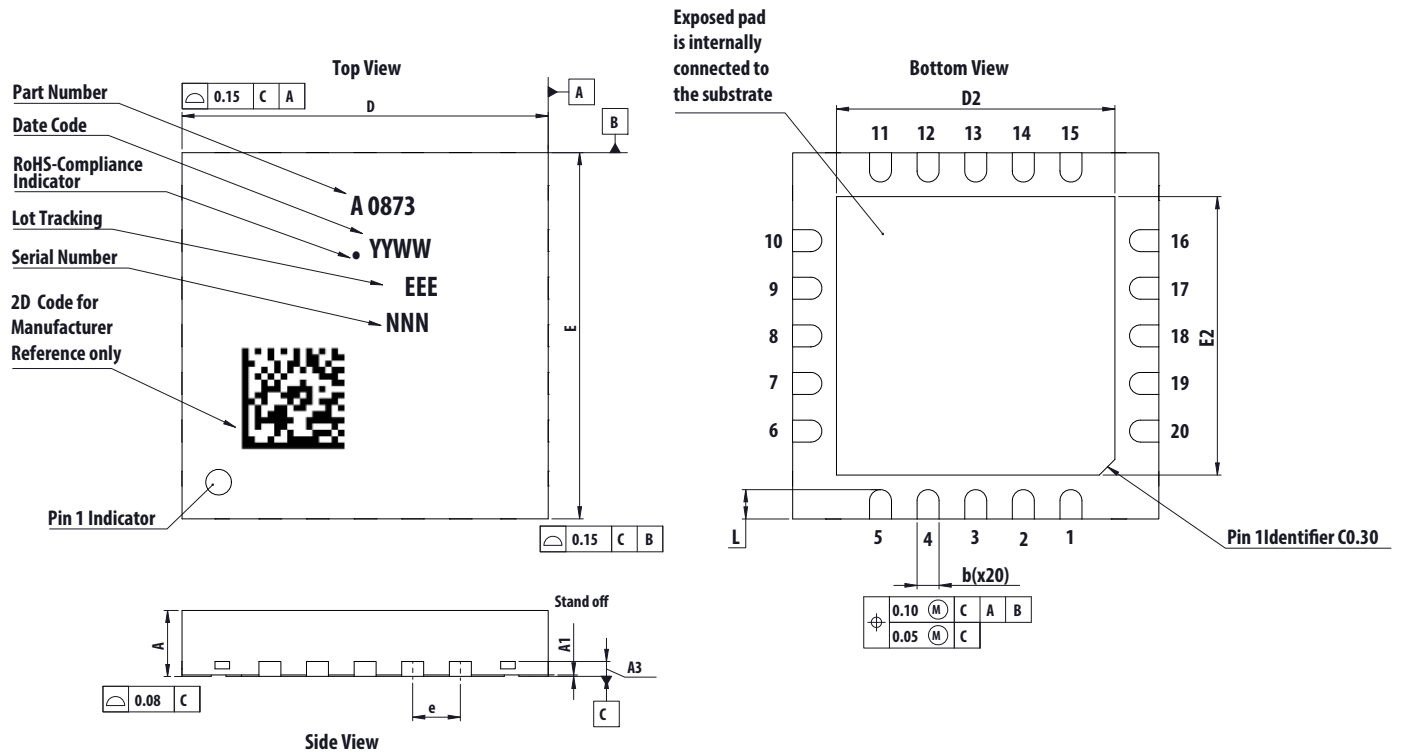
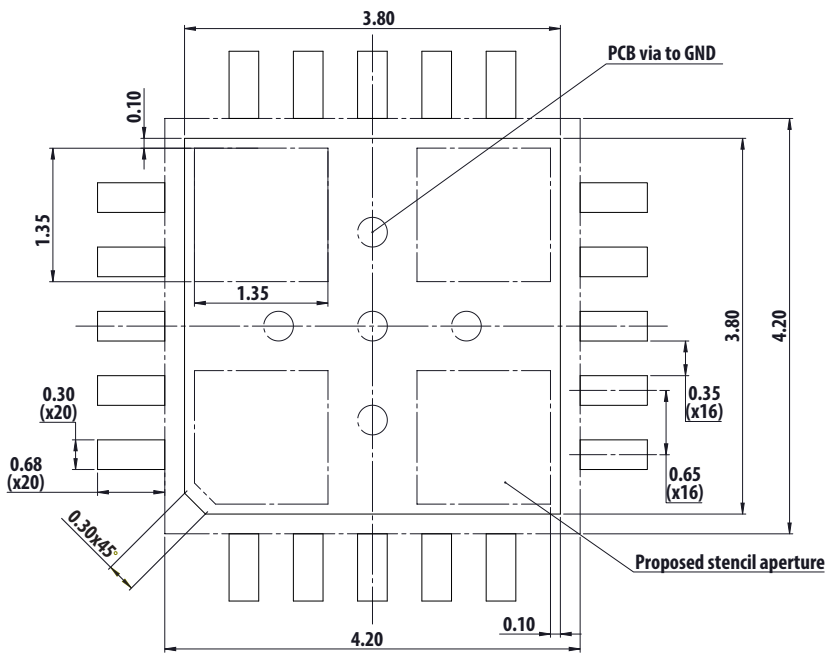

Figure 3: Recommended Land Pattern



NOTE: Connect all NC pins to GND.

Table 2: Dimensions

	Dimensions					
	Millimeter			Inch		
	Min.	Nom.	Max.	Min.	Nom.	Max.
A	0.850	0.900	0.950	0.033	0.035	0.037
A1	0.000	0.020	0.040	0.000	0.001	0.002
A3	0.203 REF			0.008 REF		
b	0.250	0.300	0.35	0.010	0.012	0.014
D	4.850	5.000	5.150	0.191	0.197	0.203
E	4.850	5.000	5.150	0.191	0.197	0.203
D2	3.700	3.800	3.900	0.146	0.150	0.154
E2	3.700	3.800	3.900	0.146	0.150	0.154
e	0.650 REF			0.026 REF		
L	0.350	0.400	0.450	0.014	0.016	0.018

Ordering Information

Part Number	Option (RoHS Compliant)	Package	Surface Mount	Tape and Reel	Quantity
ACPL-0873	-500E	QFN-20	X	X	2000 per reel

To order, choose a part number from the part number column and combine with the desired option from the option column to form an order entry.

Example:

ACPL-0873-500E to order product of QFN-20 Surface Mount package in Tape and Reel packaging with RoHS compliant. Contact your Broadcom sales representative or authorized distributor for information.

Recommended Pb-Free IR Profile

Recommended reflow condition as per JEDEC Standard, J-STD-020 (latest revision).

NOTE: Non-halide flux should be used

Absolute Maximum Ratings

Parameter	Symbol	Min.	Max.	Units	Note
Storage Temperature	T_S	-55	150	°C	
Junction Temperature	T_J	-55	150	°C	
Ambient Operating Temperature	T_A	-40	125	°C	
Supply Voltage	V_{DD}	-0.5	6	Volts	
Input Voltage	All Inputs	-0.5	$V_{DD} + 0.5$	Volts	a
Output Voltage	All Outputs	-0.5	$V_{DD} + 0.5$	Volts	a

a. Do not exceed 6V.

Recommended Operating Conditions

Parameter	Symbol	Min.	Max.	Units	Figure	Notes
Ambient Operating Temperature	T_A	-40	125	°C		
Supply Voltage	V_{DD}	3	5.5	Volts		
Input / Output Voltage		0	V_{DD}	Volts		

DC Electrical Specifications

All minimum/maximum specifications are at recommended operating conditions. Unless otherwise noted, all typical values at $T_A = 25^\circ\text{C}$, $V_{DD} = 3.3\text{V}$.

Parameter	Symbol	Min.	Typ.	Max.	Units	Test Conditions	Figure	Note
Power Supply Current	I_{DD1}	—	3.6	8	mA	3 channels $f_{MCLK} = 20\text{ MHz}$, SPI $f_{SCLK} = 17\text{ MHz}$	7	
	I_{DD2}	—	3	6.5		3 channels $f_{MCLK} = 20\text{ MHz}$, no SPI clock		
Quiescent Power Supply Current	I_{DDQ}	—	—	1	μA	All 3 channels MCLK and MDAT short to GND, no SPI clock		
Input Voltage High Level	V_{IH}	$0.7 \times V_{DD}$	—	—	Volts			
Input Voltage Low Level	V_{IL}	—	—	$0.3 \times V_{DD}$	Volts			
DC Input Current	I_{IN}	—	—	10	μA			
Output Voltage High	V_{OH}	$0.8 \times V_{DD}$	—	—	V	$I_{OH} = 4\text{ mA}$		
Output Voltage Low	V_{OL}	—	—	0.4	V	$I_{OL} = 4\text{ mA}$		

Switching Specifications

All minimum/maximum specifications are at recommended operating conditions. All input signals are specified with $t_R = t_F = 5$ ns (10% to 90% of V_{DD}) and timed at 50% voltage level. Unless otherwise noted, all typical values at $T_A = 25^\circ\text{C}$, $V_{DD} = 3.3\text{V}$.

Parameter	Symbol	Min.	Typ.	Max.	Units	Test Conditions	Figure	Note
Modulator Clock Frequency	f_{MCLK}	—	—	25	MHz			
Modulator Clock Duty Cycle	DC_{MCLK}	40	—	70	%			
MDAT Setup Time before MCLK Rising Edge	t_{MDAT_S}	10	—	—	ns		4	
MDAT Hold Time after MCLK Rising Edge	t_{MDAT_H}	3	—	—	ns		4	
SPI Clock Frequency	f_{SCLK}	—	—	17	MHz	$4.5\text{V} \leq V_{DD} \leq 5.5\text{V}$		
		—	—	13		$3.0\text{V} \leq V_{DD} \leq 5.5\text{V}$		
SPI Clock Duty Cycle	DC_{SCLK}	40	—	60	%			
SPI MOSI Setup Time	t_{MOSI_S}	3	—	—	ns		5	
SPI MOSI Hold Time	t_{MOSI_H}	3	—	—	ns		5	
SPI Clock Falling Edge to MISO Valid	t_{MISO_V}	—	—	20	ns	$4.5\text{V} \leq V_{DD} \leq 5.5\text{V}$	6	
		—	—	28		$3.0\text{V} \leq V_{DD} \leq 5.5\text{V}$		
Delay Time from \overline{CS} Low to First Rising Edge of SCLK	t_{D1}	150	—	—	ns		12, 13	
Delay Time from Last Rising Edge of SCLK to CS High	t_{D2}	150	—	—	ns		12, 13, 14	
Delay Time from DR high to Start of First SCLK	t_{DR}	150	—	—	ns		14	
Chip Select High Time	t_{CS_H}	200	—	—	ns		15	

Figure 4: MDAT and MCLK Timing Chart

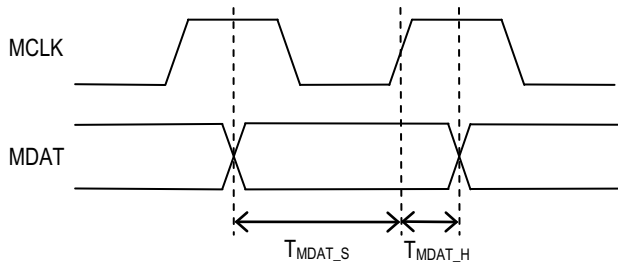

Figure 5: SPI Input Write Timing Chart

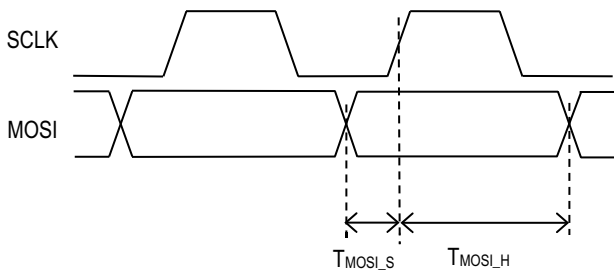

Figure 6: SPI Output Read Timing Chart

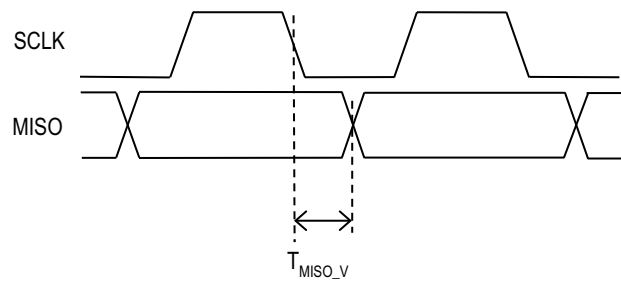
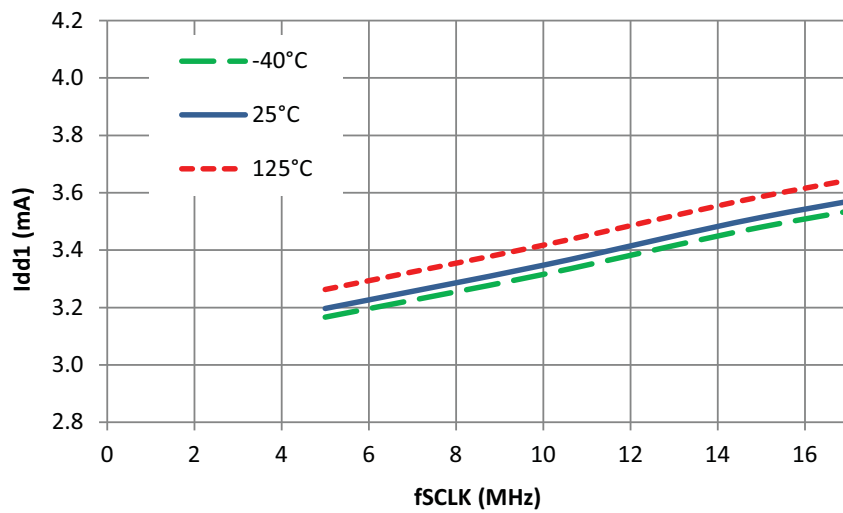

Figure 7: Power Supply Current vs. SPI Clock Frequency



Register Set

Register Address	Description	Default Value	Type
0x00	Filter setting	0x00	Read/Write
0x01	Channel selection & over-range setting	0x00	Read/Write
0x02	Interrupt status	0x00	Read Only
0x03	Interrupt enable	0x80	Read/Write
0x04	Offset Register for Channel 1 (MSB byte)	0x80	Read Only
0x05	Offset Register for Channel 1 (LSB byte)	0x00	Read Only
0x06	Offset Register for Channel 2 (MSB byte)	0x80	Read Only
0x07	Offset Register for Channel 2 (LSB byte)	0x00	Read Only
0x08	Offset Register for Channel 3 (MSB byte)	0x80	Read Only
0x09	Offset Register for Channel 3 (LSB byte)	0x00	Read Only

Register 0 (Address 0): Filter Setting

7	6	5	4	3	2	1	0
NA	Cal	Off_en	NA	Filter	NA	DC1	DC0

Default: 0x00 (Read/Write)

Filter	DC1	DC0	Decimation Ratio	Filter Type
0	0	0	1024	SINC2
0	0	1	512	SINC2
0	1	0	256	SINC2
0	1	1	128	SINC2
1	0	0	256	SINC3
1	0	1	128	SINC3
1	1	0	64	SINC3

Filter	Filter Type
0	Sinc2 Filter
1	Sinc3 Filter

Off_en	Offset Enable
0	Filter data without offset
1	Filter data with offset

Cal	Calibration Offset and Store in Offset Registers
0	No offset action
1	Capture offset data and store in Offset Registers

Register 1 (Address 1): Channel Selection and Over-Range Setting

7	6	5	4	3	2	1	0
OV3	OV2	OV1	OV0	NA	NA	SEL1	SEL0

Default: 0x00 (Read/Write)

SEL1	SEL0	Channel Filter Operation Selection
0	0	Channel 1 Only
0	1	Channel 1 Only
1	0	Channel 1 and Channel 2 only
1	1	Channel 1, Channel 2, and Channel 3

OV3	OV2	OV1	OV0	Persistence of Continuous "1" or "0" Bit in MDAT Bit Stream
0	0	0	0	0 (No over-range detection)
0	0	0	1	2
0	0	1	0	4
0	0	1	1	6
0	1	0	0	8
0	1	0	1	10
0	1	1	0	12
0	1	1	1	14
1	0	0	0	16
1	0	0	1	18
1	0	1	0	20
1	0	1	1	22
1	1	0	0	24
1	1	0	1	26
1	1	1	0	28
1	1	1	1	30

NOTE: OV setting applied to channel 1, channel 2, and channel 3

Register 2 (Address 2): Interrupt Status

7	6	5	4	3	2	1	0
NA	NA	NA	NA	OV_CH3	OV_CH2	OV_CH1	DR

Default: 0x00 (Read only)

DR	Data Ready
0	Data not ready (ADC conversion in progress or not started)
1	ADC data ready to output

OV_CH1	Over-Range Trigger Status for Channel 1
0	No trigger for Channel 1 over-range
1	Triggered for Channel 1 over-range

OV_CH2	Over-Range Trigger Status for Channel 2
0	No trigger for Channel 2 over-range
1	Triggered for Channel 2 over-range

OV_CH3	Over-Range Trigger Status for Channel 3
0	No trigger for Channel 3 over-range
1	Triggered for Channel 3 over-range

NOTE:

- Interrupt status flag cleared after read from Interrupt register.
- Data Ready status for channel 1, channel 2, and channel 3. DR status output to DR pin.
- If more than one channel is turned on, Data Ready is from the slowest channel.

Register 3 (Address 3): Interrupt Enable

7	6	5	4	3	2	1	0
MCLK1_E	NA	NA	NA	OV_CH3_E	OV_CH2_E	OV_CH1_E	DR_E

Default: 0x80 (Read/Write)

DR_E	Data Ready
0	Data Ready signal not output to Interrupt Pin $\overline{\text{INT}}$
1	Data Ready signal output to Interrupt Pin $\overline{\text{INT}}$

OV_CH1_E	Over-Range Trigger Status for Channel 1
0	Trigger for Channel 1 over-range status not output to $\overline{\text{INT}}$
1	Trigger for Channel 1 over-range status output to $\overline{\text{INT}}$

OV_CH2_E	Over-Range Trigger Status for Channel 2
0	Trigger for Channel 2 over-range status not output to $\overline{\text{INT}}$
1	Trigger for Channel 2 over-range status output to $\overline{\text{INT}}$

OV_CH3_E	Over-Range Trigger Status for Channel 3
0	Trigger for Channel 3 over-range status not output to $\overline{\text{INT}}$
1	Trigger for Channel 3 over-range status output to $\overline{\text{INT}}$

MCLK1_E	MCLK1 Activity Enable
0	MCLK1 Activity not output to Interrupt pin $\overline{\text{INT}}$
1	MCLK1 Activity output to Interrupt pin $\overline{\text{INT}}$ (default)

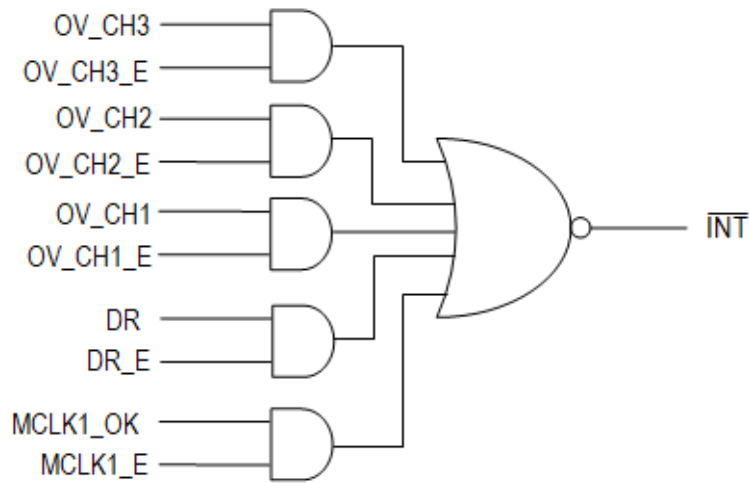
Figure 8: Interrupt Pin Implementation**Interrupt Pin Notes:**

- Interrupt output is active low.
- '0' = Check for interrupt status.
- '1' = No interrupt.

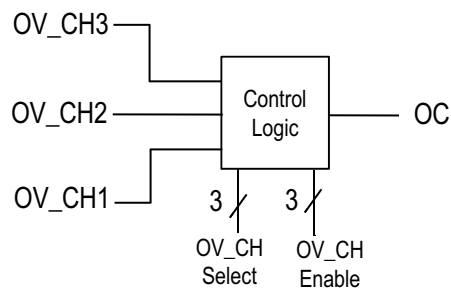
Figure 9: Over-Current Pin Implementation

1. OV_CH1/2/3 status flag is cleared by reading the Register 2.
2. OC pin is cleared by SPI \overline{CS} High to Low Transition.

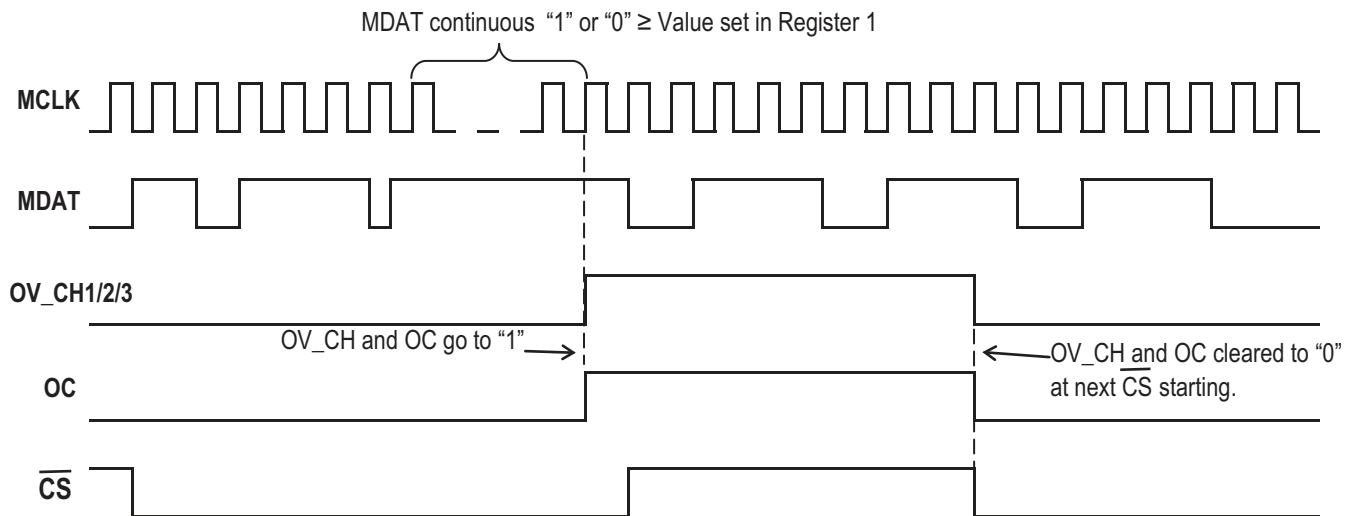
Figure 10: Over-Range Detection Chart**Register 4 (Address 4): Offset Register for Channel 1 (MSB Byte)**

7	6	5	4	3	2	1	0
off_15	off_14	off_13	off_12	off_11	off_10	off_9	off_8

Default: 0x80 (Read Only)

Register 5 (Address 5): Offset Register for Channel 1 (LSB Byte)

7	6	5	4	3	2	1	0
off_7	off_6	off_5	off_4	off_3	off_2	off_1	off_0

Default: 0x00 (Read Only)

Register 6 (Address 6): Offset Register for Channel 2 (MSB Byte)

7	6	5	4	3	2	1	0
off_15	off_14	off_13	off_12	off_11	off_10	off_9	off_8

Default: 0x80 (Read Only)

Register 7 (Address 7): Offset Register for Channel 2 (LSB Byte)

7	6	5	4	3	2	1	0
off_7	off_6	off_5	off_4	off_3	off_2	off_1	off_0

Default: 0x00 (Read Only)

Register 8 (Address 8): Offset Register for Channel 3 (MSB Byte)

7	6	5	4	3	2	1	0
off_15	off_14	off_13	off_12	off_11	off_10	off_9	off_8

Default: 0x80 (Read Only)

Register 9 (Address 9): Offset Register for Channel 3 (LSB Byte)

7	6	5	4	3	2	1	0
off_7	off_6	off_5	off_4	off_3	off_2	off_1	off_0

Default: 0x00 (Read Only)

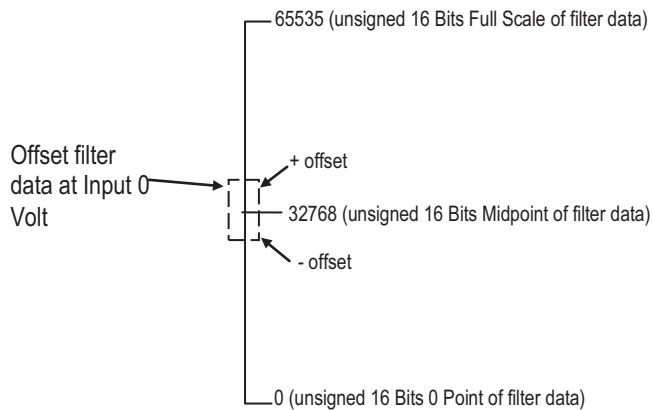
Figure 11: Offset Filter Data

SPI – Write to Registers Timing Chart

Figure 12: SPI Writing to Registers Timing Chart

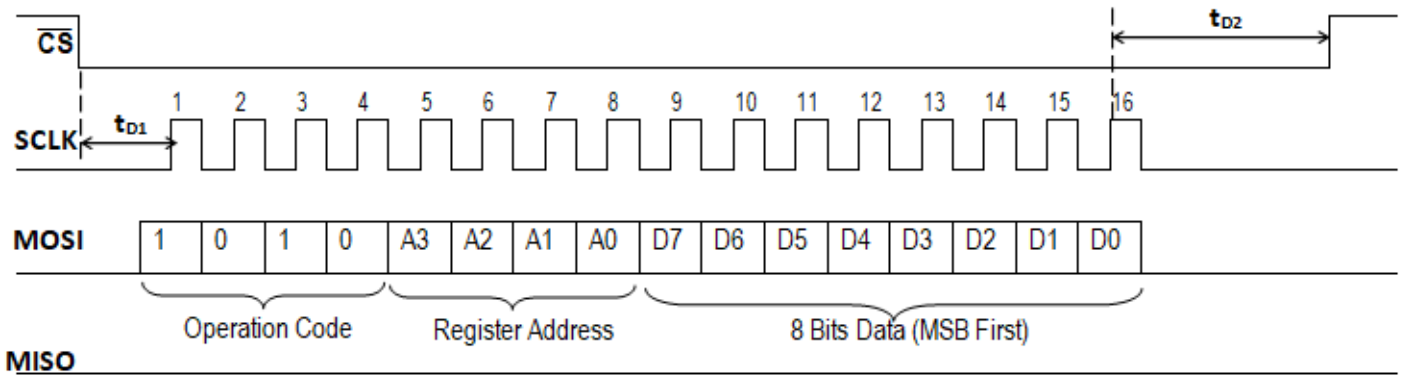

Operation code	1010
----------------	------

A3	A2	A1	A0	Register Address
0	0	0	0	0x00
0	0	0	1	0x01
0	0	1	1	0x03

8 bits data (MSB first)	D7	D6	D5	D4	D3	D2	D1	D0
-------------------------	----	----	----	----	----	----	----	----

After \overline{CS} goes low, write/read must be in the multiple 16 bits (16 cycles of SCLK).

SPI – Read from Register Timing Chart

Figure 13: SPI Read from Registers Timing Chart

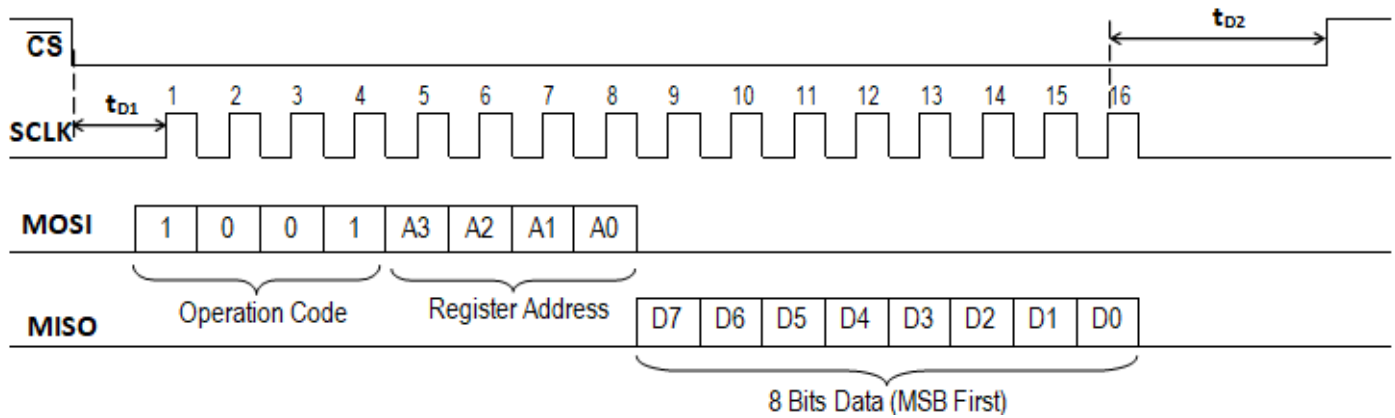

Operation code	1001
----------------	------

A3	A2	A1	A0	Register Address
0	0	0	0	0x00
0	0	0	1	0x01
0	0	1	0	0x02
0	0	1	1	0x03
0	1	0	0	0x04
0	1	0	1	0x05
0	1	1	0	0x06
0	1	1	1	0x07
1	0	0	0	0x08
1	0	0	1	0x09

8 bits data (MSB first)	D7	D6	D5	D4	D3	D2	D1	D0
-------------------------	----	----	----	----	----	----	----	----

SPI – Read from Filter's Data Timing Chart

Figure 14: SPI Read from Filter's Data Timing Chart

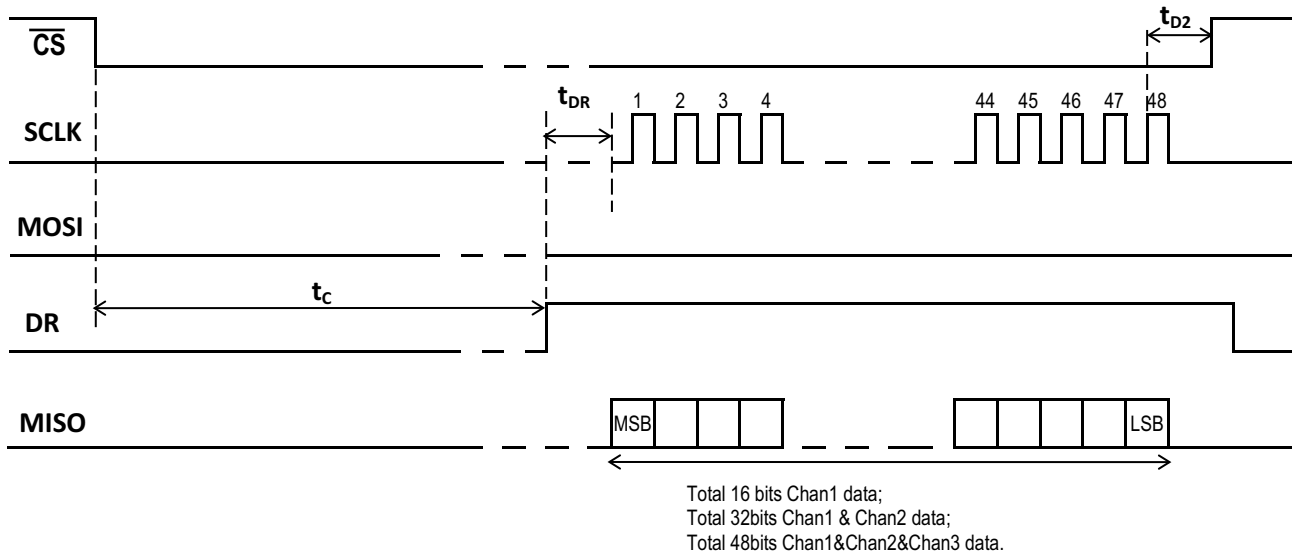

Chan 1 data	16 Bits Chan1 filter data
-------------	---------------------------

Chan1 data and Chan2 data	16 bits Chan1 filter data	16 bits Chan2 filter data
---------------------------	---------------------------	---------------------------

Chan1 data and Chan2 data and Chan3 data	16 bits Chan1 filter data	16 bits Chan2 filter data	16 bits Chan3 filter data
--	---------------------------	---------------------------	---------------------------

- Filter conversion start after falling edge of \overline{CS} signal.
- After data ready, filters data can be read out in the multiple of 16 bits.
- \overline{CS} signal has two functions: filter conversion start and chip select for SPI interface.
- When \overline{CS} is low, write from and read to registers are allowed.

SPI – Combined Operation: Write/Read Register and Read from Filter's Data Timing Chart

Figure 15: SPI Combined Operation: Write/Read Register and Read from Filter's Data Timing Chart

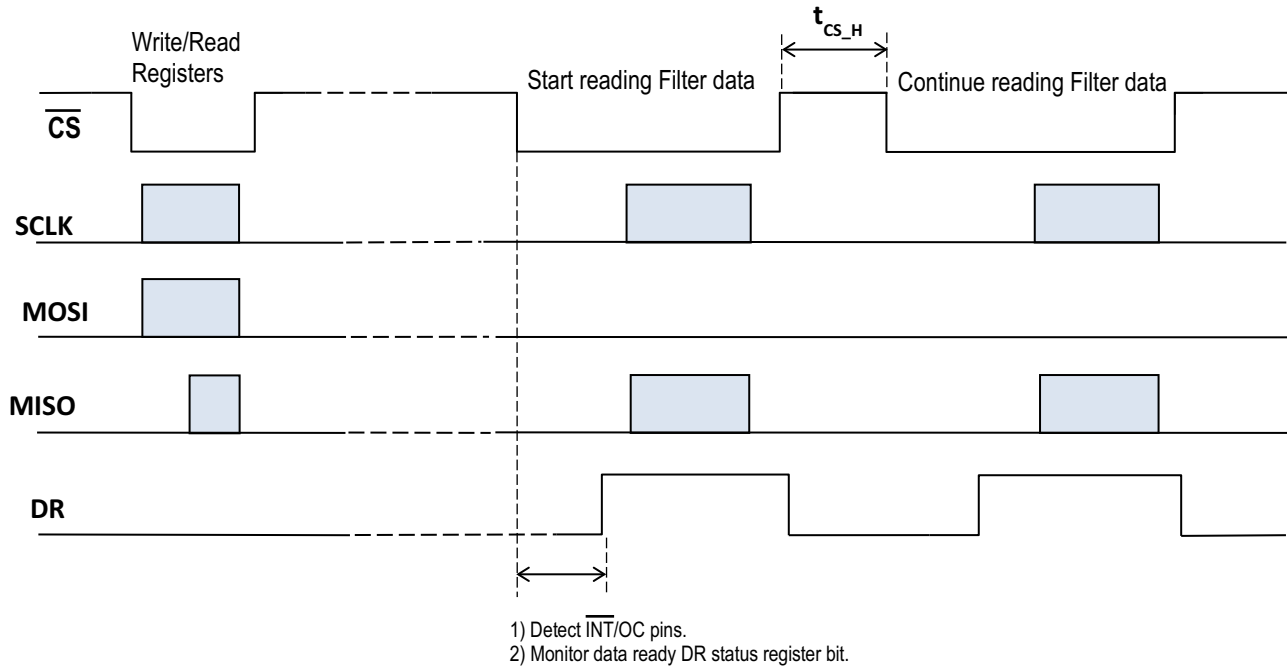

Total 16 bits Chan1 data;
 Total 32bits Chan1 & Chan2 data;
 Total 48bits Chan1&Chan2&Chan3 data.

SPI – Offset Calibration Operation

Figure 16: SPI Offset Calibration Operation

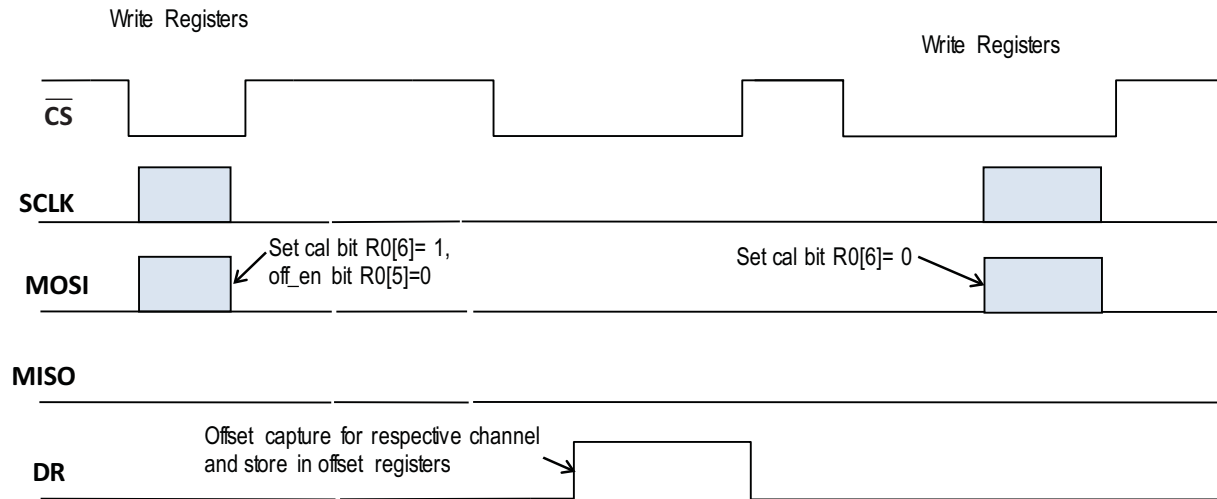

- Physically short Sigma-Delta Modulator input pins V_{in+} and V_{in-} to GND1.
- Set cal bit R0[6] = 1, Set off_en bit R0[5] = 0, Set filter setting to Sinc3 Decimation Ratio 256.
- \overline{CS} goes low until DR goes high to capture the offset and store in offset registers.
- Set cal bit R0[6] = 0.
- To turn on the final filter data with offset, set off_en bit R0[5] = 1.
- To have the final filter data without any offset, set off_en bit R0[5] = 0.

ACPL-0873 works as SPI slave device, and the master device should select clock phase mode CPHA=0 and clock polarity mode CPOL=0. MOSI data is sampled in on the rising edge of SPI clock, MISO data is clocked out at the falling edge of SPI clock.

Thermal Resistance

ACPL-0873 IC (Die) junction temperature is calculated as:

$$T_j = R \times P + T_a$$

Where

R: Junction-to-ambient thermal resistance ($^{\circ}\text{C}/\text{W}$).

P: Power dissipation of IC (W).

T_j: Junction temperature of IC

T_a: Ambient temperature.

The IC was mounted on a low conductivity test board. The board measures 76.2 mm × 76.2 mm as per JEDEC standards. In total, two low-conductivity boards were prepared for the measurement. These test boards are made of FR-4 material and thickness of the copper traces as per JEDEC standards for low conductivity board. Tested “good” devices were used on all the boards. The thermal resistance measurement data is R = 74 $^{\circ}\text{C}/\text{W}$.

Appendices

Table 3: Digital Filter Typical Conversion Time

Filter (Sinc ^K)	Decimation Ratio (D)	Filter Conversion Time t _C at 10-MHz MCLK (1/t _C)
SINC ²	1024	205 μs (4.88 kHz)
SINC ²	512	102 μs (9.76 kHz)
SINC ²	256	51 μs (19.52 kHz)
SINC ²	128	25 μs (39.04 kHz)
SINC ³	256	77 μs (13.02 kHz)
SINC ³	128	38 μs (26.04 kHz)
SINC ³	64	19 μs (52.08 kHz)

NOTE: t_C is calculated as: $t_C = 1 / f_{\text{MCLK}} \times D \times K$.

Table 4: SPI Typical Timing

SPI Clock (MHz)	Time for 8 Bits Write (μs)	Time for 8 Bits Write and 8 Bits Read (μs)	Time for 48 Bits Read (μs)
5	1.60	3.20	9.6
10	0.80	1.60	4.8
15	0.53	1.06	3.18
17	0.47	0.94	2.82

Disclaimer

Only those Broadcom Inc. components that Broadcom has specifically designated as military grade or space grade are intended for use in military/aerospace applications or environments. The user acknowledges and agrees that any military or aerospace use of Broadcom components that have not been so designated is solely at the user's risk, and that the user is solely responsible for compliance with all legal and regulatory requirements in connection with such use.

Broadcom, the pulse logo, Connecting everything, Avago Technologies, Avago, and the A logo are among the trademarks of Broadcom and/or its affiliates in the United States, certain other countries and/or the EU.

Copyright © 2018-2019 Broadcom. All Rights Reserved.

The term "Broadcom" refers to Broadcom Inc. and/or its subsidiaries. For more information, please visit www.broadcom.com.

Broadcom reserves the right to make changes without further notice to any products or data herein to improve reliability, function, or design. Information furnished by Broadcom is believed to be accurate and reliable. However, Broadcom does not assume any liability arising out of the application or use of this information, nor the application or use of any product or circuit described herein, neither does it convey any license under its patent rights nor the rights of others.

