

TSL13FN

Light-to-Voltage Converters

General Description

The TSL13FN is a cost optimized, highly integrated light-to-voltage optical sensor that contains a photodiode and a transimpedance amplifier with a 20 M Ω feedback resistor on a single monolithic integrated circuit. The photodiode active area is 0.5mm x 0.5mm and the sensor responds to visible light in the range of 300 nm to 1100 nm. The output voltage is linear with light intensity (irradiance) incident on the sensor over a wide dynamic range. These devices are supplied in a surface mountable package.

Ordering Information and Content Guide appear at end of datasheet.

Key Benefits & Features

The benefits and features of TSL13FN are listed below:

Figure 1:
Added Value of Using TSL13FN

Benefits	Features
Approximates Human Eye Response	Single Diode
High Irradiance Responsivity to Green	18.7 mV/(μ W/cm ²) at $\lambda_p = 525$ nm
Low Supply Current	0.8mA Typical

Block Diagram

The functional blocks of this device for reference are shown below:

Figure 2:
TSL13FN Block Diagram

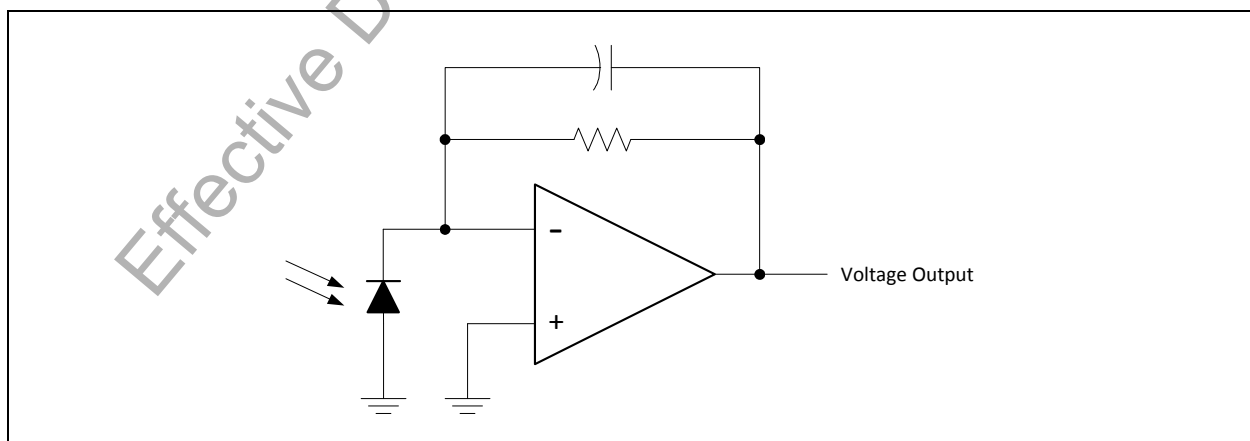

Pin Assignment

Figure 3:
Pin Diagram (Top View)

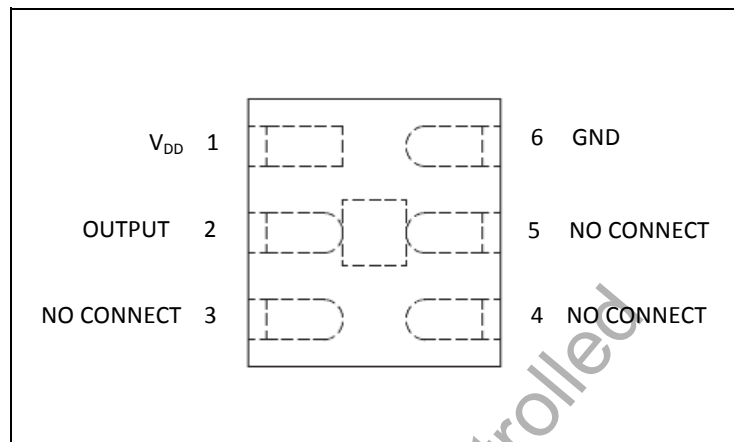

Pin Description

Figure 4:
Pin Description

Pin Number	Pin Name	Description
1	V _{DD}	Supply voltage
2	OUT	Output voltage
3	N/C	No connection
4	N/C	No connection
5	N/C	No connection
6	GND	Power supply ground. All voltages are referenced to GND

Effective Document - Printout not Controlled

Absolute Maximum Ratings

Stresses beyond those listed under “Absolute Maximum Ratings” may cause permanent damage to the device. These are stress ratings only. Functional operation of the device at these or any other conditions beyond those indicated under “Operating Conditions” is not implied. Exposure to absolute maximum rating conditions for extended periods may affect device reliability.

Figure 5:
Absolute Maximum Ratings

Symbol	Parameter	Min	Max	Units	Comments
V_{DD}	Supply voltage		6	V	All voltages are with respect to GND
I_O	Output current	-10	10	mA	
T_{stg}	Storage temperature range	-40	85	°C	

Effective Document - Printout not Controlled

Electrical Characteristics

All limits are guaranteed. The parameters with min and max values are guaranteed with production tests or SQC (Statistical Quality Control) methods.

Figure 6:
Recommended Operating Conditions

Symbol	Parameter	Min	Typ	Max	Units
V_{DD}	Supply voltage	2.7		5.5	V
T_A	Operating free-air temperature	-30		70	°C

Figure 7:
Operating Characteristics, $V_{DD} = 5\text{ V}$, $T_A = 25^\circ\text{C}$, $\lambda_p = 525\text{ nm}$ (unless otherwise noted) ^{(1), (2), (3)}

Symbol	Parameter	Conditions	Min	Typ	Max	Units
V_{OM}	Maximum output voltage		4.6	4.9		V
V_O	Output voltage	$\lambda_p = 525\text{ nm}$ $E_e = 107\ \mu\text{W}/\text{cm}^2$	1.5	2	2.5	V
		$\lambda_p = 850\text{ nm}$ $E_e = 70.5\ \mu\text{W}/\text{cm}^2$	1.5	2	2.5	
R_e	Irradiance responsivity	$\lambda_p = 525\text{ nm}$ ⁽⁴⁾		18.7		$\text{mV}/(\mu\text{W}/\text{cm}^2)$
V_{OS}	Extrapolated offset voltage	see note (4)	-0.02	0.03	0.08	V
V_d	Dark voltage	$E_e = 0\ \mu\text{W}/\text{cm}^2$	0		0.08	V
I_D	Supply current	$\lambda_p = 525\text{ nm}$ $E_e = 107\ \mu\text{W}/\text{cm}^2$		0.8	1.3	mA

Note(s) and/or Footnote(s):

- Optical measurements are made using small-angle incident radiation from an LED optical source.
- The 525 nm irradiance E_e is supplied by a InGaN light-emitting diode with the following typical characteristics: peak wavelength $\lambda_p = 525\text{ nm}$ and spectral halfwidth $\Delta\lambda_{1/2} = 40\text{ nm}$.
- The 850 nm irradiance E_e is supplied by a light-emitting diode with the following typical characteristics: peak wavelength $\lambda_p = 850\text{ nm}$ and spectral halfwidth $\Delta\lambda_{1/2} = 42\text{ nm}$.
- Irradiance responsivity is characterized over the range $V_O = 0.2$ to 4 V . The best-fit straight line of output voltage V_O versus irradiance E_e over this range may have a positive or negative extrapolated V_O value for $E_e = 0$. For low irradiance values, the output voltage V_O versus irradiance E_e characteristic is nonlinear with a deviation toward $V_O = 0$, $E_e = 0$ origin from the best-fit straight line referenced above.

Figure 8:
Dynamic Characteristics, $V_{DD} = 5\text{ V}$, $T_A = 25^\circ\text{C}$, $\lambda_p = 525\text{ nm}$, $R_L = 10\text{ k}\Omega$ (unless otherwise noted)
 (see also Figure 9)

Symbol	Parameter	Conditions	Min	Typ	Max	Units
t_{dr}	Output pulse delay time for rising edge (0% to 10%)	Min $V_O = 0\text{V}$; Peak $V_O = 2\text{V}$ Min $V_O = 0.5\text{V}$; Peak $V_O = 2\text{V}$		1.7 1.2		μs
t_r	Output pulse rise time (10% to 90%)	Min $V_O = 0\text{V}$; Peak $V_O = 2\text{V}$ Min $V_O = 0.5\text{V}$; Peak $V_O = 2\text{V}$		7.2 6.5		μs
t_{df}	Output pulse delay time for falling edge (100% to 90%)	Min $V_O = 0\text{V}$; Peak $V_O = 2\text{V}$ Min $V_O = 0.5\text{V}$; Peak $V_O = 2\text{V}$		1.2 1.1		μs
t_f	Output pulse fall time (90% to 10%)	Min $V_O = 0\text{V}$; Peak $V_O = 2\text{V}$ Min $V_O = 0.5\text{V}$; Peak $V_O = 2\text{V}$		6.8 6.4		μs

Timing Diagrams

Figure 9:
Parameter Measurement Information

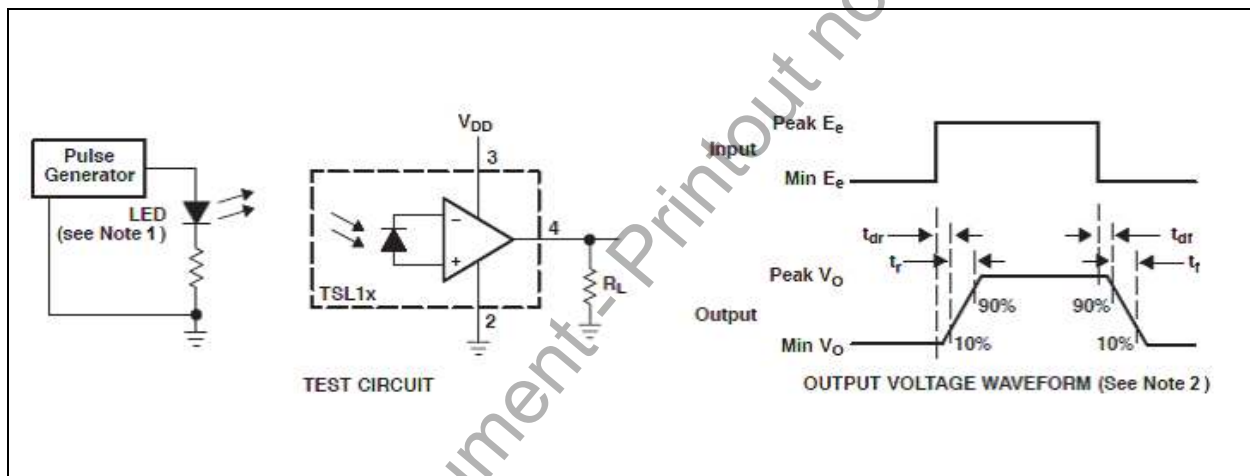

Note(s) and/or Footnote(s):

1. The input irradiance is supplied by a pulsed InGaN light emitting diode with the following characteristics: $\lambda_p = 525\text{ nm}$, $t_r < 1\ \mu\text{s}$, $t_f < 1\ \mu\text{s}$.
2. The output waveform is monitored on an oscilloscope with the following characteristics: $t_r < 100\text{ ns}$, $Z_i \geq 1\ \text{M}\Omega$, $C_i \leq 20\ \text{pF}$.

Typical Operating Characteristics

Figure 10:
Spectral Responsivity

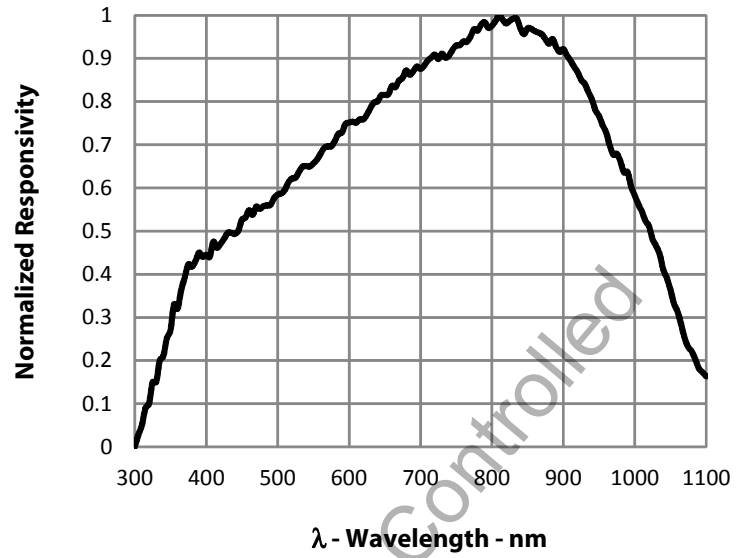

Figure 11:
Normalized Output Voltage vs. Angular Response

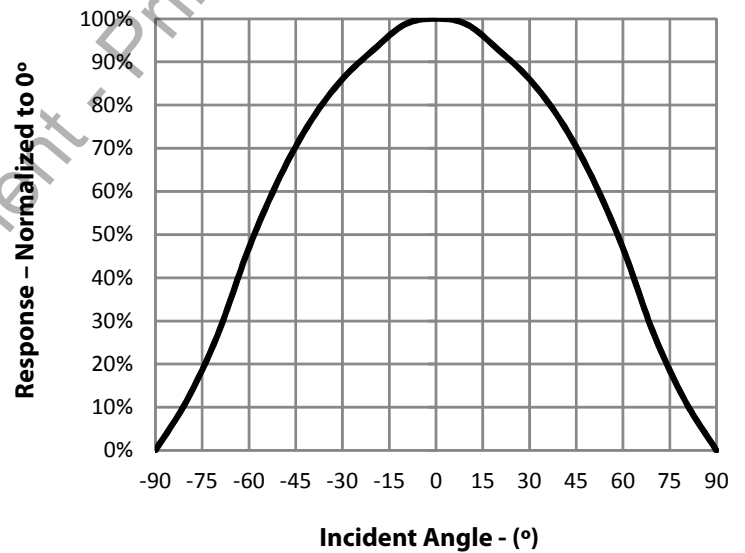

Figure 12:
Rising Edge Dynamic Characteristics vs. Peak Output Voltage (Min $V_o = 0V$)

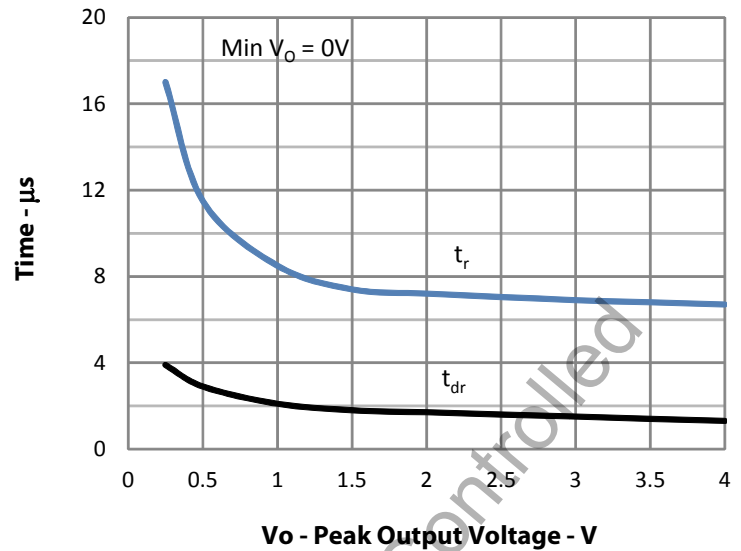
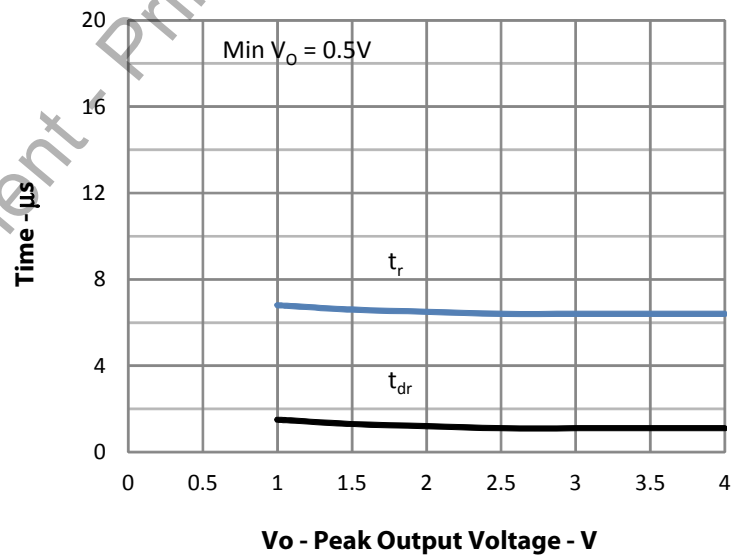

Figure 13:
Rising Edge Dynamic Characteristics vs. Peak Output Voltage (Min $V_o = 0.5V$)



Effective Document - Printout not Controlled

Figure 14:
Falling Edge Dynamic Characteristics vs. Peak Output Voltage (Min $V_o = 0V$)

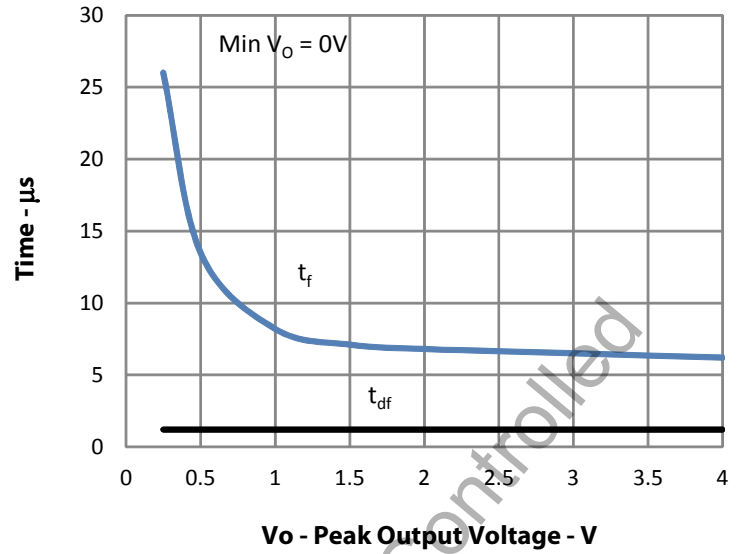
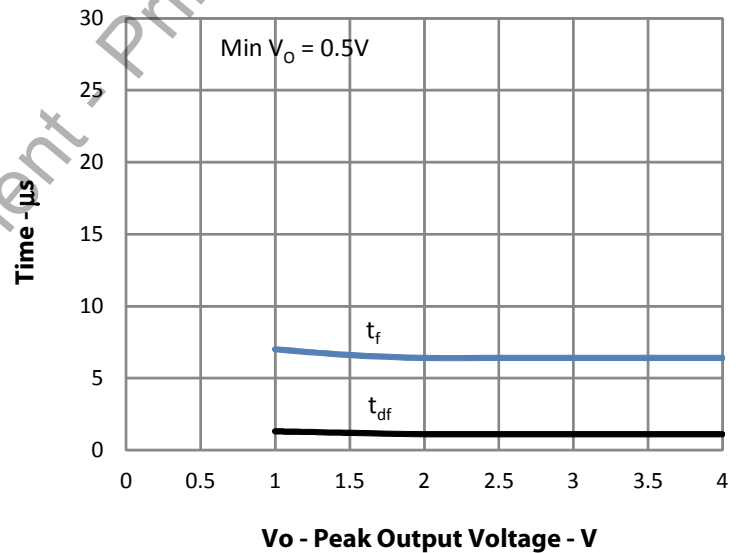

Figure 15:
Falling Edge Dynamic Characteristics vs. Peak Output Voltage (Min $V_o = 0.5V$)



Effective Document, Printout not Controlled

PCB Pad Layout

Figure 16:
Suggested FN Package PCB Layout

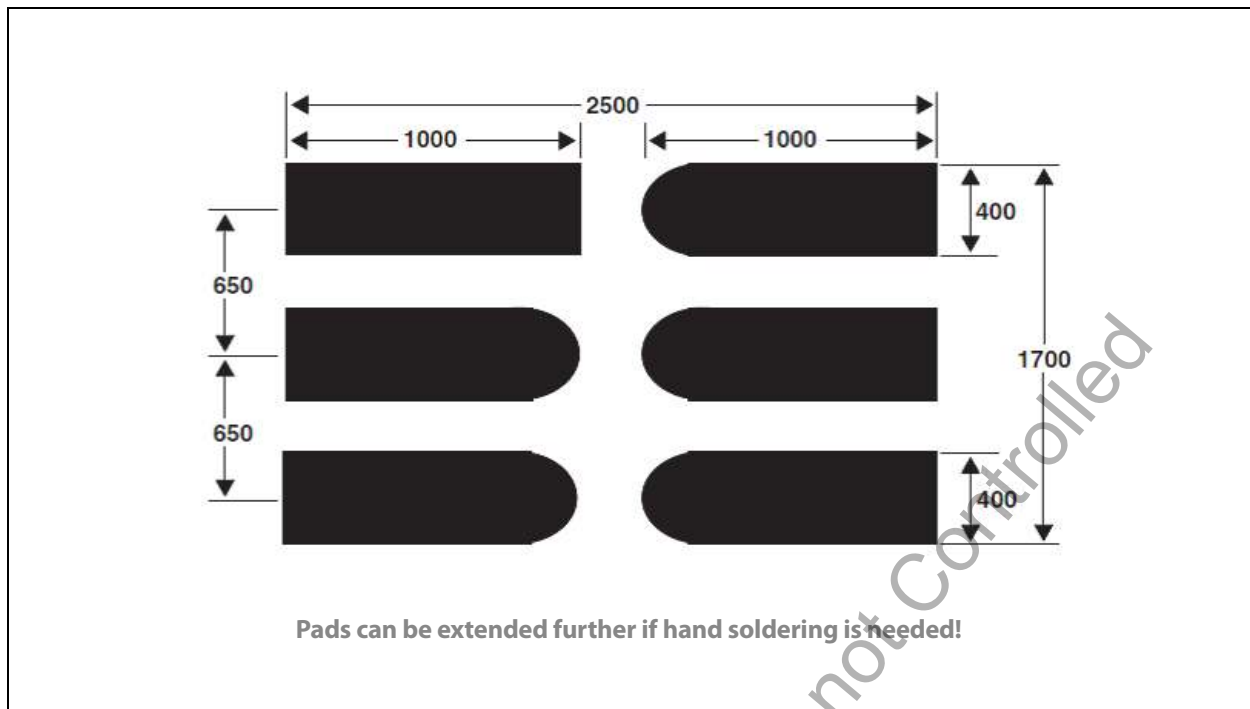

Note(s) and/or Footnote(s):

1. All linear dimensions are in millimeters.
2. This drawing is subject to change without notice.

Effective Document - Printout not Controlled

Package Drawings & Markings

Figure 17:
Six-lead Surface Mount FN Package Configuration

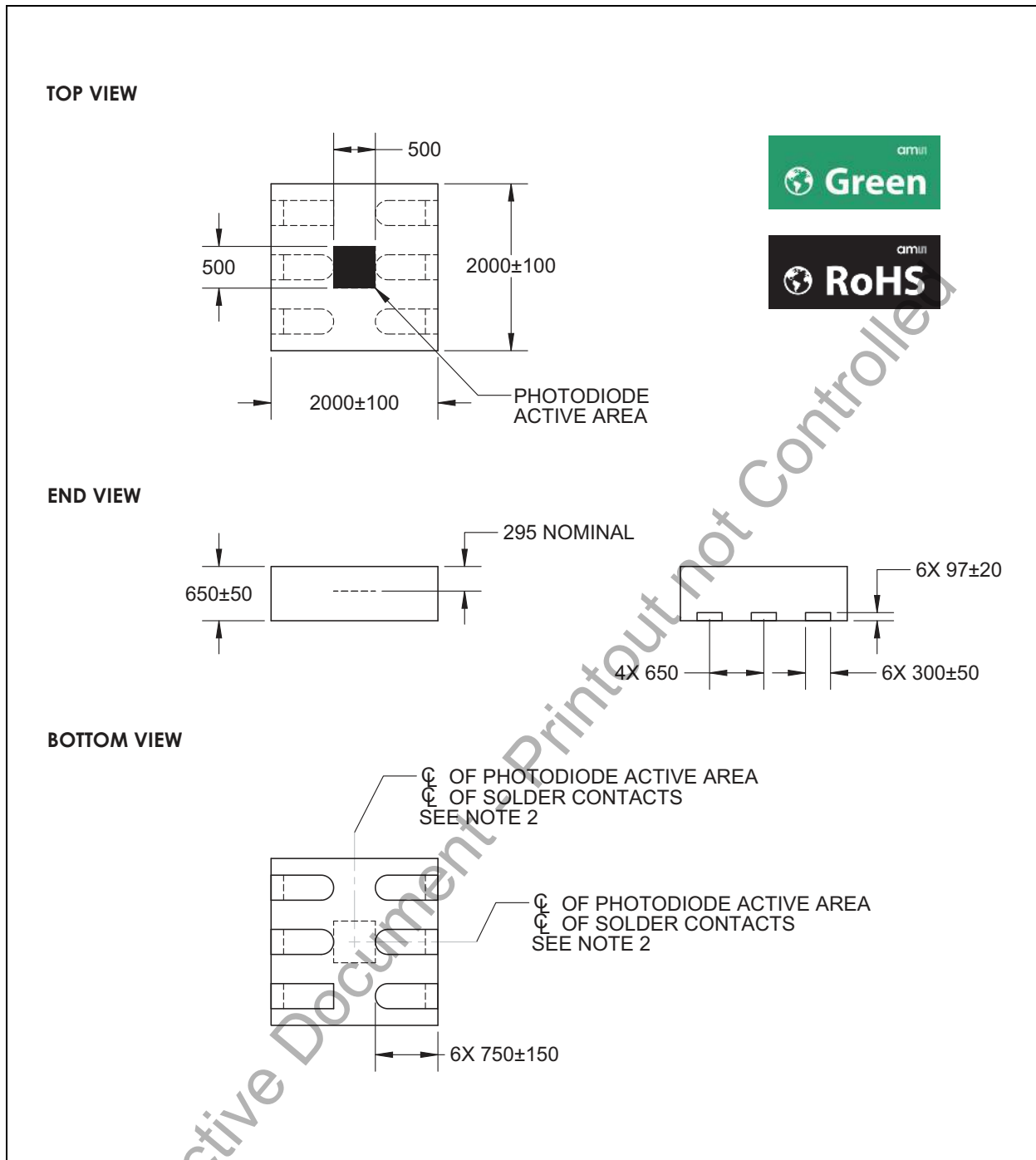

Note(s) and/or Footnote(s):

1. All linear dimensions are in micrometers.
2. The Photodiode Active Area is centered within the package within a tolerance of ± 75 micrometers.
3. Package top surface is molded with an electrically nonconductive clear plastic compound having an index of refraction of 1.55.
4. Contact finish is Copper Alloy A194 with pre-plated NiPdAu lead finish.
5. This package contains no lead (Pb).
6. This drawing is subject to change without notice.

Soldering & Storage Information

Soldering Information

The reflow profile specified here describes expected maximum heat exposure of devices during the solder reflow process of the device on a PCB. Temperature is measured at the top of the device. Devices should be limited to one pass through solder reflow profile.

Figure 19:
Solder Reflow Profile

Symbol	Parameter	TSL13FN
	Average temperature gradient in preheating	2.5°C/sec
t_{soak}	Soak time	2 to 3 minutes
t_1	Time above T_1 , 217°C	Max 60 sec
t_2	Time above T_2 , 230°C	Max 50 sec
t_3	Time above T_3 , ($T_{\text{peak}} - 10^\circ\text{C}$)	Max 10 sec
T_{peak}	Peak temperature in reflow	260°C(-0°C/+5°C)
	Temperature gradient in cooling	Max -5°C/sec

Figure 20:
Solder Reflow Graph

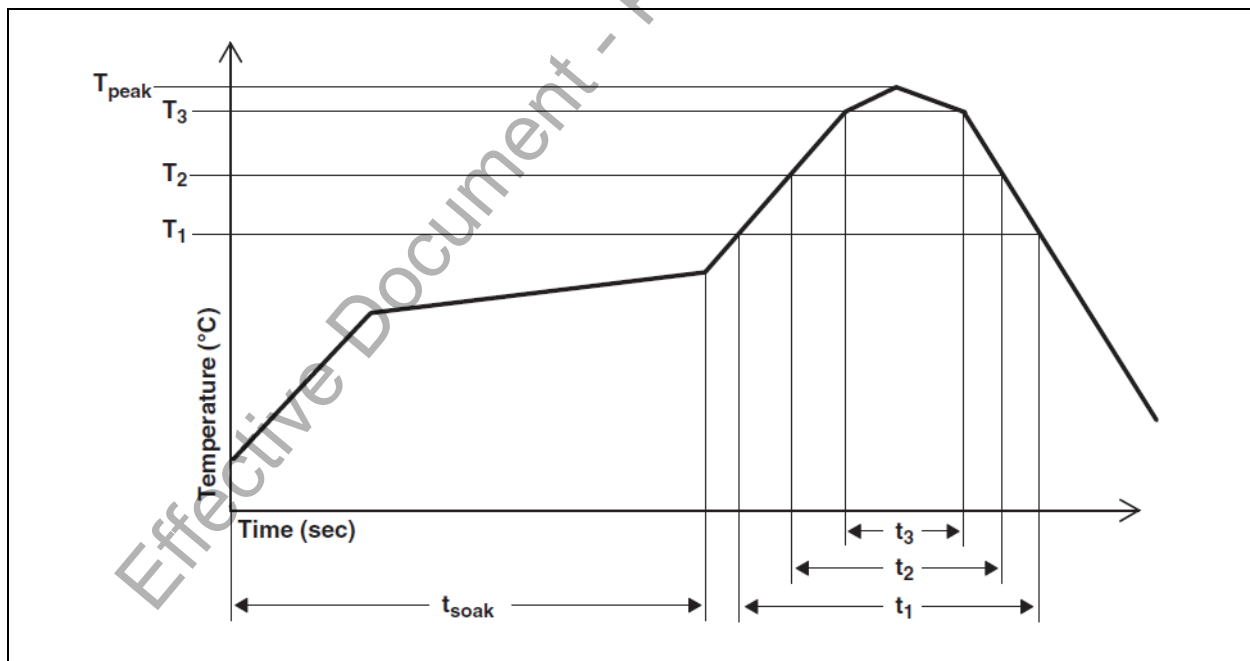

Note: Not to scale – for reference only.

Storage Information

Moisture Sensitivity

Optical characteristics of the device can be adversely affected during the soldering process by the release and vaporization of moisture that has been previously absorbed into the package. To ensure the package contains the smallest amount of absorbed moisture possible, each device is baked prior to being dry packed for shipping.

Devices are dry packed in a sealed aluminized envelope called a moisture-barrier bag with silica gel to protect them from ambient moisture during shipping, handling, and storage before use.

This package has been assigned a moisture sensitivity level of MSL3 and the devices should be stored under the following conditions.

- Temperature Range: 5°C to 50°C
- Relative Humidity: 60% maximum
- Total Time: 12 months from the date code on the aluminized envelope – if opened
- Open Time: 168 hours or less

Re-baking will be required if the devices have been stored unopened for more than 12 months or the aluminized envelope has been open for more than 168hrs. If re-baking is required, it should be done at 50°C for 12 hours.

Effective Document - Printout not controlled

Ordering & Contact Information

Figure 21:
Ordering Information

Device	T _A	Package Description	Package Designator	Ordering Number
TSL13	0 to 70°C	6-lead Surface Mount	FN	TSL13FN

Buy our products or get free samples online at:
www.ams.com/ICdirect

Technical Support is available at:
www.ams.com/Technical-Support

For further information and requests, e-mail us at:
ams_sales@ams.com

For sales offices, distributors and representatives, please visit:
www.ams.com/contact

Headquarters

ams AG
Tobelbaderstrasse 30
8141 Unterpremstaetten
Austria, Europe

Tel: +43 (0) 3136 500 0

Website: www.ams.com

Effective Document - Printout not Controlled

RoHS Compliant & ams Green Statement

RoHS: The term RoHS compliant means that ams AG products fully comply with current RoHS directives. Our semiconductor products do not contain any chemicals for all 6 substance categories, including the requirement that lead not exceed 0.1% by weight in homogeneous materials. Where designed to be soldered at high temperatures, RoHS compliant products are suitable for use in specified lead-free processes.

ams Green (RoHS compliant and no Sb/Br): ams Green defines that in addition to RoHS compliance, our products are free of Bromine (Br) and Antimony (Sb) based flame retardants (Br or Sb do not exceed 0.1% by weight in homogeneous material).

Important Information: The information provided in this statement represents ams AG knowledge and belief as of the date that it is provided. ams AG bases its knowledge and belief on information provided by third parties, and makes no representation or warranty as to the accuracy of such information. Efforts are underway to better integrate information from third parties. ams AG has taken and continues to take reasonable steps to provide representative and accurate information but may not have conducted destructive testing or chemical analysis on incoming materials and chemicals. ams AG and ams AG suppliers consider certain information to be proprietary, and thus CAS numbers and other limited information may not be available for release.

Effective Document - Printout not Controlled

Copyrights & Disclaimer

Copyright ams AG, Tobelbader Strasse 30, 8141 Unterpremstaetten, Austria-Europe. Trademarks Registered. All rights reserved. The material herein may not be reproduced, adapted, merged, translated, stored, or used without the prior written consent of the copyright owner.

Devices sold by ams AG are covered by the warranty and patent indemnification provisions appearing in its General Terms of Trade. ams AG makes no warranty, express, statutory, implied, or by description regarding the information set forth herein. ams AG reserves the right to change specifications and prices at any time and without notice. Therefore, prior to designing this product into a system, it is necessary to check with ams AG for current information. This product is intended for use in commercial applications. Applications requiring extended temperature range, unusual environmental requirements, or high reliability applications, such as military, medical life-support or life-sustaining equipment are specifically not recommended without additional processing by ams AG for each application. This product is provided by ams AG "AS IS" and any express or implied warranties, including, but not limited to the implied warranties of merchantability and fitness for a particular purpose are disclaimed.

ams AG shall not be liable to recipient or any third party for any damages, including but not limited to personal injury, property damage, loss of profits, loss of use, interruption of business or indirect, special, incidental or consequential damages, of any kind, in connection with or arising out of the furnishing, performance or use of the technical data herein. No obligation or liability to recipient or any third party shall arise or flow out of ams AG rendering of technical or other services.

Effective Document - Printout Not for Circulation

Document Status

Document Status	Product Status	Definition
Product Preview	Pre-Development	Information in this datasheet is based on product ideas in the planning phase of development. All specifications are design goals without any warranty and are subject to change without notice
Preliminary Datasheet	Pre-Production	Information in this datasheet is based on products in the design, validation or qualification phase of development. The performance and parameters shown in this document are preliminary without any warranty and are subject to change without notice
Datasheet	Production	Information in this datasheet is based on products in ramp-up to full production or full production which conform to specifications in accordance with the terms of ams AG standard warranty as given in the General Terms of Trade
Datasheet (discontinued)	Discontinued	Information in this datasheet is based on products which conform to specifications in accordance with the terms of ams AG standard warranty as given in the General Terms of Trade, but these products have been superseded and should not be used for new designs

Effective Document - Printout Not Controlled

Revision Information

Changes from 0-03 (2013-Nov) to current revision 1-00 (2014-Jun-04)	Page
Content was updated to the latest ams design	

Effective Document - Printout not Controlled

Content Guide

- 1 General Description**
 - 1 Key Benefits & Features
 - 1 Block Diagram

- 2 Pin Assignment**
- 2 Pin Description**
- 3 Absolute Maximum Ratings**

- 4 Electrical Characteristics**
 - 5 Timing Diagrams

- 6 Typical Operating Characteristics**
- 9 PCB Pad Layout**
- 10 Package Drawings & Markings**
- 11 Mechanical Data**

- 12 Soldering & Storage Information**
 - 12 Soldering Information
 - 13 Storage Information
 - 13 Moisture Sensitivity

- 14 Ordering & Contact Information**
- 15 RoHS Compliant & ams Green Statement**
- 16 Copyrights & Disclaimer**
- 17 Document Status**
- 18 Revision Information**

Effective Document - Printout not Controlled