

REVISIONS					
REV	ECO	DESCRIPTION	DATE	BY	APPR
A3	-	RELEASE NEW DWG FORMAT	10/21/13	DRP	-
A4	-	REVISED PLATING INFO	16/JUN/16	JAH	-
A5	C1070S	UPDATE DRAWING	28/JUN/19	JOE	TOMMY
B1	C1298S	UPDATE PLATING	14/SEP/20	SULLEN	TOMMY

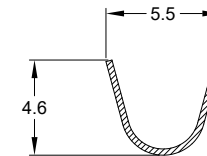

SECTION A-A

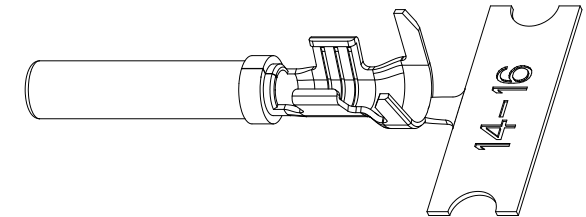
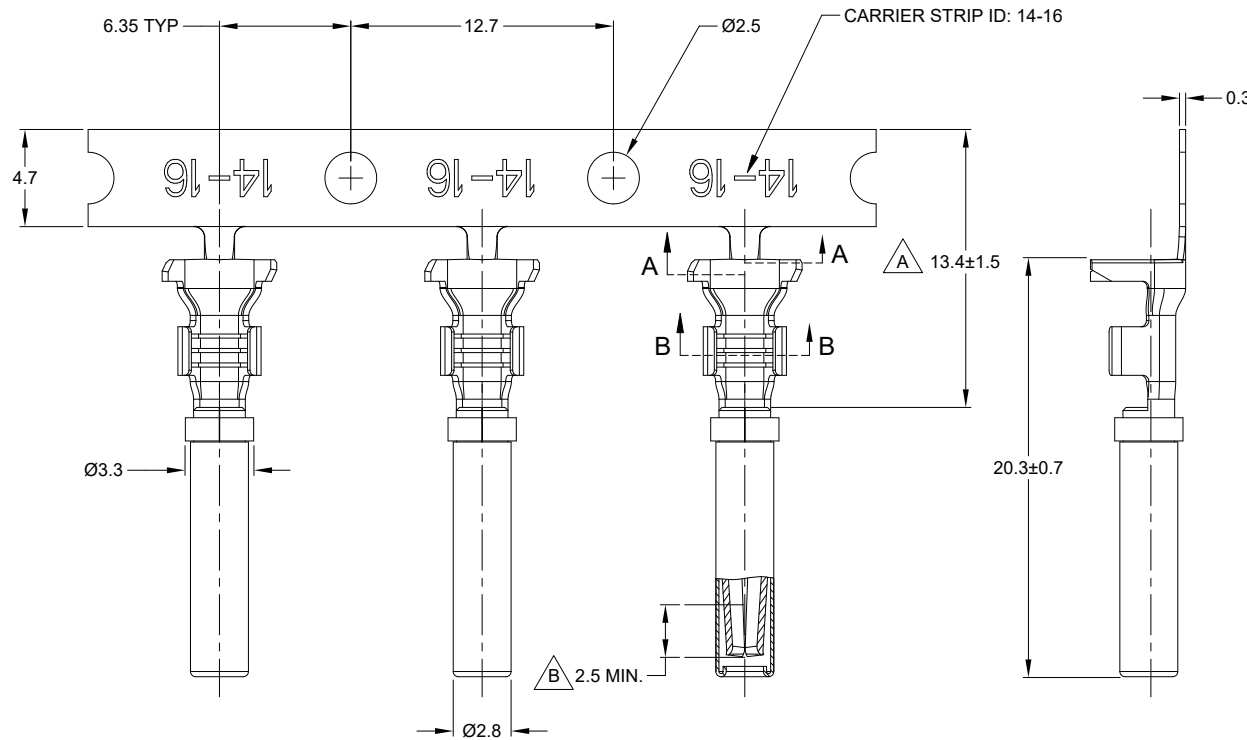
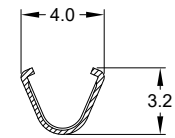

SECTION B-B

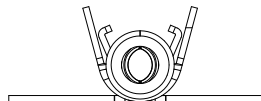

NOTES: UNLESS OTHERWISE SPECIFIED

- MATERIAL: COPPER ALLOY
- PLATING: SEE PART NUMBER CHART
- CONTACT SIZE: 16
- SPECIFICATIONS:
  - CURRENT RATING: 13 AMPS
  - CONTACT MILLIVOLT DROP: 100 MILLIVOLT DROP @ 13 AMP TEST CURRENT.
  - RoHS COMPLIANT
- RECOMMENDED WIRE RANGE: 14 - 16 AWG (2.0 - 1.5mm<sup>2</sup>)  
RECOMMENDED INSUL O.D: 2.40 - 3.81MM (0.094 - 0.151INCH)
- PACKAGE: 4000 PCS/REEL
- AVAILABLE APPLICATORS: MFX-3975-K OR MFX-3975-G
- ALL DIMENSIONS ARE FOR REFERENCE USE ONLY

PART NUMBER CHART		
PLATING	PART NUMBER	PLATING DESCRIPTION
NICKEL	AT62-14-0122	SELECTIVE TIN OVER NICKEL OVERALL IN $\Delta$ ZONE
GOLD	AT62-14-0144	SELECTIVE GOLD FLASH OVER NICKEL OVERALL IN $\Delta$ ZONE OR ENTIRE CONTACT
TIN	AT62-14-0177	TIN OVER NICKEL OVERALL

SEE PART NUMBER CHART		REF: 1062-14-0122, 1062-14-0144		
PART NUMBER		DESCRIPTION		
QUANTITY	MATERIALS LIST			ITEM
UNLESS OTHERWISE SPECIFIED 1) All dimensions are in metric (mm). 2) Tolerances are as follows: 1 PL DEC ±0.30 Fractions ±1/64 2 PL DEC ±0.15 Angles ±1° 3 PL DEC ±0.08				
SIGNATURES		DATE		
DRAWN: SULLENZANG		14/SEP/20		
CHECKED: ORIONLI		15/SEP/20		
ENGINEER:		APPROVAL: TOMMY XIE		
MATERIAL SPECIFICATIONS:		18/SEP/20		
PROCESS SPECIFICATIONS:		CUSTOMER:		
NEXT ASSY:		THIS DRAWING IS SUPPLIED FOR INFORMATION ONLY. DESIGN FEATURES, SPECIFICATIONS AND PERFORMANCE DATA SHOWN HEREON ARE THE PROPERTY OF THE AMPHENOL CORPORATION. NO RIGHTS OF REPRODUCTION ARE IMPLIED. ALL DIMENSIONS ARE SUBJECT TO NORMAL MANUFACTURING VARIATIONS.		
SCALE: NONE		SIZE: B C-	DWG NO: AT62-14-01XX	REVISION: B1
		CONTACT, SOCKET, STAMPED, SIZE 16, 14-16 AWG, A SERIES		SHEET 1 OF 1

TITLE: SOCKET, STAMPED, SIZE 16, 14-16 AWG, A SERIES  
 DWG NO: AT62-14-01XX  
 REV: B1  
 SH: 1  
 OF: 1