

PACKAGE DIMENSIONS inch (mm)

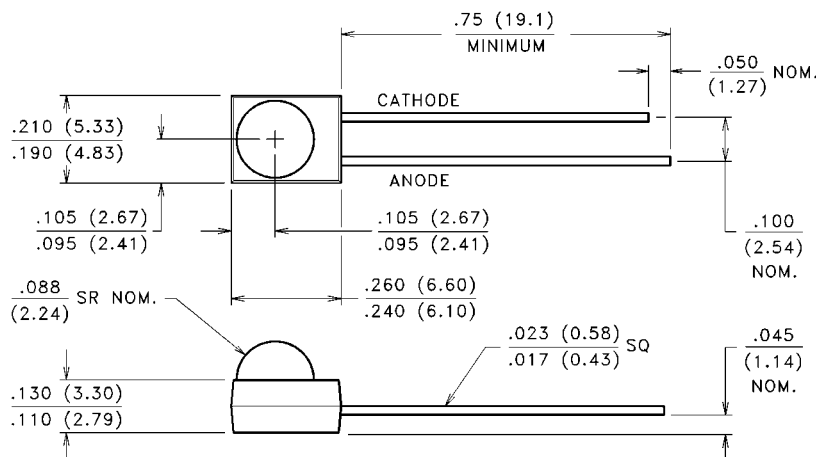

CASE 51 LENSED SIDELOOKER
CHIP ACTIVE AREA: .0082 in² (5.27 mm²)

PRODUCT DESCRIPTION

Planar silicon photodiode in a transfer molded, large lensed sidelooker package. The dark package material filters out visible light but passes infrared. These diodes exhibit low dark current under reverse bias and fast speed of response.

ABSOLUTE MAXIMUM RATINGS

Storage Temperature: -40°C to 85°C
 Operating Temperature: -40°C to 85°C

RoHS Compliant



ELECTRO-OPTICAL CHARACTERISTICS @ 25°C (See also VTP curves, pages 45-46)

SYMBOL	CHARACTERISTIC	TEST CONDITIONS	VTP7840H			UNITS
			Min.	Typ.	Max.	
I _{SC}	Short Circuit Current	H = 100 fc, 2850 K	50	70		μA
TC I _{SC}	I _{SC} Temperature Coefficient	2850 K		.20		%/°C
V _{OC}	Open Circuit Voltage	H = 100 fc, 2850 K		325		mV
TC V _{OC}	V _{OC} Temperature Coefficient	2850 K		-2.0		
I _D	Dark Current	H = 0, V _R = 10 V			20	nA
R _{SH}	Shunt Resistance	H = 0, V = 10 mV		0.25		GΩ
C _J	Junction Capacitance	H = 0, V = 3 V			40	pF
S _R	Sensitivity	@ Peak		.55		A/W
λ _{range}	Spectral Application Range		725		1150	nm
λ _p	Spectral Response - Peak			925		nm
V _{BR}	Forward Voltage	@ 10 mA		1.0		V
θ _{1/2}	Angular Resp. - 50% Resp. Pt.			±48		Degrees
NEP	Noise Equivalent Power			5.3 x 10 ⁻¹⁴ (Typ.)		W/√Hz
D*	Specific Detectivity			5.1 x 10 ¹² (Typ.)		cm√Hz/W