

- NOTES:
- PART SHALL BE FREE OF BURRS AND SHARP EDGES
 - ASSURE ASSEMBLY CAPABILITY BY MATCHING WITH MATING PART
 - DIMENSIONS IN [] ARE IN MILLIMETERS

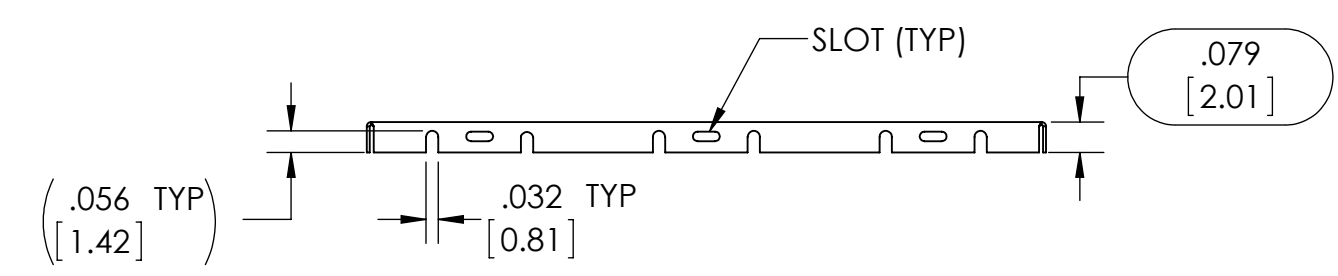

FORMED COVER

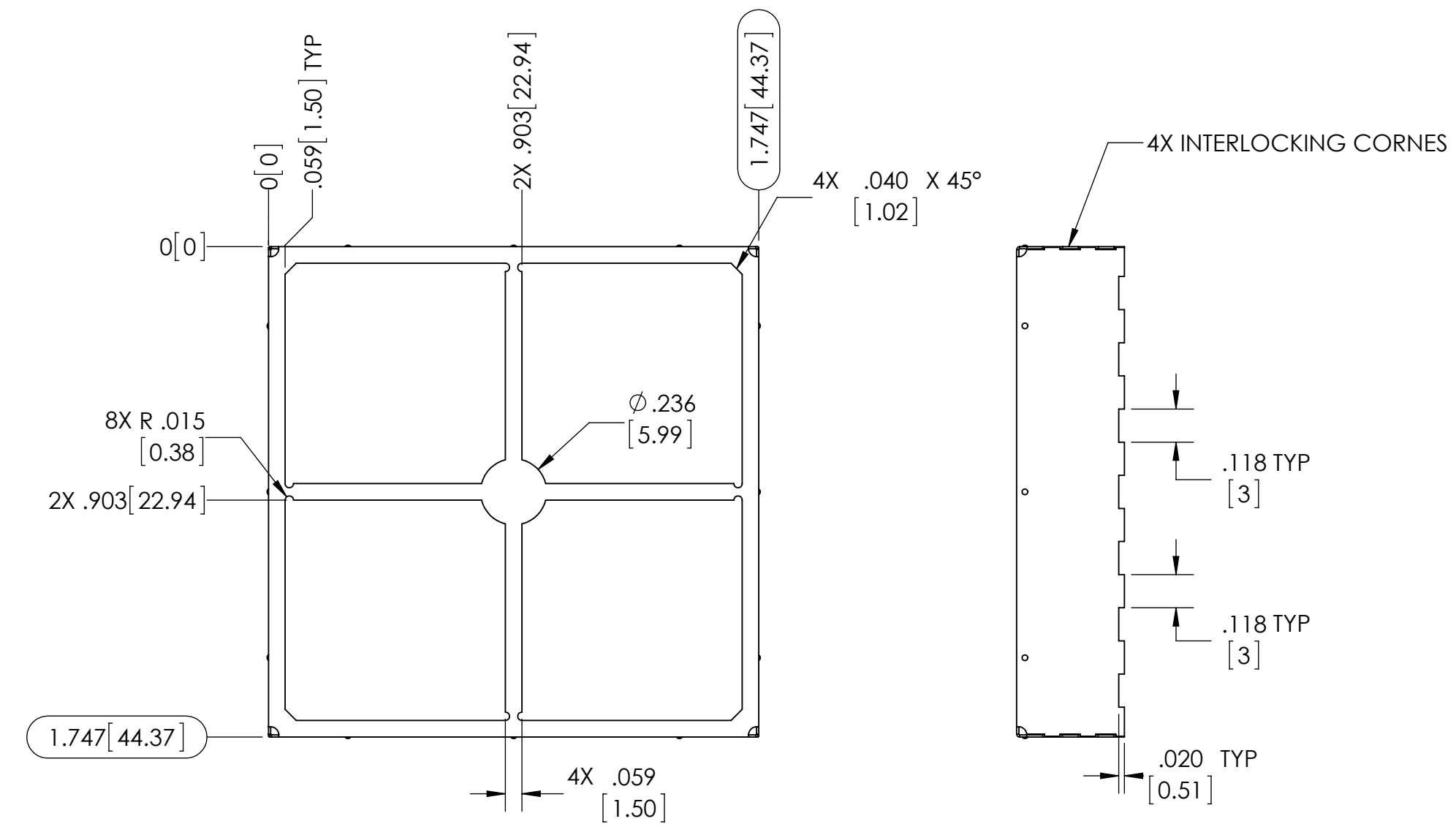
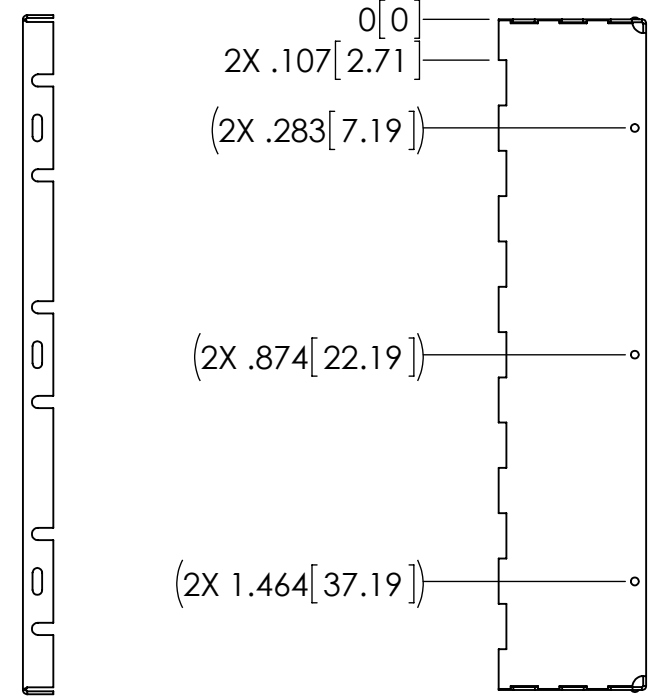
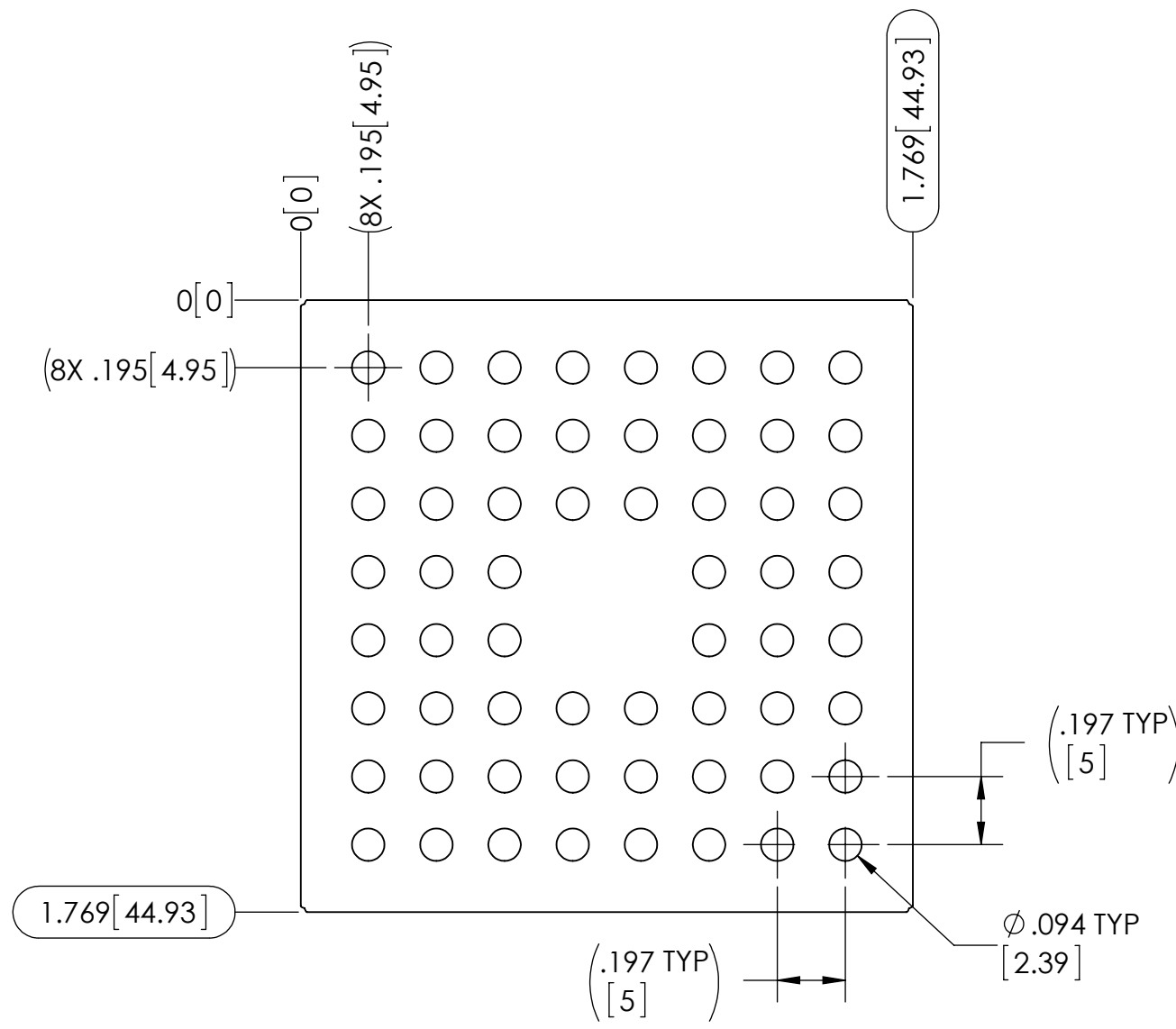
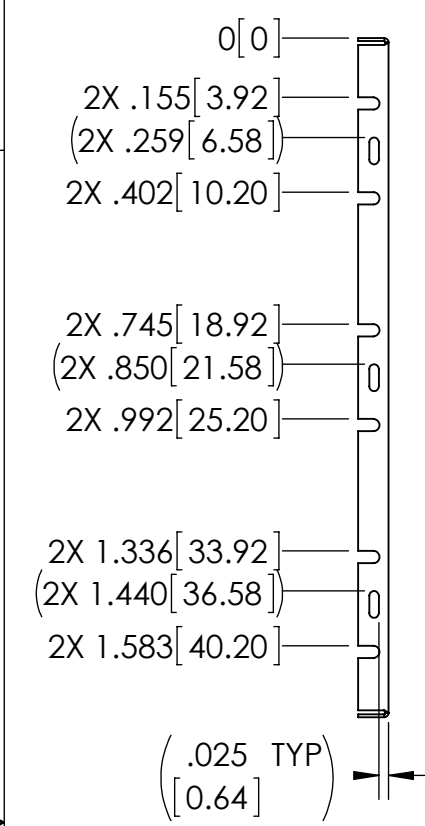
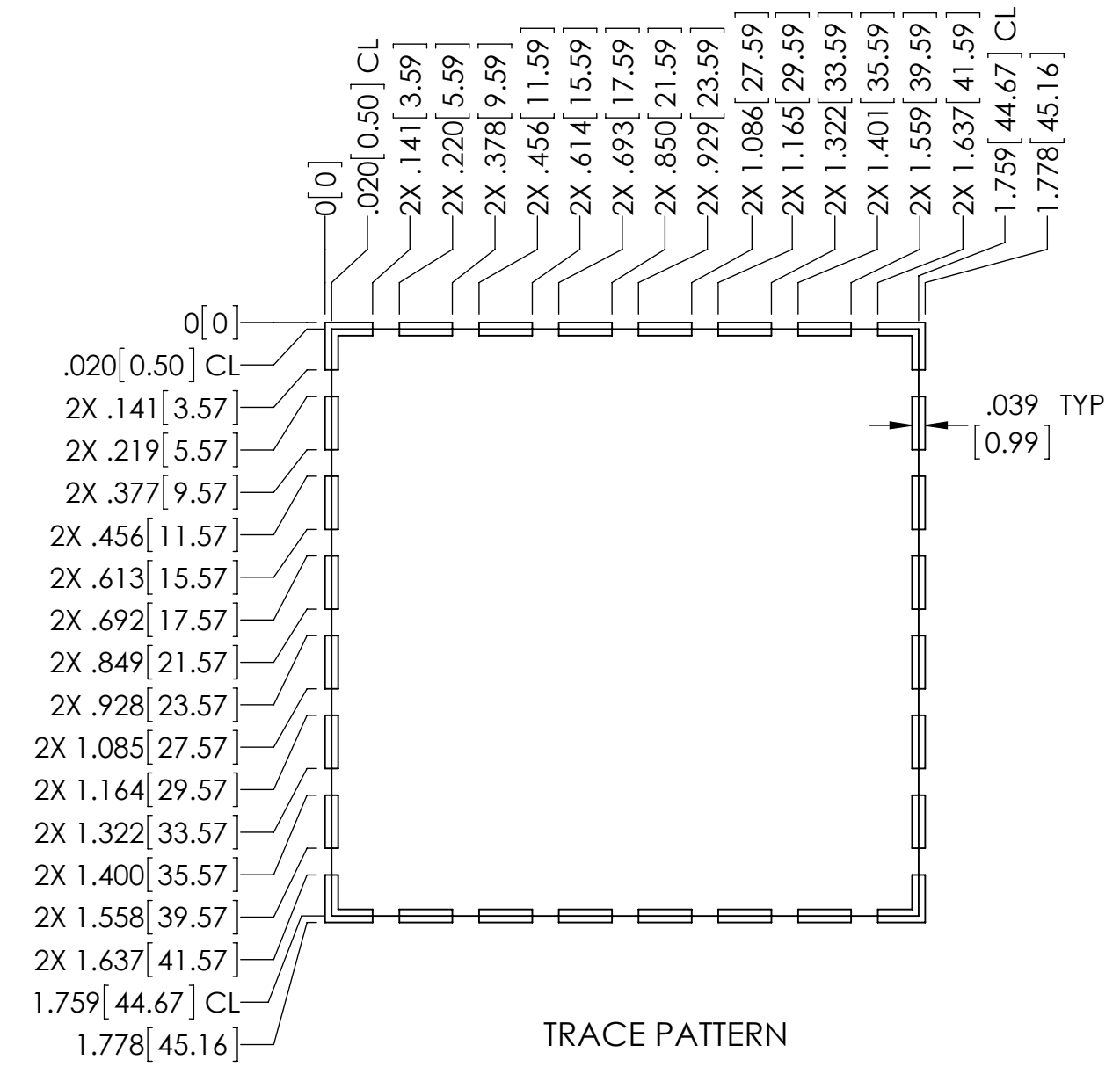
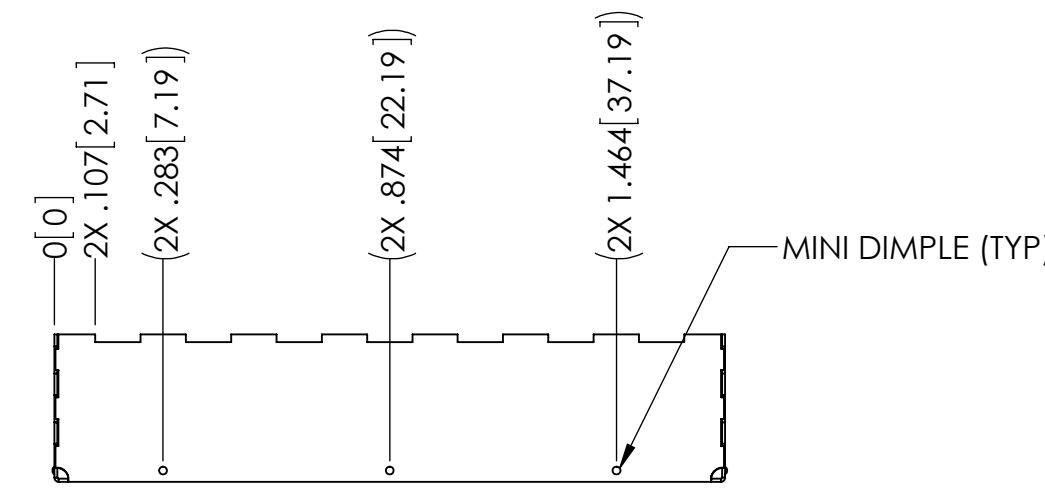
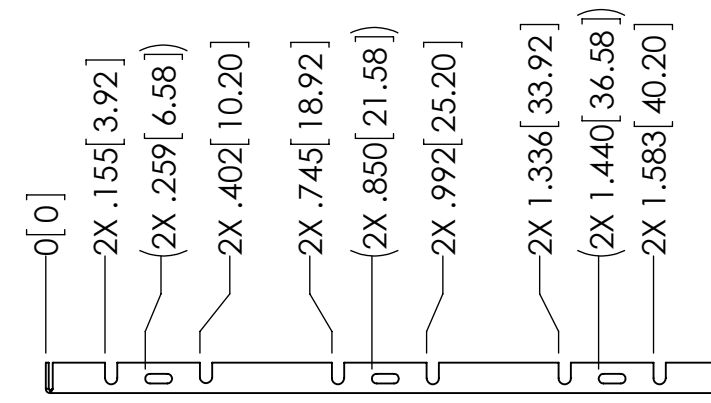
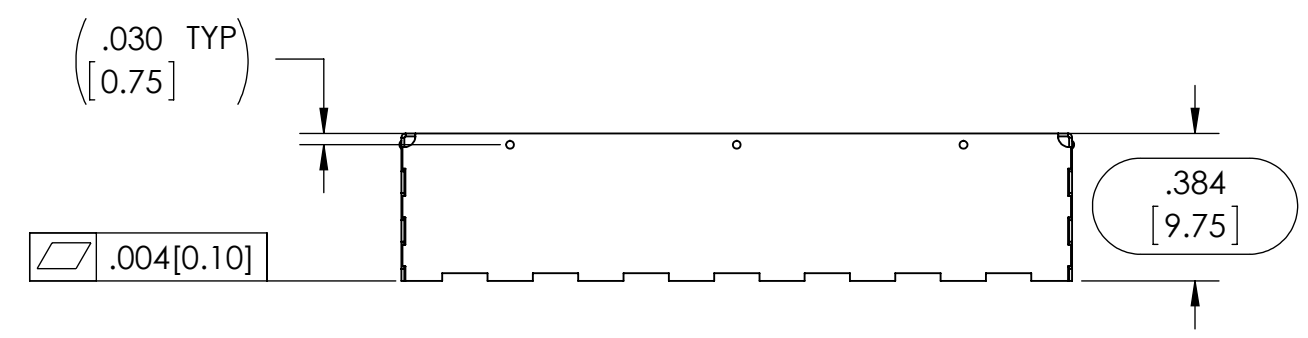

FORMED FRAME

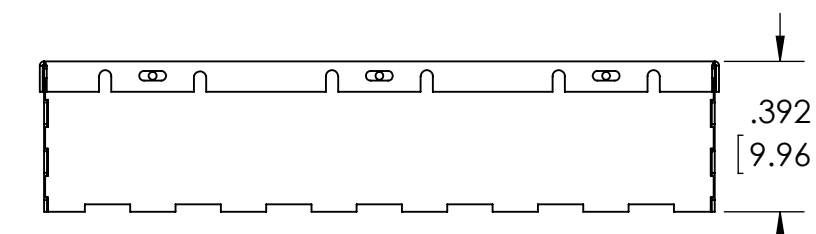
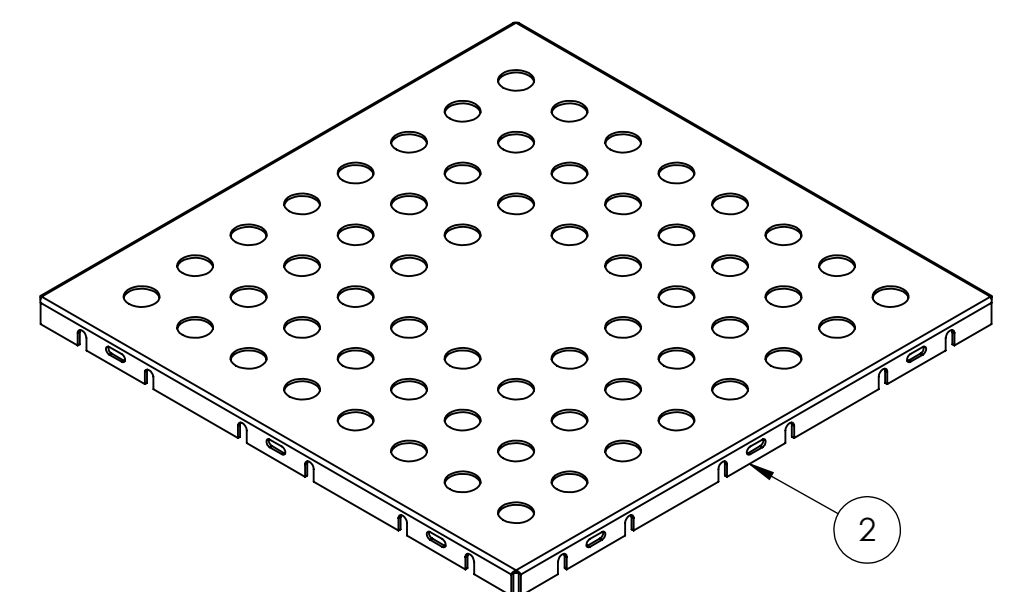

ASSEMBLY

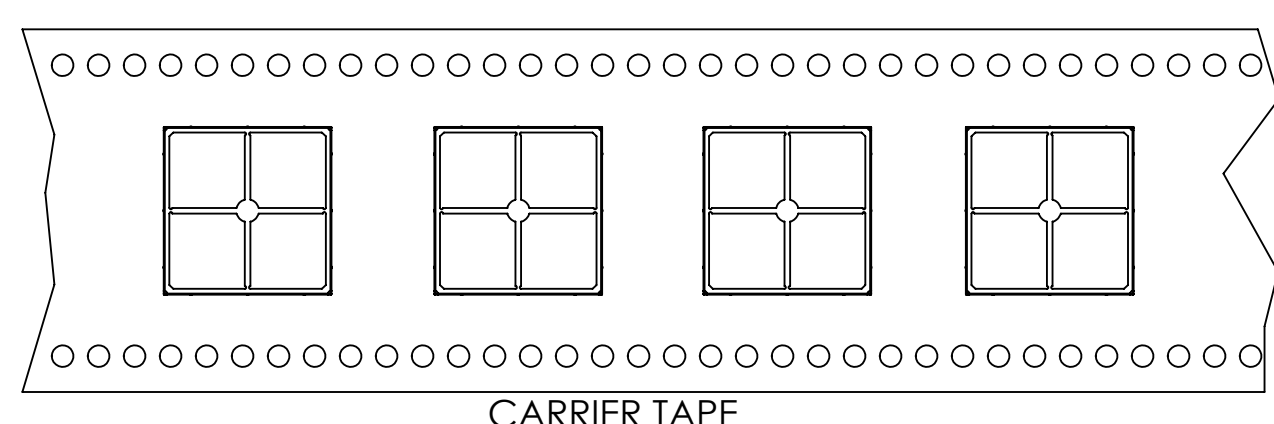

CARRIER TAPE

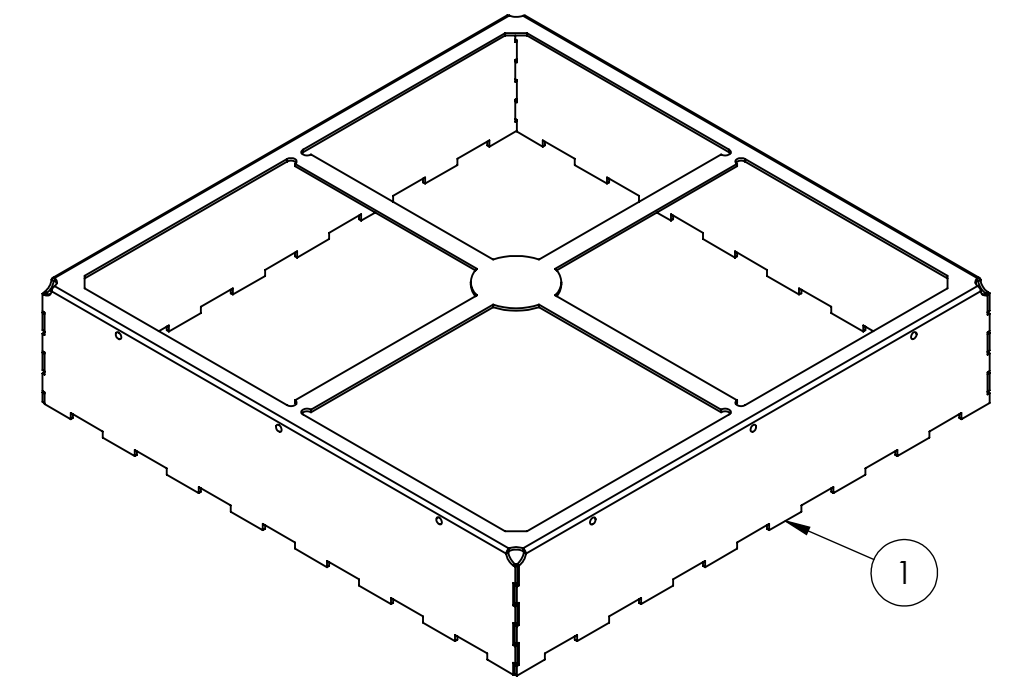

ITEM NO.	PART NUMBER	DESCRIPTION	QTY.
1	SMS-207 F	FRAME	1
2	SMS-207 C	COVER	1

UNLESS OTHERWISE SPECIFIED:
 - ALL DIMENSIONS ARE IN INCHES
 - PART SHALL BE FREE OF BURRS AND SHARP EDGES
 - ALL DIMENSIONS SHOWN APPLY BEFORE PLATING AND COATINGS
 - ROHS COMPLIANT PER EU DIRECTIVE 2011/65/EU
 - POI = POINT OF INTERSECTION

THIRD ANGLE PROJECTION

SCALE: 2:1

DATE: 7/28/2009

APPROVED BY: GS

DATE: 8/13/2009

MATERIAL: .008[0.20] PRE TIN STEEL

SIZE: D

DWG. NO.: SMS-207

REV: D

CAGE CODE: 41674

SHEET: 1 OF 1

CARRIER TAPE SPECIFICATIONS						
PART NUMBER	DESCRIPTION	OVERALL DIMENSIONS	OVERALL HEIGHT	CARRIER TAPE WIDTH	CARRIER TAPE PITCH	PARTS PER REEL
SMS-207-F	FRAME	1.747 X 1.747 [44.37 X 44.37]	.384 [9.75]	72 mm	56 mm	120
SMS-207-C	COVER	1.769 X 1.769 [44.93 X 44.93]	.079 [2.01]	N/A	N/A	BULK PACK

THIS DOCUMENT CONTAINS PROPRIETARY INFORMATION OWNED BY LEADTECH OR DEVELOPED AT ITS OWN PRIVATE EXPENSE AND MAY NOT BE USED, REPRODUCED, COPIED, OR DISCLOSED IN WHOLE OR IN PART FOR ANY PURPOSE INCLUDING DESIGN, MANUFACTURE OR PROCUREMENT WITHOUT THE WRITTEN PERMISSION OF LEADTECH. LEADTECH DOES NOT GUARANTEE OR WARRANT THE PERFORMANCE CHARACTERISTICS.



TITLE: SURFACE MOUNT SHIELD