

SOT-23



TS431-Z

Pin Definition:

1. Reference
2. Cathode
3. Anode

TS431AR-Z

Pin Definition:

1. Cathode
2. Reference
3. Anode

General Description

TS431 integrated circuits are three-terminal programmable shunt regulator diodes. These monolithic IC voltage references operate as a low temperature coefficient zener which is programmable from V_{REF} to 36 volts with two external resistors. These devices exhibit a wide operating current range to 250mA with a typical dynamic impedance of 0.2Ω. The characteristics of these references make them excellent replacements for zener diodes in many applications such as digital voltmeters, power supplies, and op amp circuitry. The 2.495V reference makes it convenient to obtain a stable reference from 5.0V logic supplies, and since The TS431 operates as a shunt regulator, it can be used as either a positive or negative stage reference.

Features

- Programmable Output Voltage up to 36V
- TS431A – V_{REF} 2.495V \pm 1% tolerance
- TS431B – V_{REF} 2.495V \pm 0.5% tolerance
- Fast Turn-On Response
- Sink Current Capability: 200mA
- Low Dynamic Output Impedance: 0.2Ω (Typ)
- Min. Operating Cathode Current: 0.2mA (Typ)
- Halogen Free

Ordering Information

Part No.	Package	Packing
TS431ACX-Z RFG	SOT-23	3kpcs / 7" Reel
TS431ARCX-Z RFG	SOT-23	3kpcs / 7" Reel
TS431BCX-Z RFG	SOT-23	3kpcs / 7" Reel

Note: "G" denotes for Halogen- and Antimony-free as those which contain <900ppm bromine, <900ppm chlorine (<1500ppm total Br + Cl) and <1000ppm antimony compounds

Block Diagram

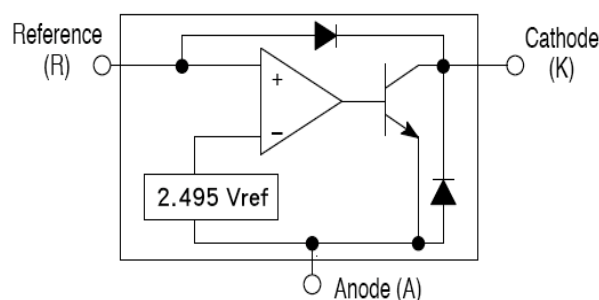

Absolute Maximum Ratings ($T_A = 25^\circ\text{C}$ unless otherwise noted)

Parameter	Symbol	Limit	Unit
Cathode Voltage	V_{KA}	36	V
Continuous Cathode Current Range	I_K	+250	mA
Reference Input Current Range	I_{REF}	10	mA
Power Dissipation	P_D	0.25	W
Operating Temperature Range	T_{OPER}	-20 ~ +85	$^\circ\text{C}$
Junction Temperature	T_J	-40 ~ +125	$^\circ\text{C}$
Storage Temperature Range	T_{STG}	-40 ~ +125	$^\circ\text{C}$
Thermal Resistance Junction to Ambient	$R_{\theta JA}$	156	$^\circ\text{C/W}$

Note: $R_{\theta JA}$ is measured with the PCB copper area of approximately 1 in² (Multi-Layer)

Electrical Characteristics (T_A=25°C, unless otherwise specified)

Parameter	Symbol	Test Conditions	Min	Typ	Max	Unit	
Reference voltage	TS431A	V _{KA} = V _{REF} , I _K = 10mA (Figure 1)	2.470	2.495	2.520	V	
	TS431B		2.483		2.507		
Deviation of reference input voltage	ΔV _{REF}	V _{KA} = V _{REF} , I _K = 10mA (Figure 1) T _A = -20~85°C	--	6	20	mV	
Radio of change in Vref to change in cathode Voltage	ΔV _{REF} / ΔV _{KA}	I _{KA} = 10mA, (Figure 2)	V _{KA} = 10V to V _{REF}	--	-1.2	-2.0	mV/V
			V _{KA} = 36V to 10V	--	-1.0	-2.0	
Reference Input current	I _{REF}	R1=10KΩ, R2=∞, I _{KA} = 10mA (Figure 2)	--	1.5	3.5	μA	
Deviation of reference input current, over temp.	ΔI _{REF}	R1=10KΩ, R2=∞, I _{KA} = 10mA T _A = -20~85°C (Figure 2)	--	0.4	1.2	μA	
Off-state Cathode Current	I _{KA} (off)	V _{REF} = 0V (Figure 3), V _{KA} = 36V	--	0.1	1.0	μA	
Dynamic Output Impedance	Z _{KA}	f < 1KHz, V _{KA} = V _{REF} (Figure 1)	--	0.2	0.5	Ω	
Minimum operating cathode current	I _{KA} (min)	V _{KA} = V _{REF} (Figure 1)	--	0.2	0.5	mA	

* The deviation parameters ΔV_{REF} and ΔI_{REF} are defined as difference between the maximum value and minimum value obtained over the full operating ambient temperature range that applied.

* The average temperature coefficient of the reference input voltage, αV_{REF} is defined as:

$$\alpha V_{ref} \left(\frac{\text{ppm}}{^{\circ}\text{C}} \right) = \frac{\left(\frac{\Delta V_{ref}}{V_{ref} (T_A = 25^{\circ}\text{C})} \times 10^6 \right)}{\Delta T_A}$$

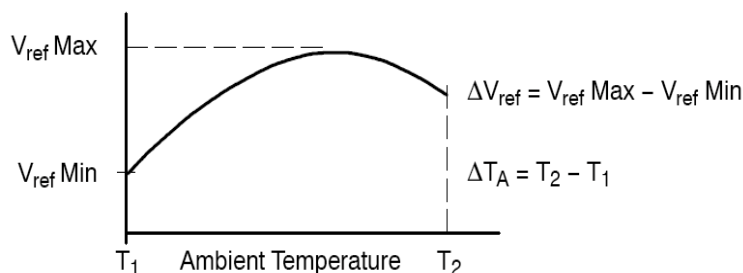

Where: T₂-T₁ = full temperature change.

αV_{REF} can be positive or negative depending on whether the slope is positive or negative.

Example: Maximum V_{REF}=2.496V at 30°C, minimum V_{REF}=2.492V at 0°C, V_{REF}=2.495V at 25°C, ΔT=70°C

$$\alpha V_{REF} = [4\text{mV} / 2495\text{mV}] * 10^6 / 70^{\circ}\text{C} \approx 23\text{ppm}/^{\circ}\text{C}$$

Because minimum V_{REF} occurs at the lower temperature, the coefficient is positive.

* The dynamic impedance Z_{KA} is defined as:

$$|Z_{KA}| = \Delta V_{KA} / \Delta I_{KA}$$

* When the device operating with two external resistors, R1 and R2, (refer to Figure 2) the total dynamic impedance of the circuit is given by:

$$|Z_{KA}| = \Delta v / \Delta i \approx Z_{KA} * (1 + R1 / R2)$$

Adjustable Precision Shunt Regulator

Test Circuits

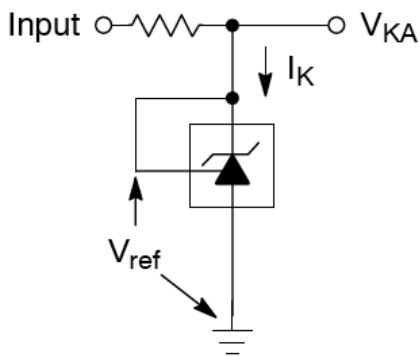

Figure 1: $V_{KA} = V_{REF}$

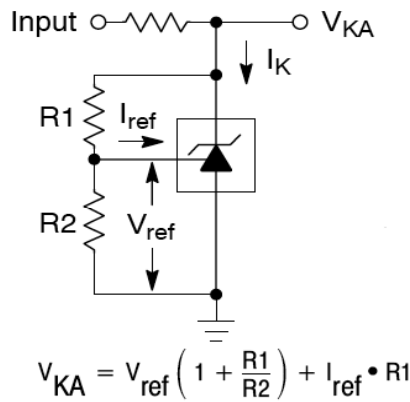

Figure 2: $V_{KA} > V_{REF}$

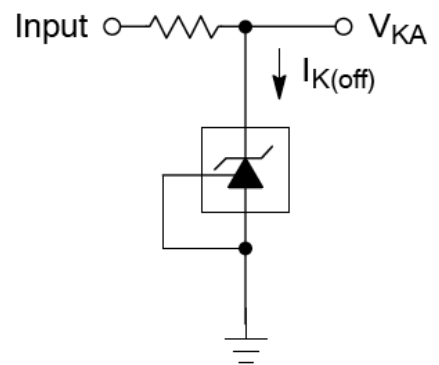

Figure 3: Off-State Current

Additional Information – Stability

When The TS431A/431B is used as a shunt regulator, there are two options for selection of C_L , are recommended for optional stability:

- A) No load capacitance across the device, decouple at the load.
- B) Large capacitance across the device, optional decoupling at the load.

The reason for this is that TS431A/431B exhibits instability with capacitances in the range of 10nF to 1uF (approx.) at light cathode current up to 3mA (typ). The device is less stable the lower the cathode voltage has been set for. Therefore while the device will be perfectly stable operating at a cathode current of 10mA (approx.) with a 0.1uF capacitor across it, it will oscillate transiently during start up as the cathode current passes through the instability region. Select a very low capacitance, or alternatively a high capacitance (10uF) will avoid this issue altogether. Since the user will probably wish to have local decoupling at the load anyway, the most cost effective method is to use no capacitance at all directly across the device. PCB trace/via resistance and inductance prevent the local load decoupling from causing the oscillation during the transient start up phase.

Note: if the TS431A/431B is located right at the load, so the load decoupling capacitor is directly across it, then this capacitor will have to be $\leq 1nF$ or $\geq 10uF$.

Applications Examples (Continue)

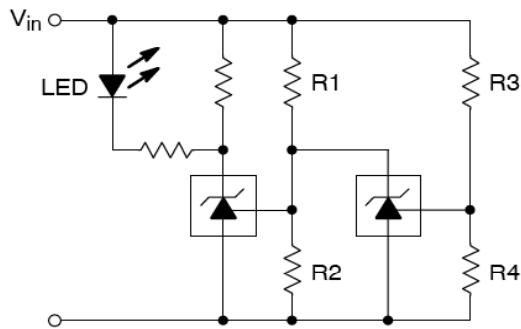

L.E.D. indicator is 'ON' when V_{in} is between the upper and lower limits,

$$\text{Lower limit} = \left(1 + \frac{R1}{R2}\right) V_{ref}$$

$$\text{Upper limit} = \left(1 + \frac{R3}{R4}\right) V_{ref}$$

Figure 4: Voltage Monitor

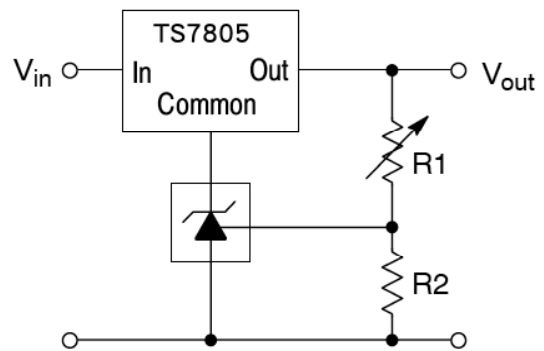

$$V_{out} = \left(1 + \frac{R1}{R2}\right) V_{ref}$$

$$V_{out(min)} = V_{ref} + 5.0 \text{ V}$$

Figure 5: Output Control for Three Terminal Fixed Regulator

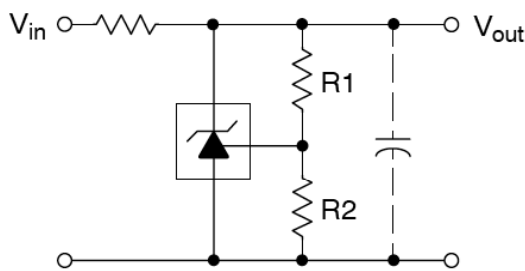

$$V_{out} = \left(1 + \frac{R1}{R2}\right) V_{ref}$$

Figure 6: Shunt Regulator

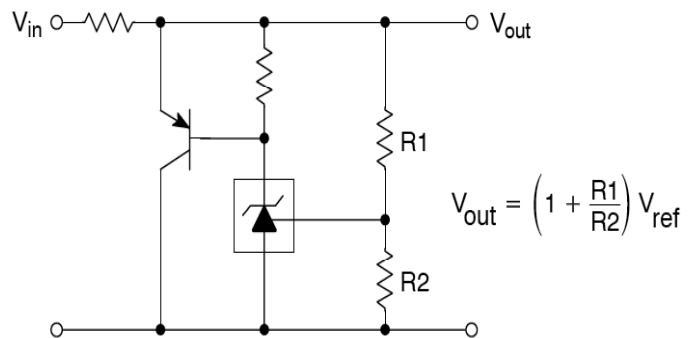

$$V_{out} = \left(1 + \frac{R1}{R2}\right) V_{ref}$$

Figure 7: High Current Shunt Regulator

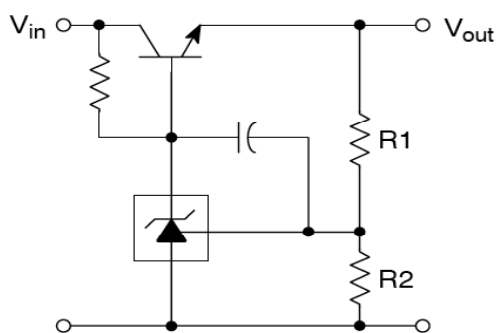

$$V_{out} = \left(1 + \frac{R1}{R2}\right) V_{ref}$$

$$V_{out(min)} = V_{ref} + V_{be} \approx 2.0 \text{ V}$$

Figure 8: Series Pass Regulator

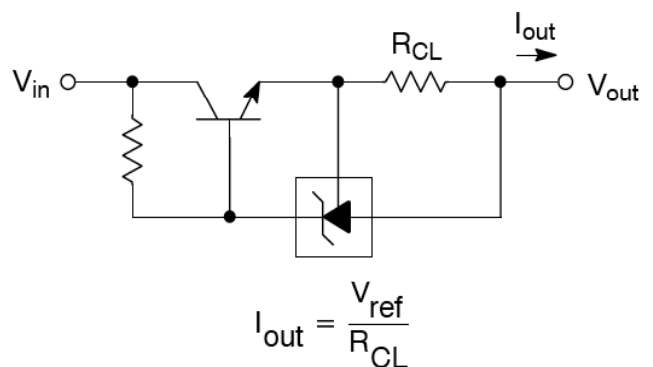

$$I_{out} = \frac{V_{ref}}{R_{CL}}$$

Figure 9: Constant Current Source

Applications Examples (Continue)

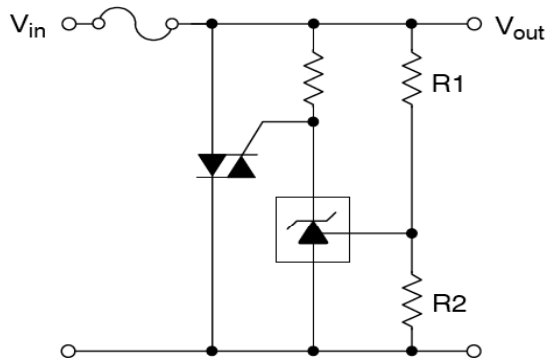

$$V_{out(trip)} = \left(1 + \frac{R1}{R2}\right) V_{ref}$$

Figure 10: TRIAC Crowbar

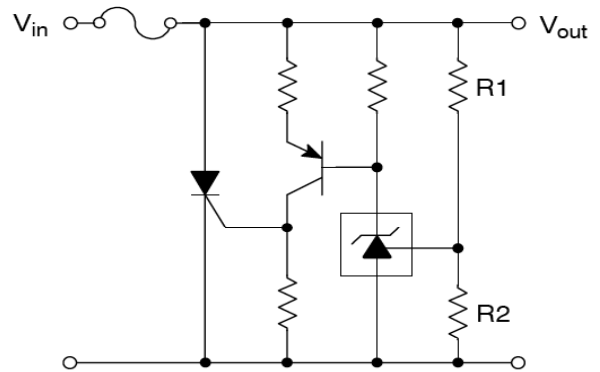

$$V_{out(trip)} = \left(1 + \frac{R1}{R2}\right) V_{ref}$$

Figure 11: SCR Crowbar

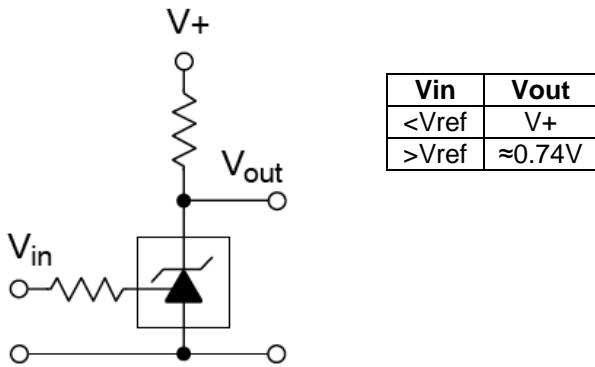

Figure 12: Single-Supply Comparator with Temperature-Compensated Threshold

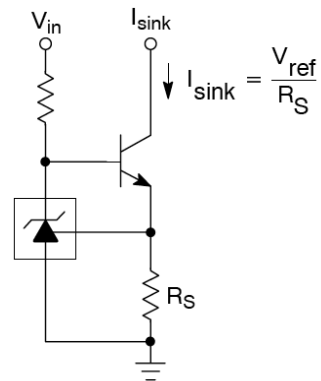
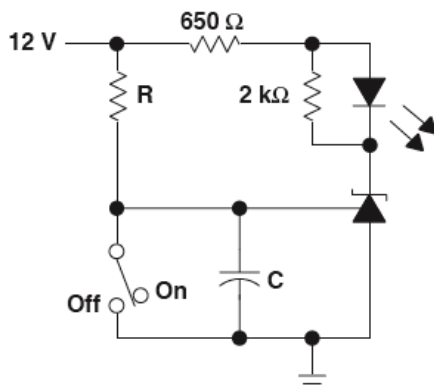

Figure 13: Constant Current Sink



$$Delay = R \times C \times I_n \left(\frac{12V}{12V - V_{ref}} \right)$$

Figure 14: Delay Timer

Typical Performance Characteristics

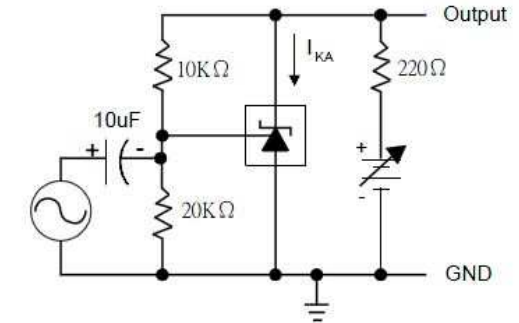
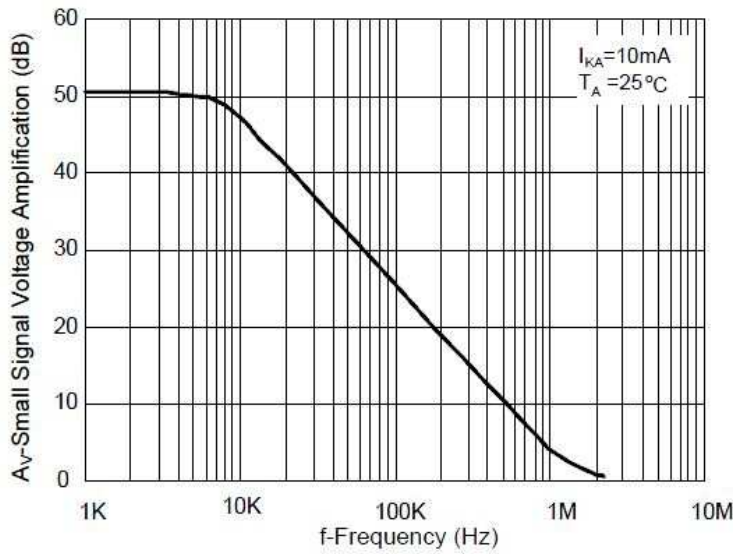

TEST CIRCUIT FOR VOLTAGE AMPLIFICATION

Figure 15: Small-Signal Voltage Gain and Phase Shift vs. Frequency

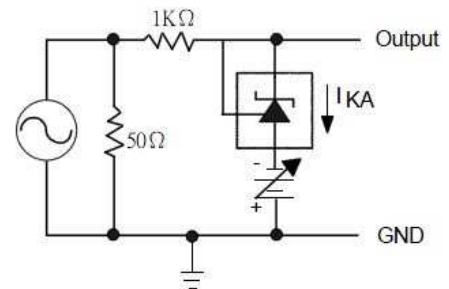
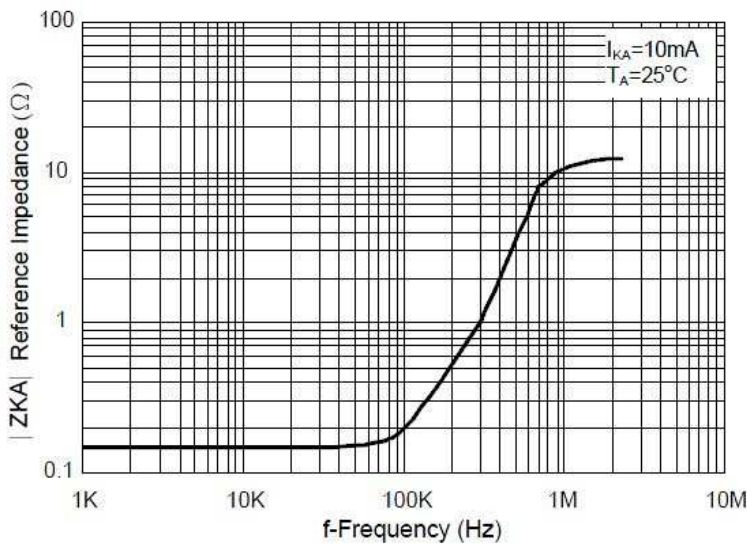

TEST CIRCUIT FOR REFERENCE IMPEDANCE

Figure 16: Reference Impedance vs. Frequency

Typical Performance Characteristics (Continue)

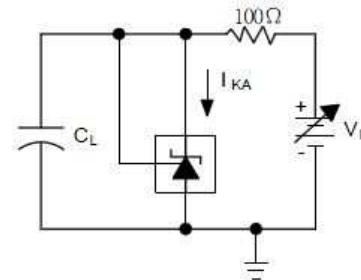
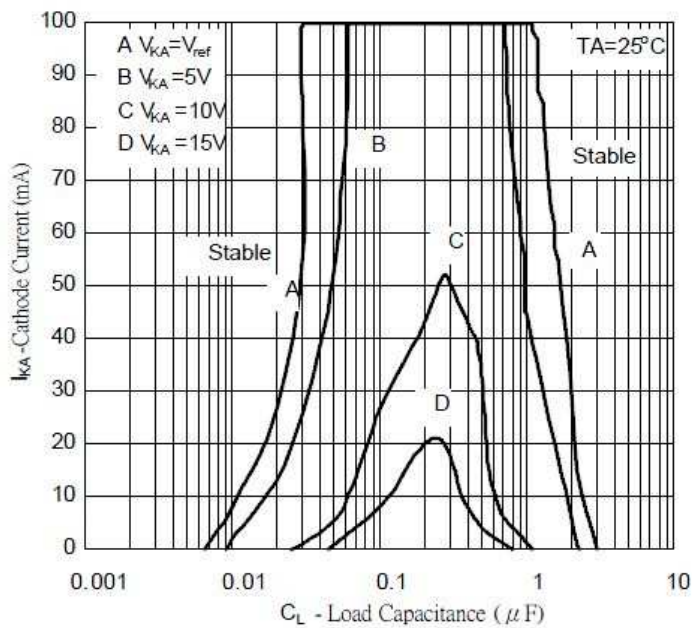

TEST CIRCUIT FOR CURVE A

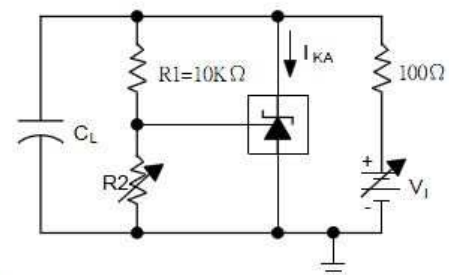

TEST CIRCUIT FOR CURVE B, C, AND D

The areas under the curves represent conditions that may cause the device to oscillate. For curves B, C, and D, R2 and VI were adjusted to establish the initial V_{KA} and I_{KA} conditions with C_L=0. V_{BATT} and C_L were then adjusted to determine the ranges of stability.

Figure 17: Stability Boundary Condition

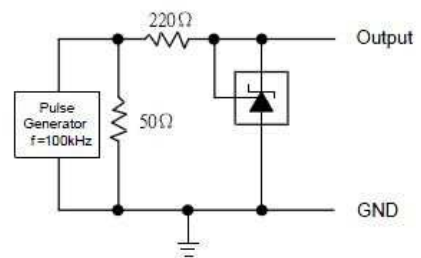
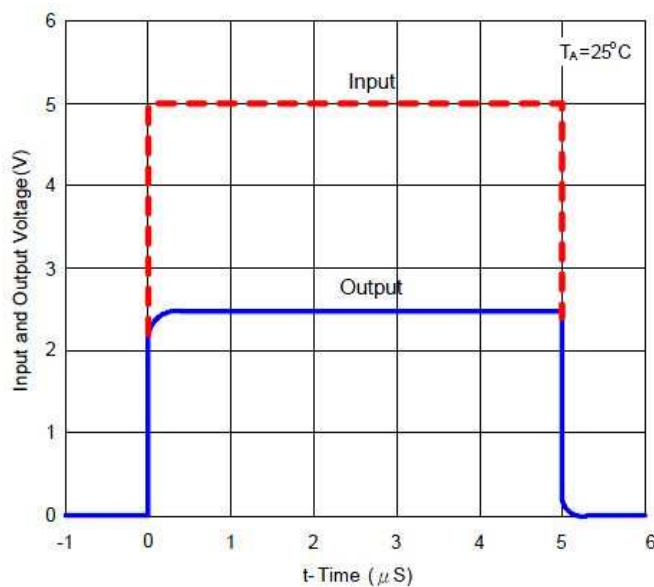

TEST CIRCUIT FOR PULSE RESPONSE

Figure 18: Pulse Response

Electrical Characteristics

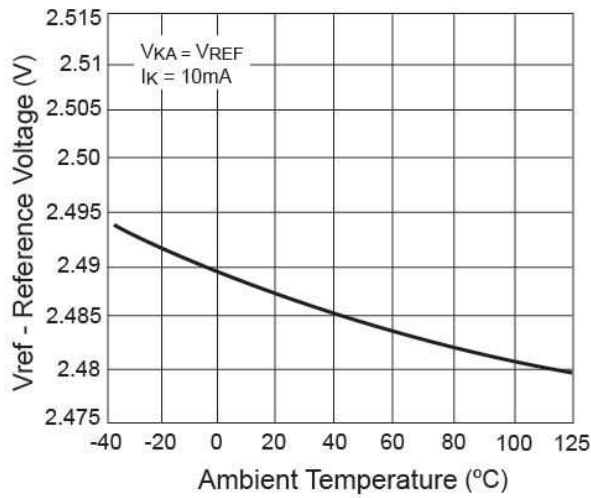

Figure 19: Reference Voltage vs. Temperature

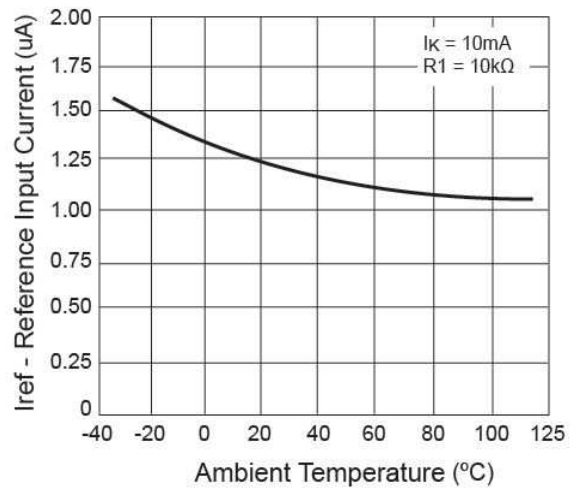

Figure 20: I_{REF} vs. Temperature

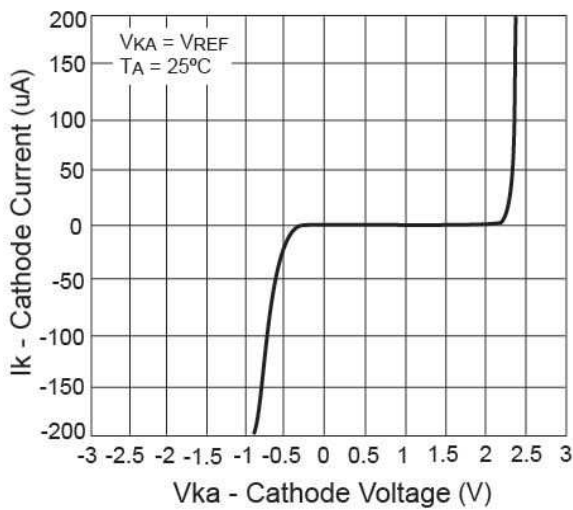

Figure 21: I_{KA} vs. V_{KA} (uA)

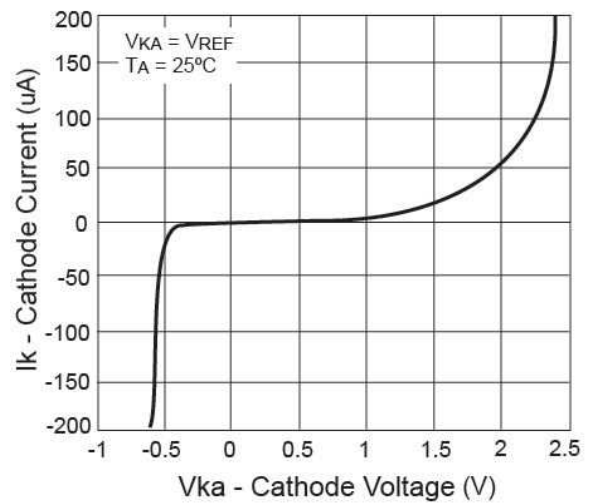
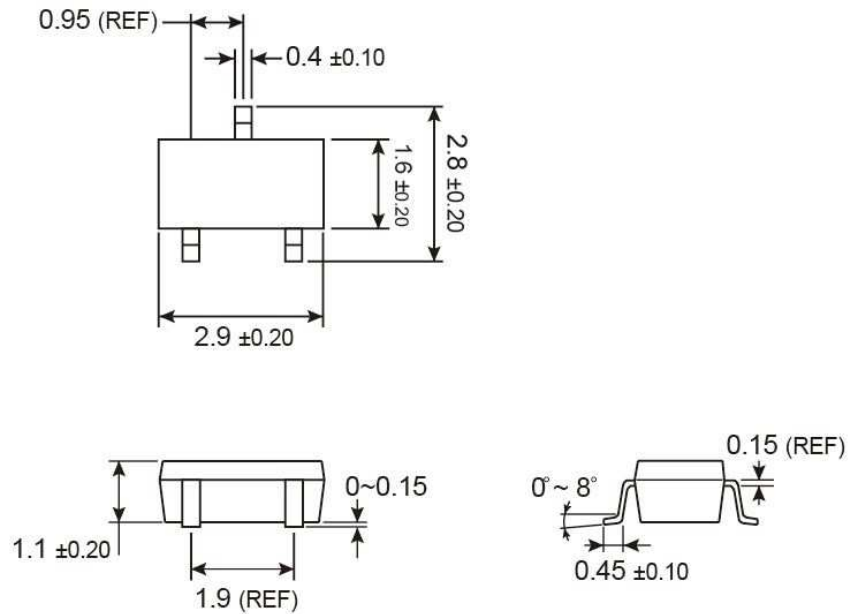

Figure 22: I_{KA} vs. V_{KA} (mA)

SOT-23 Mechanical Drawing



Unit: Millimeters

Marking Diagram

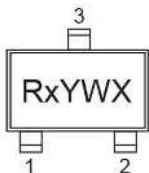

- Rx** = Device Code
 - R1 = TS431A (±1%)
 - RA = TS431AR (±1%)
 - R2 = TS431B (±0.5%)
- Y** = Year Code
 - 2 = 2012, 3 = 2012, 4 = 2014
- W** = Week Code
 - 01 ~ 26 (A~Z)
 - 27 ~ 52 (a ~ z)
- X** = Internal ID Code

Notice

Specifications of the products displayed herein are subject to change without notice. TSC or anyone on its behalf, assumes no responsibility or liability for any errors or inaccuracies.

Information contained herein is intended to provide a product description only. No license, express or implied, to any intellectual property rights is granted by this document. Except as provided in TSC's terms and conditions of sale for such products, TSC assumes no liability whatsoever, and disclaims any express or implied warranty, relating to sale and/or use of TSC products including liability or warranties relating to fitness for a particular purpose, merchantability, or infringement of any patent, copyright, or other intellectual property right.

The products shown herein are not designed for use in medical, life-saving, or life-sustaining applications. Customers using or selling these products for use in such applications do so at their own risk and agree to fully indemnify TSC for any damages resulting from such improper use or sale.