

NOTES: UNLESS OTHERWISE SPECIFIED

- CONSTRUCTION:
HOUSING & PLUNGER: MOLDED NYLON TYPE 6,6.
AVAILABLE IN TEN COLORS.
CONTACT BLADE: NICKEL SILVER ALLOY CA 770.
SPRING: STAINLESS STEEL TYPE 302.

- PERFORMANCE:
MAXIMUM CURRENT: 13.1 AMPS WITH A 76°
TEMPERATURE RISE.
MAXIMUM VOLTAGE: 2.4 KV
MAXIMUM TEMPERATURE: 200°F (93°C)

- FEATURES:
HOOK PIERCES WIRE UP TO $\phi 0.140$ " [3.56].
FIELD SERVICEABLE.

LTR	DESCRIPTION	REVISIONS		DATE	APPROVED
		NO.	DESCRIPTION		

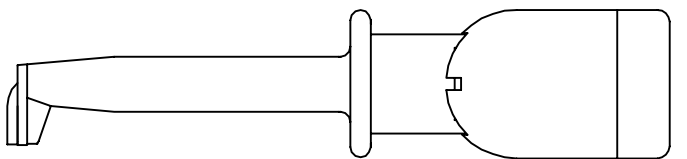
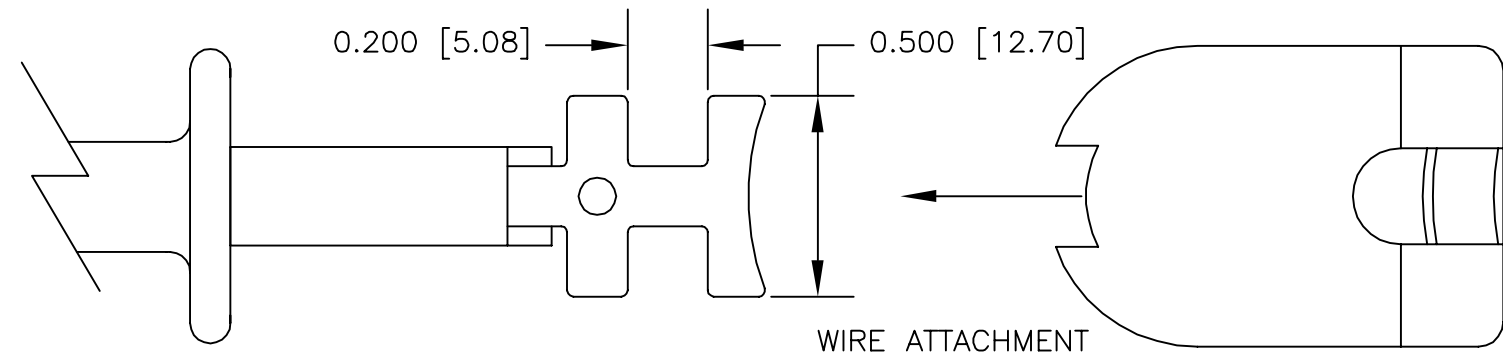
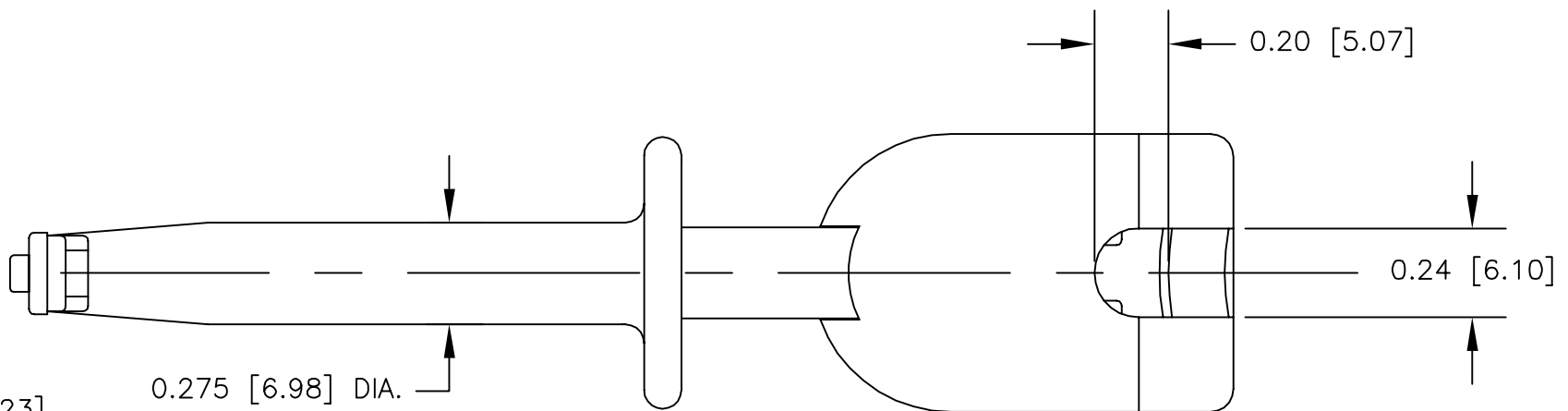
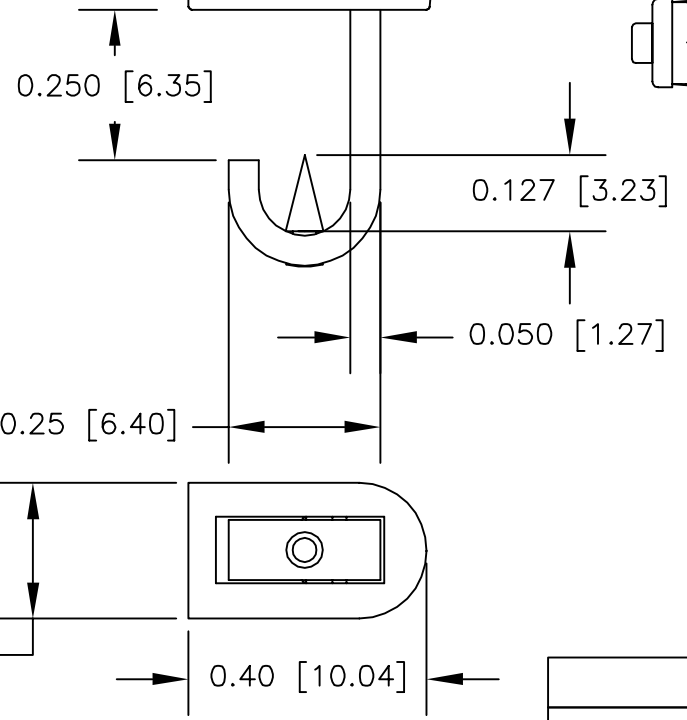
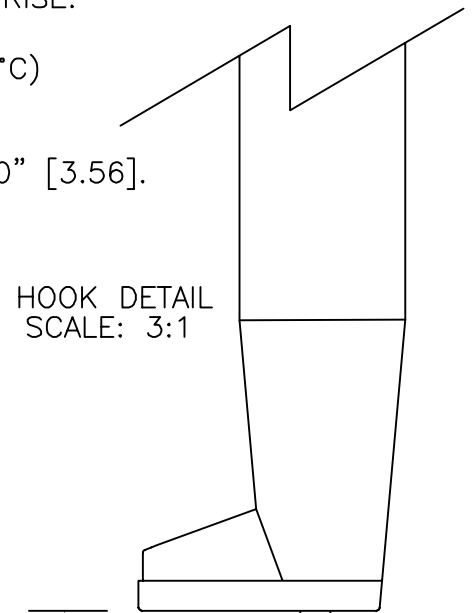
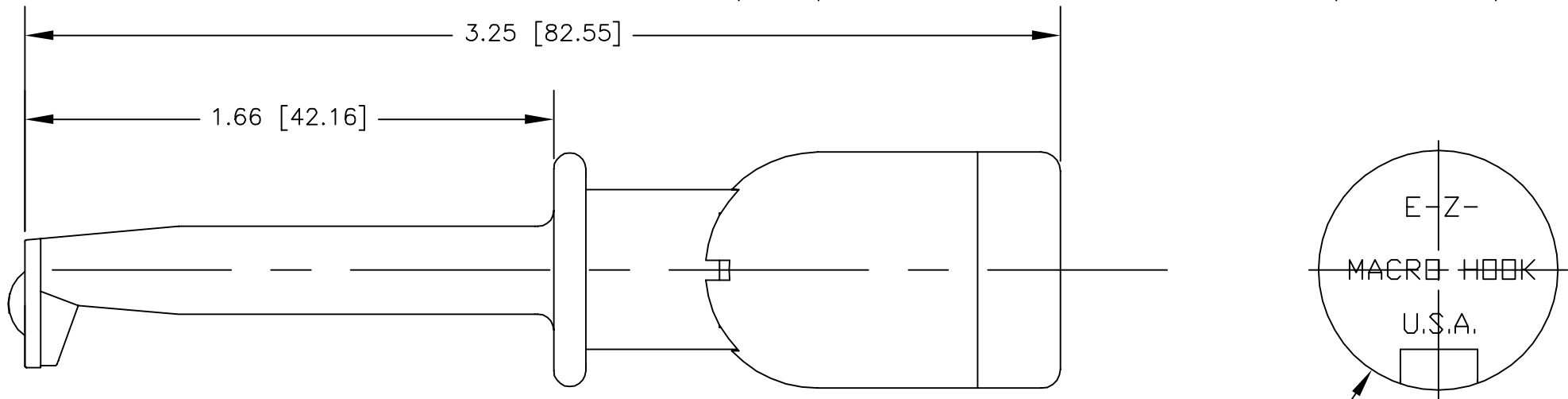

ACTUAL SIZE

UNLESS OTHERWISE SPECIFIED DIMENSIONS ARE IN INCHES TOLERANCES ARE: FRACTIONS DECIMALS ANGLES ± .XX ± ± .XXX ±		CONTRACT NO.		DIVISION OF TEKTEST INC. ARCADIA, CA 91006 U.S.A.			
MATERIAL SEE NOTE.		APPROVALS DRAWN R.L.	DATE 6/09			DESCRIPTION E-Z-MACRO HOOK INSULATION-PIERCING	
FINISH SEE NOTE.		APPROVED BY		SIZE B	CODE IDENT NO. 08505	DRAWING NO. XJ	REV.
NEXT ASSY	USED ON	DO NOT SCALE DRAWING		SCALE 2:1		SHEET 1 OF 1	