

THIS COPY IS PROVIDED ON A RESTRICTED BASIS AND IS NOT TO BE USED IN ANY WAY DETRIMENTAL TO THE INTERESTS OF PANDUIT CORP.

Material	High Conductivity Seamless Copper Tube
Plating	Electro-Tin
Wire Size	750 kcmil
Wire Type	Stranded Copper: Class B: Compact, Compressed or Concentric, Class C: Concentric
Wire Strip Length	2-15/16 in.
Stud Size	1/2 in.
UL Listed Wire Connector	Yes, for applications up to 35kv. Consult cable manufacturer for voltage stress relief instructions with applications greater than 2000 volts.
UL Temperature Rating	90° C
C.SA Certified Wire Connector	Yes
Panduit Color Code on Barrel	BLACK
Panduit Die Index No. on Barrel	P106
Alternate Industry Die Index No. ( ) on Barrel	(24)

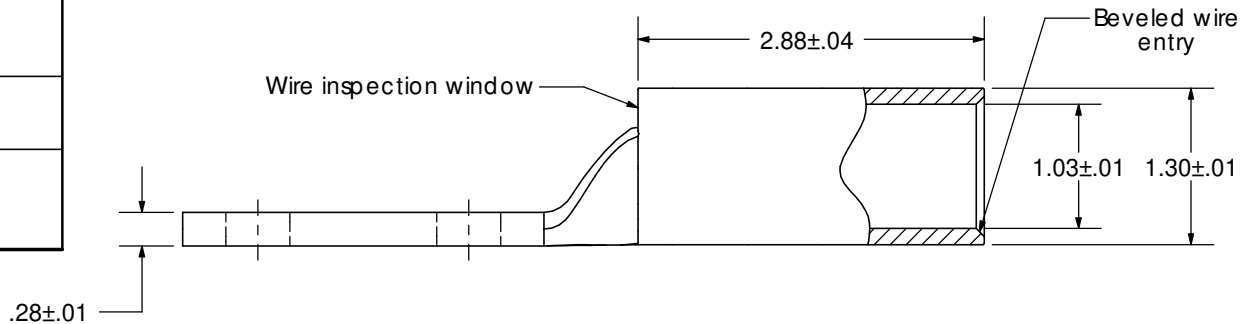
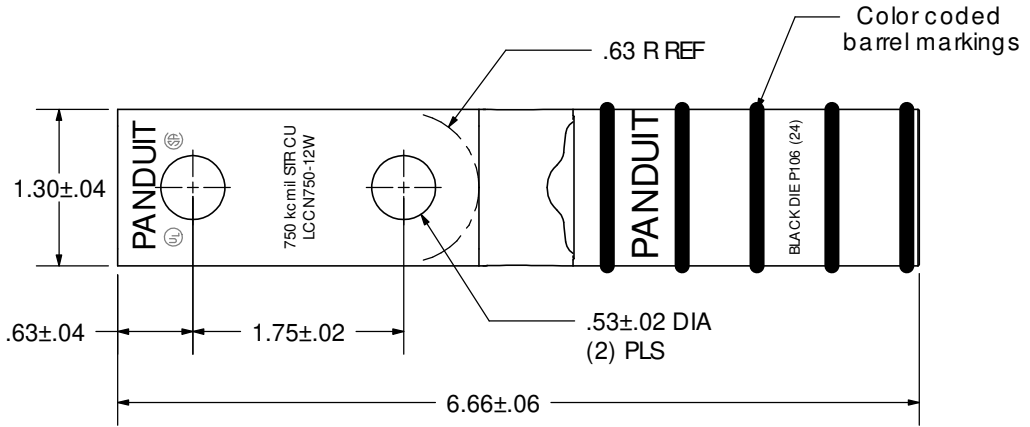

CERTIFIED

LISTED Wire Connector

**PANDUIT** CORP. TINLEY PARK, ILLINOIS

LCCN750-12W-6  
Copper Lug - Two-Hole Narrow Tongue, Long Barrel with Window

01	8/05	KLFU	KLFU	TONGUE THICKNESS WAS .263	PC00105
REV	DATE	BY	CHK	DESCRIPTION	ECN

SCALE N/A

DRAWING NO / CAD FILE LCCN750-12W-CUST