

5 V-12 V, 15 W double output isolated flyback converter based on VIPer37LD

Data brief

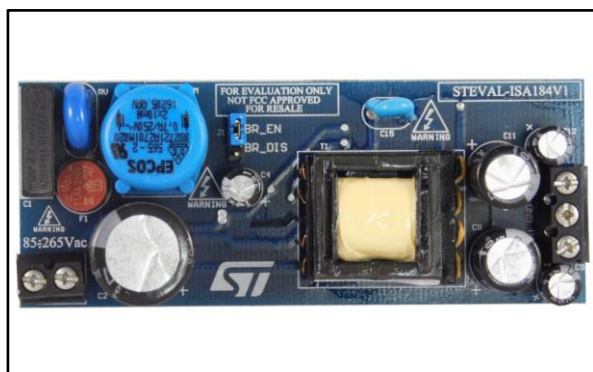

Features

- Universal input mains range: 85 – 265 V_{AC}; frequency: 50 – 60 Hz
- Output voltage 1: 5 V / 1.2 A
- Output voltage 2: 12 V / 0.75 A
- Very compact size
- Standby mains consumption: < 40 mW at 230 V_{AC}
- Average efficiency: > 75%
- EMI: according to EN55022-Class-B
- RoHS compliant

Description

The STEVAL-ISA184V1 evaluation board implements an isolated flyback double output (5 V / 1.2 A and 12 V / 0.75 A) 15 W wide range mains developed for general purpose applications.

The core of the application is the VIPer37LD off-line high voltage converter from the VIPerPlus family.

The device is a high-voltage converter that intelligently integrates an 800 V rugged power MOSFET with PWM current-mode control.

The main characteristics of the evaluation board are its small size and minimal BOM, high efficiency and low standby consumption. Extremely low consumption under no-load conditions is ensured thanks to burst mode operation, which reduces the average switching frequency and minimizes all frequency-related losses.

The VIPer37LD operates at 60 kHz fixed frequency, and frequency jittering is implemented to help meet the standards regarding electromagnetic disturbance. The several protections on the device like overvoltage, overload, output short circuit, secondary winding short, hard transformer saturation protection and brown out protections improve the safety and reliability of the design.

1 Schematic diagram

Figure 1: STEVAL-ISA184V1 circuit schematic

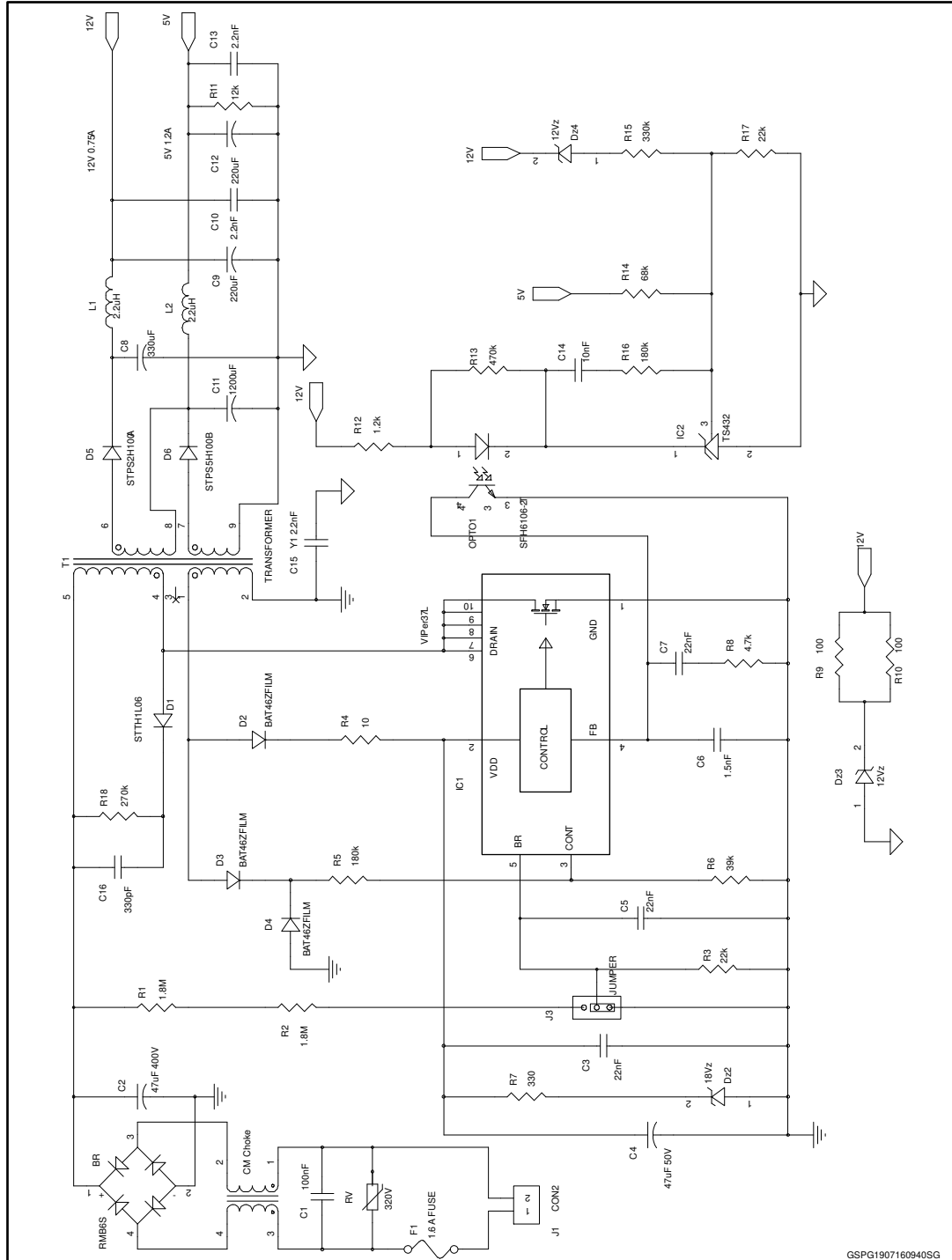

GSPG1907160940SG

2 Revision history

Table 1: Document revision history

Date	Version	Changes
13-Dec-2016	1	Initial release.

IMPORTANT NOTICE – PLEASE READ CAREFULLY

STMicroelectronics NV and its subsidiaries ("ST") reserve the right to make changes, corrections, enhancements, modifications, and improvements to ST products and/or to this document at any time without notice. Purchasers should obtain the latest relevant information on ST products before placing orders. ST products are sold pursuant to ST's terms and conditions of sale in place at the time of order acknowledgement.

Purchasers are solely responsible for the choice, selection, and use of ST products and ST assumes no liability for application assistance or the design of Purchasers' products.

No license, express or implied, to any intellectual property right is granted by ST herein.

Resale of ST products with provisions different from the information set forth herein shall void any warranty granted by ST for such product.

ST and the ST logo are trademarks of ST. All other product or service names are the property of their respective owners.

Information in this document supersedes and replaces information previously supplied in any prior versions of this document.

© 2016 STMicroelectronics – All rights reserved