

Features

- Wirewound and Hybritron® elements
- High rotational life
- Optional 0.1 % linearity
- Optional A/R lug
- RoHS compliant*
- Suitable for use under some side load conditions
- Designed for HMI and MMI applications
- Dual gang option
- Servo mount option
- Dual ball bearing option

3549 - 10-Turn Precision Potentiometer

Electrical Characteristics ¹	Wirewound Element	Hybritron® Element
Standard Resistance Range.....	100 to 100K ohms.....	1K to 100K ohms
Total Resistance Tolerance.....	±3 %.....	±10 %
Independent Linearity.....	±0.2 %.....	±0.2 %
Independent Linearity (Maximum Practical).....	±0.1 %.....	±0.1 %
Effective Electrical Angle.....	3600 ° +10 °, -0 °.....	3600 ° +10 °, -0 °
Absolute Minimum Resistance/End Voltage.....	1 ohm or 0.1 % maximum.....	0.2 % maximum
(whichever is greater)		
Noise/Output Smoothness.....	100 ohms maximum.....	0.10 % maximum
Max. Wiper Current @ 5K ohms.....	20 mA.....	10 mA
Dielectric Withstanding Voltage (MIL-STD-202, Method 301)		
Sea Level.....	1,000 VAC minimum.....	1,000 VAC minimum
Insulation Resistance (500 VDC).....	1,000 megohms minimum.....	1,000 megohms minimum
Resolution.....	See How to Order chart.....	Essentially infinite
Power Rating (Voltage Limited By Power Dissipation)		
+70 °C.....	2 watts.....	2 watts
+125 °C.....	0 watt.....	0 watt

Environmental Characteristics ¹	Wirewound Element	Hybritron® Element
Operating Temperature Range		
Dynamic.....	-40 °C to +125 °C.....	-40 °C to +125 °C
Static.....	-55 °C to +125 °C.....	-55 °C to +125 °C
Temperature Coefficient (Over Static Temperature Range).....	±50 ppm/°C.....	±100 ppm/°C
Temperature Cycling (5 Cycles Over Static Temperature Range).....	±2 % TR shift max.....	±4 % TR shift max.
Vibration (15 Gs, 10 Hz to 2 kHz)		
Wiper Bounce.....	0.1 ms max.....	0.1 ms max.
Shock (100 Gs, 6 ms sawtooth)		
Wiper Bounce.....	0.1 ms max.....	0.1 ms max.
Load Life (1,000 hours @ 70 °C).....	±2 % TR shift.....	±5 % TR shift max.
Rotational Life		
No Load or Powered.....	2,000,000 shaft revolutions.....	5,000,000 shaft revolutions
No Load or Powered (Dual Ball Bearing).....	N/A.....	10,000,000 shaft revolutions
Moisture Resistance (Mil-Std-202, Method 103).....	±2 % TR shift max.....	±5 % TR shift max.
IP Rating.....	IP 50.....	IP 50

Mechanical Characteristics ¹	Wirewound Element	Hybritron® Element
Mechanical Angle.....		3600 ° +10 °, -0 °
Backlash.....		1.0 ° max.
Stop Strength.....		53 N-cm (75 oz-in.) min.
Torque		
Starting.....		0.5 N-cm (0.7 oz-in.) max.
Running.....		0.5 N-cm (0.7 oz-in.) max.
Clutch.....		1.0 to 4.2 N-cm (1.5 to 6.0 oz-in.)
Mounting.....		170-200 N-cm (15-18 in.-lb.) max.
Shaft Runout T.I.R.....		0.08 mm (0.003 in.)
Lateral Runout T.I.R.....		0.13 mm (0.005 in.)
Shaft End Play T.I.R.....		0.15 mm (0.006 in.)
Shaft Radial Play T.I.R.....		0.08 mm (0.003 in.)
Pilot Diameter Runout T.I.R.....		0.08 mm (0.003 in.)
Weight		
Single.....		20 gm (0.7 oz.) typ.
Dual.....		36 gm (1.27 oz) typ.
Shaft Side Load (Max. Allowable)		
Nickel Plated Brass Shaft w/Brass Bushing.....		50 gmf (1.7 ozf)
Stainless Steel Shaft w/Bronze Bushing.....		250 gmf (8.8 ozf)
Terminals.....		Gold-plated solder lugs
Soldering Condition		
Manual Soldering.....	96.5Sn/3.0Ag/0.5Cu solid wire or no-clean rosin cored wire, 370 °C (700 °F) max. for 3 seconds	
Wave Soldering.....	96.5Sn/3.0Ag/0.5Cu solder with no-clean flux, 260 °C (500 °F) max. for 5 seconds	
Wash processes.....		Not recommended
Mounting Hardware.....	One lockwasher and one mounting nut is shipped with each potentiometer	
Recommended Panel Thickness (Bushing Mount).....		2.46-3.81 mm (0.097-0.150 in.)
Marking.....	Manufacturer's symbol, model number, product code and date code	
Standard Packaging.....	Plastic trays (5 pcs./tray)	

¹At room ambient: +25 °C nominal and 50 % relative humidity nominal, except as noted.
For other options, please consult factory.



WARNING
Cancer and Reproductive Harm
www.P65Warnings.ca.gov

*RoHS Directive 2015/863, Mar 31, 2015 and Annex.

Specifications are subject to change without notice. Users should verify actual device performance in their specific applications. The products described herein and this document are subject to specific legal disclaimers as set forth on the last page of this document, and at www.bourns.com/docs/legal/disclaimer.pdf

3549 - 10-Turn Precision Potentiometer

BOURNS®

Product Dimensions

Single Gang, Bushing Mount

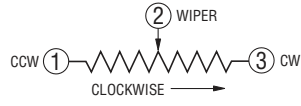
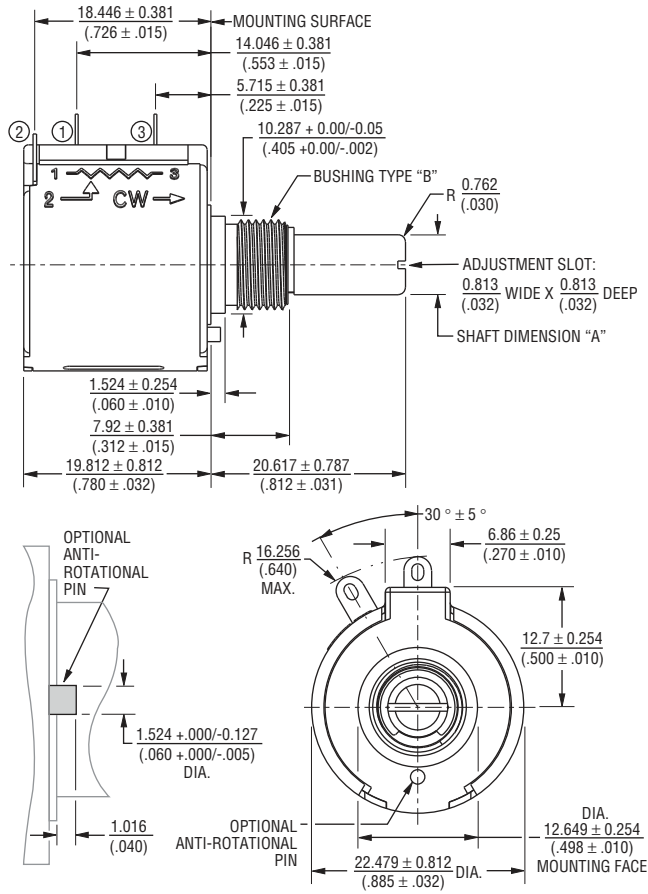

TOLERANCES: EXCEPT WHERE NOTED
 DECIMALS: .XX ± .50 / (.02) .XXX ± .127 / (.005) .XXXX ± .0127 / (.0005)
 DIMENSIONS: MM / (IN)

Bushing Selection Code	Shaft Dimension "A"	Shaft Material	Bushing Type "B"	Bushing Material
A	6.34 +0/-0.022 (0.2497 +0/-0.0009)	Nickel Plated Brass	3/8 " 32-UNEF- 2A THD.	Brass
B	6.00 +0/-0.022 (0.2362 +0/-0.0009)	Nickel Plated Brass	M9 X 0.75-8g	Brass
C	6.34 +0/-0.007 (0.2497 +0/-0.0003)	Stainless Steel	3/8 " 32-UNEF- 2A THD.	Bronze
D	6.00 +0/-0.007 (0.2362 +0/-0.0003)	Stainless Steel	M9 X 0.75-8g	Bronze
G	6.34 +0/-0.007 (0.2497 +0/-0.0003)	Stainless Steel	3/8 " 32-UNEF- 2A THD.	Bronze
H	6.00 +0/-0.007 (0.2362 +0/-0.0003)	Stainless Steel	M9 X 0.75-8g	Bronze

Dual Gang, Bushing Mount

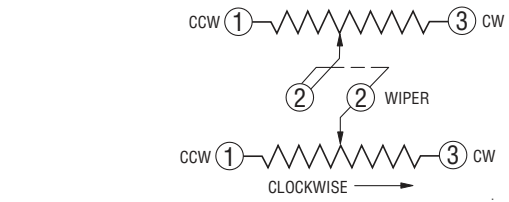
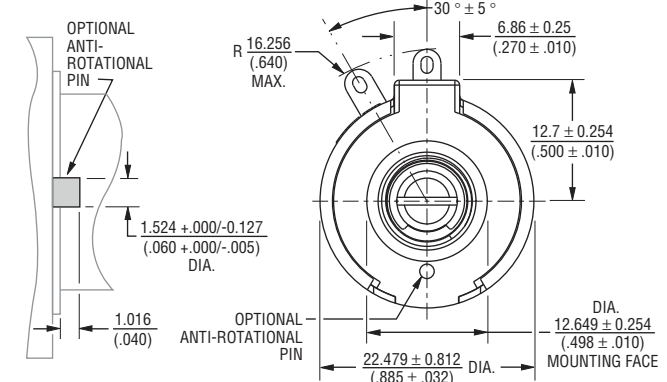
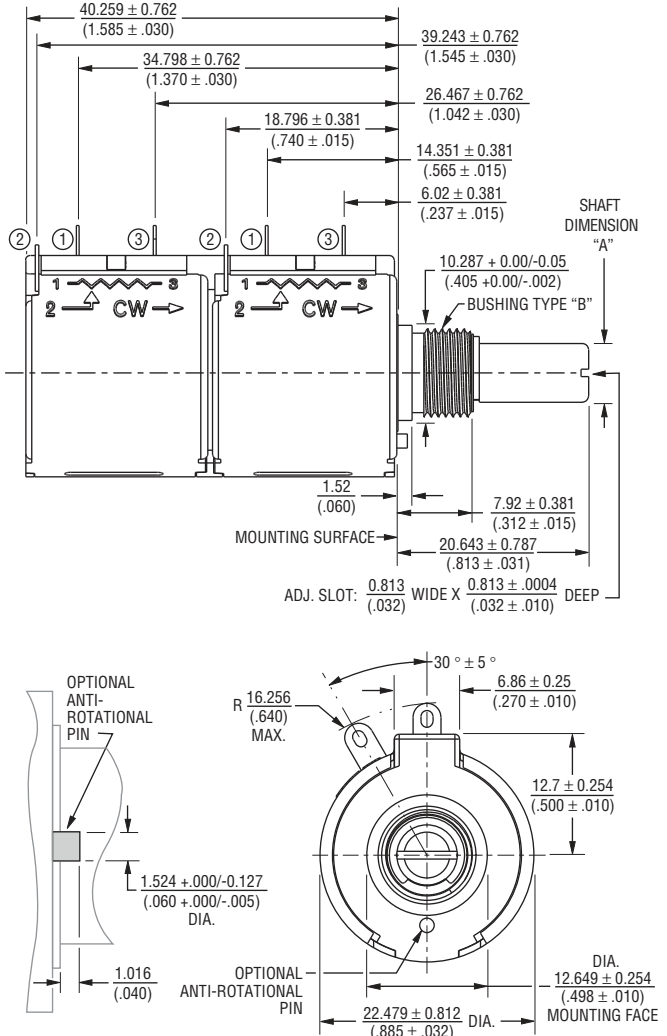

Specifications are subject to change without notice.
 Users should verify actual device performance in their specific applications.
 The products described herein and this document are subject to specific legal disclaimers as set forth on the last page of this document, and at www.bourns.com/docs/legal/disclaimer.pdf.

3549 - 10-Turn Precision Potentiometer

BOURNS®

Product Dimensions

Single Gang, Servo Mount

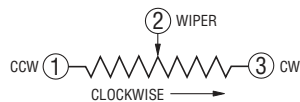
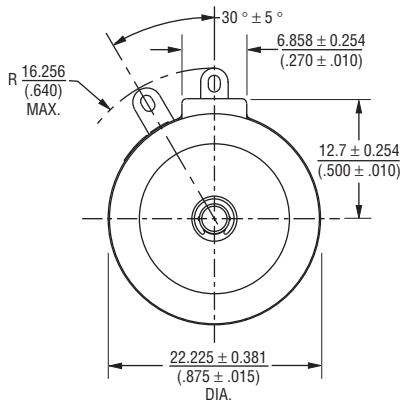
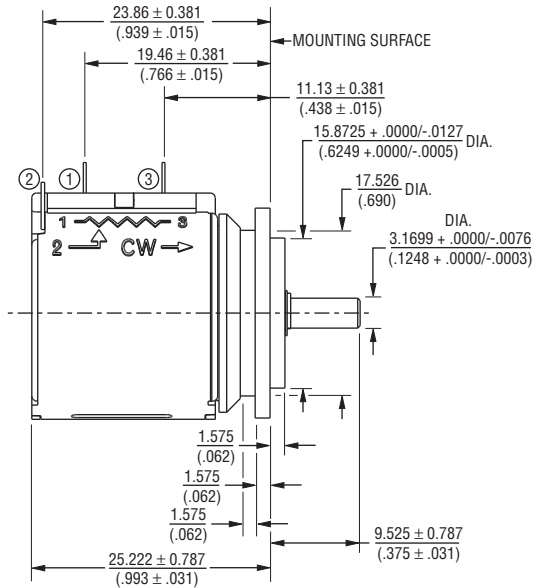

TOLERANCES: EXCEPT WHERE NOTED
 DECIMALS: .XX ± .50 (.02) .XXX ± .127 (.005) .XXXX ± .0127 (.0005)
 DIMENSIONS: $\frac{MM}{(IN)}$

Single Gang, Servo Mount, Dual Ball Bearing

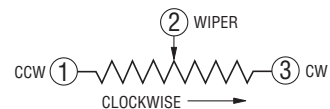
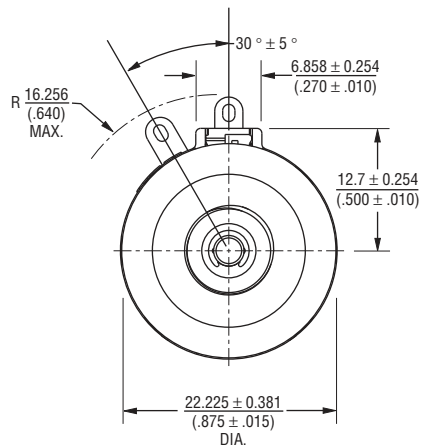
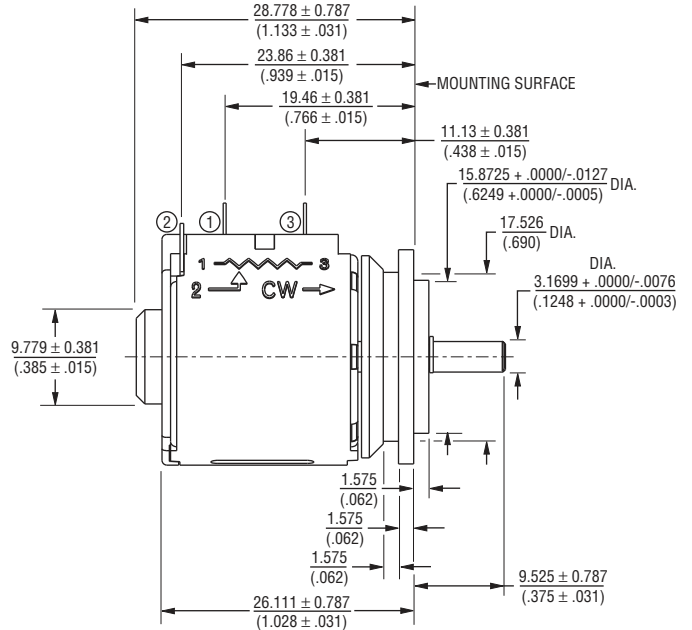

Specifications are subject to change without notice.
 Users should verify actual device performance in their specific applications.
 The products described herein and this document are subject to specific legal disclaimers as set forth on the last page of this document, and at www.bourns.com/docs/legal/disclaimer.pdf.

3549 - 10-Turn Precision Potentiometer

BOURNS®

Product Dimensions

Dual Gang, Servo Mount

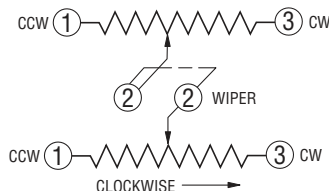
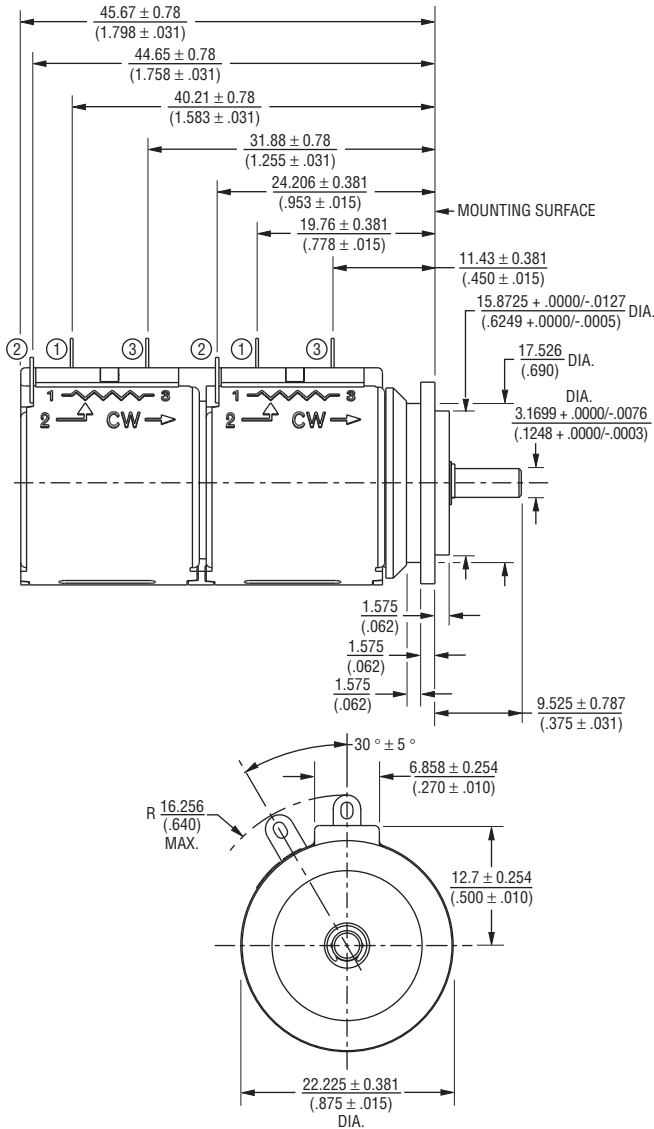

Panel Thickness Dimensions

(For Bushing Mount Only)

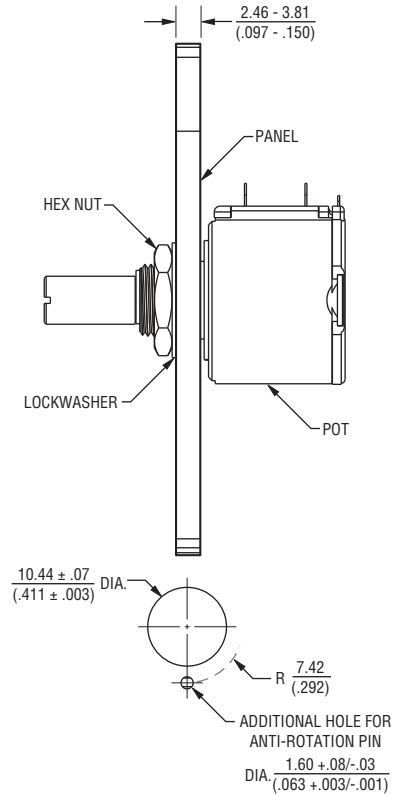

Anti-rotation pin hole is shown at six o'clock position for reference only. The actual location is determined by the customer's application. Refer to the front view of the potentiometer to see the location of the optional A/R pin.

Panel thickness and hole diameters are recommended for best fit. However, customers may adjust the dimensions to suit their specific application.

DIMENSIONS: $\frac{\text{MM}}{\text{(INCHES)}}$ TOLERANCES: $\pm \frac{0.127}{(.005)}$

3549 - 10-Turn Precision Potentiometer

BOURNS®

How To Order

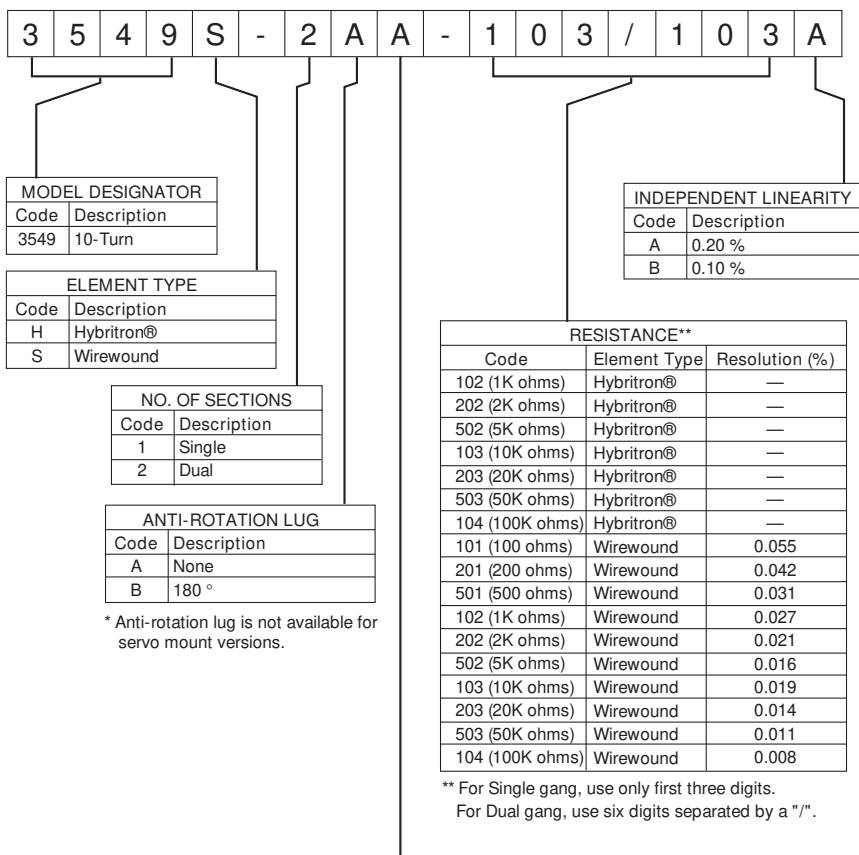

BUSHING MOUNT						
Code	Shaft FMS	Shaft Dia.	Shaft Material	Bushing Dia.	Bushing Material	Slip Clutch
A	13/16"	1/4"	Nickel Plated Brass	3/8"	Brass	N/A
B	20.6 mm	6 mm	Nickel Plated Brass	9 mm	Brass	N/A
C	13/16"	1/4"	Stainless Steel	3/8"	Bronze	N/A
D	20.6 mm	6 mm	Stainless Steel	9 mm	Bronze	N/A
G	13/16"	1/4"	Stainless Steel	3/8"	Bronze	Yes***
H	20.6 mm	6 mm	Stainless Steel	9 mm	Bronze	Yes***

SERVO MOUNT				
Code	Shaft FMS	Shaft Dia.	Shaft Material	Ball Bearings
E	3/8"	1/8"	Stainless Steel	N/A
F	3/8"	1/8"	Stainless Steel	Front & Rear****

*** Not available in dual gang version.

**** Available in Hybritron® version only and limited to single section.

REV. 10/19

"Hybritron" is a registered trademark of Bourns, Inc.

Specifications are subject to change without notice.

Users should verify actual device performance in their specific applications.

The products described herein and this document are subject to specific legal disclaimers as set forth on the last page of this document, and at www.bourns.com/docs/legal/disclaimer.pdf.

This legal disclaimer applies to purchasers and users of Bourns® products manufactured by or on behalf of Bourns, Inc. and its affiliates (collectively, “Bourns”).

Unless otherwise expressly indicated in writing, Bourns® products and data sheets relating thereto are subject to change without notice. Users should check for and obtain the latest relevant information and verify that such information is current and complete before placing orders for Bourns® products.

The characteristics and parameters of a Bourns® product set forth in its data sheet are based on laboratory conditions, and statements regarding the suitability of products for certain types of applications are based on Bourns’ knowledge of typical requirements in generic applications. The characteristics and parameters of a Bourns® product in a user application may vary from the data sheet characteristics and parameters due to (i) the combination of the Bourns® product with other components in the user’s application, or (ii) the environment of the user application itself. The characteristics and parameters of a Bourns® product also can and do vary in different applications and actual performance may vary over time. Users should always verify the actual performance of the Bourns® product in their specific devices and applications, and make their own independent judgments regarding the amount of additional test margin to design into their device or application to compensate for differences between laboratory and real world conditions.

Unless Bourns has explicitly designated an individual Bourns® product as meeting the requirements of a particular industry standard (e.g., ISO/TS 16949) or a particular qualification (e.g., UL listed or recognized), Bourns is not responsible for any failure of an individual Bourns® product to meet the requirements of such industry standard or particular qualification. Users of Bourns® products are responsible for ensuring compliance with safety-related requirements and standards applicable to their devices or applications.

Bourns® products are not recommended, authorized or intended for use in nuclear, lifesaving, life-critical or life-sustaining applications, nor in any other applications where failure or malfunction may result in personal injury, death, or severe property or environmental damage. Unless expressly and specifically approved in writing by two authorized Bourns representatives on a case-by-case basis, use of any Bourns® products in such unauthorized applications might not be safe and thus is at the user’s sole risk. Life-critical applications include devices identified by the U.S. Food and Drug Administration as Class III devices and generally equivalent classifications outside of the United States.

Bourns expressly identifies those Bourns® standard products that are suitable for use in automotive applications on such products’ data sheets in the section entitled “Applications.” Unless expressly and specifically approved in writing by two authorized Bourns representatives on a case-by-case basis, use of any other Bourns® standard products in an automotive application might not be safe and thus is not recommended, authorized or intended and is at the user’s sole risk. If Bourns expressly identifies a sub-category of automotive application in the data sheet for its standard products (such as infotainment or lighting), such identification means that Bourns has reviewed its standard product and has determined that if such Bourns® standard product is considered for potential use in automotive applications, it should only be used in such sub-category of automotive applications. Any reference to Bourns® standard product in the data sheet as compliant with the AEC-Q standard or “automotive grade” does not by itself mean that Bourns has approved such product for use in an automotive application.

Bourns® standard products are not tested to comply with United States Federal Aviation Administration standards generally or any other generally equivalent governmental organization standard applicable to products designed or manufactured for use in aircraft or space applications. Bourns expressly identifies Bourns® standard products that are suitable for use in aircraft or space applications on such products’ data sheets in the section entitled “Applications.” Unless expressly and specifically approved in writing by two authorized Bourns representatives on a case-by-case basis, use of any other Bourns® standard product in an aircraft or space application might not be safe and thus is not recommended, authorized or intended and is at the user’s sole risk.

The use and level of testing applicable to Bourns® custom products shall be negotiated on a case-by-case basis by Bourns and the user for which such Bourns® custom products are specially designed. Absent a written agreement between Bourns and the user regarding the use and level of such testing, the above provisions applicable to Bourns® standard products shall also apply to such Bourns® custom products.

Users shall not sell, transfer, export or re-export any Bourns® products or technology for use in activities which involve the design, development, production, use or stockpiling of nuclear, chemical or biological weapons or missiles, nor shall they use Bourns® products or technology in any facility which engages in activities relating to such devices. The foregoing restrictions apply to all uses and applications that violate national or international prohibitions, including embargos or international regulations. Further, Bourns® products and Bourns technology and technical data may not under any circumstance be exported or re-exported to countries subject to international sanctions or embargoes. Bourns® products may not, without prior authorization from Bourns and/or the U.S. Government, be resold, transferred, or re-exported to any party not eligible to receive U.S. commodities, software, and technical data.

To the maximum extent permitted by applicable law, Bourns disclaims (i) any and all liability for special, punitive, consequential, incidental or indirect damages or lost revenues or lost profits, and (ii) any and all implied warranties, including implied warranties of fitness for particular purpose, non-infringement and merchantability.

For your convenience, copies of this Legal Disclaimer Notice with German, Spanish, Japanese, Traditional Chinese and Simplified Chinese bilingual versions are available at:

Web Page: <http://www.bourns.com/legal/disclaimers-terms-and-policies>

PDF: <http://www.bourns.com/docs/Legal/disclaimer.pdf>