

Energy harvesting demonstration kit based on SPV1050

Data brief

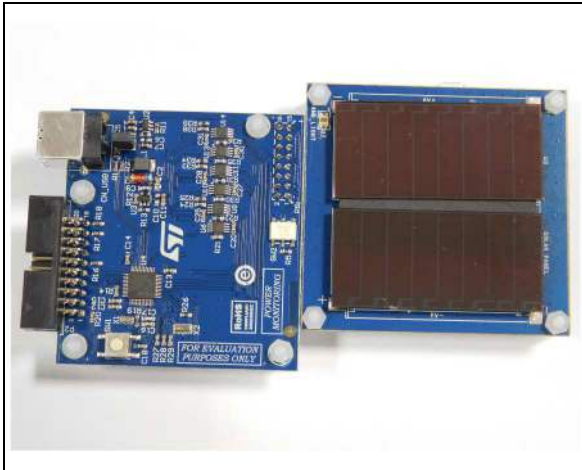

Features

- SPV1050 based harvesting dongle board
- PV module soldered on the back
- Lithium coin cell battery
- PV module electrical characteristics at 200 lux:
 - $V_{OC_TYP} = 9.8\text{ V}$, $I_{SC_TYP} = 20\ \mu\text{A}$
 - $V_{MP_TYP} = 8\text{ V}$, $I_{MP_TYP} = 18\ \mu\text{A}$
- Li-Ion battery:
 - $Capacity_{NOM} = 120\text{ mAh}$
 - $V_{NOMINAL} = 3.6\text{ V}$
 - $V_{CHARGE} = 4.2\text{ V}$
 - $V_{END-OF-DISCHARGE} = 2.75\text{ V}$
- Interface to power monitoring board
- PV module voltage and battery monitoring
- Ambient light sensor for irradiance level measurement
- Supported by SW GUI to show MPPT accuracy and conversion efficiency

Description

The STEVAL-ISV021V1 is a demonstration kit which consists of a complete energy harvesting module based on the SPV1050 ULP energy harvester and battery charger, having the purpose to show the electrical performance of the power converter and many other fundamental electrical quantities related to the overall system.

The power manager is configured as a buck-boost converter, fitting the electrical characteristics of the mounted PV panel and battery.

A power monitoring board along with a software GUI are used to monitor and to graph both of PV panel and battery voltage and current, and system performances like MPPT accuracy and conversion efficiency.

The STEVAL-ISV021V1 represents the standalone harvesting module that can be interfaced with a wireless sensor node to provide the microcontroller, transmitter and sensors with the energy scavenged and stored into the battery.

Furthermore, the STEVAL-ISV021V1 embeds an extension connector to interface and to monitor of some of SPV1050 input and output signals through a microcontroller based board.

1 Schematic and bill of material

The schematic, bill of material and gerber files can be downloaded from the Design resources tab of the STEVAL-ISV021V1 product folder on www.st.com.

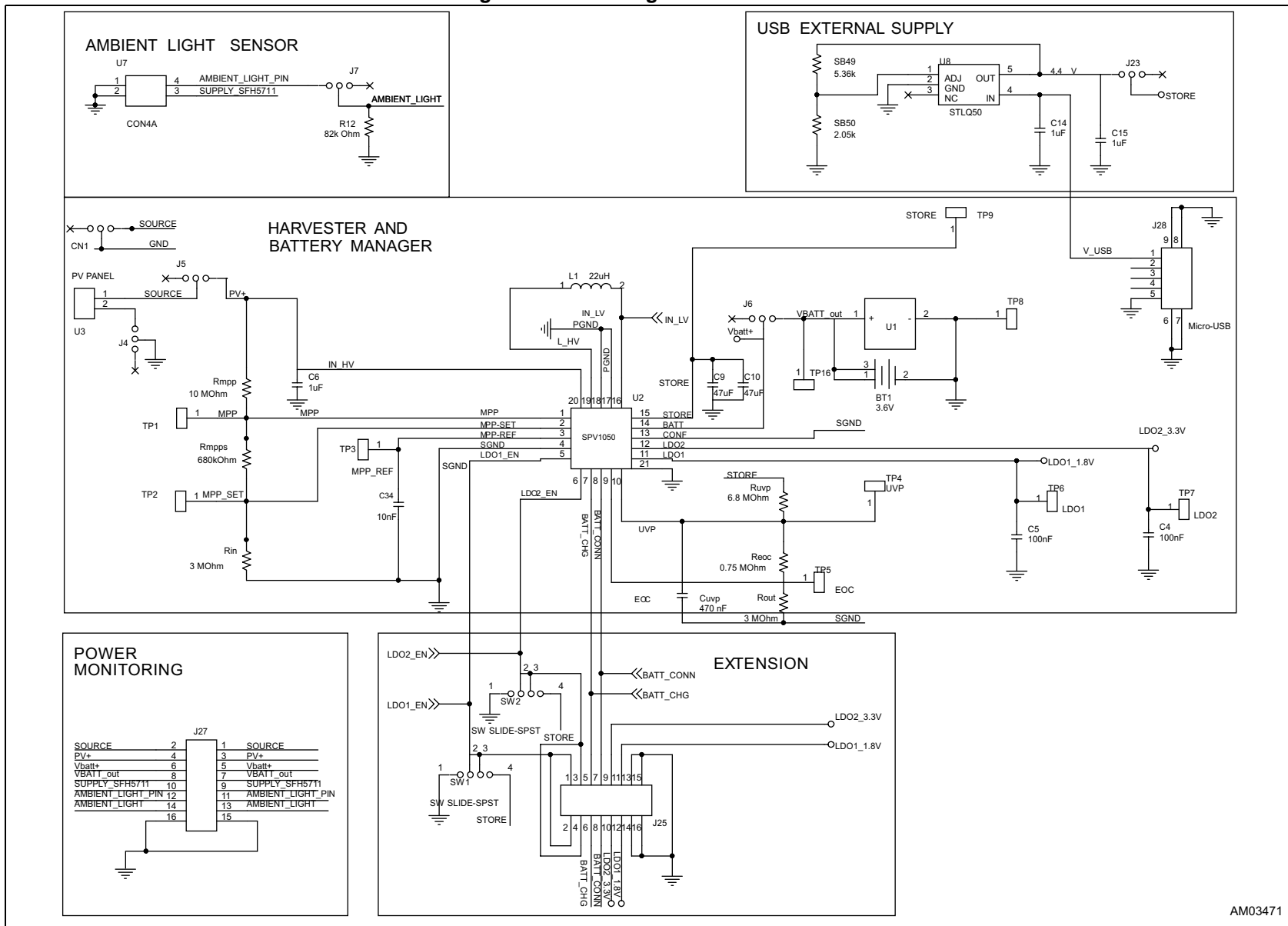
Figure 1. Harvesting module schematic

AM03471



Table 1. Harvesting module BOM

Sect.	Item	Qty.	Ref.	Part/value	Tolerance (%)	Voltage current	Watt	Technol. info.	Package	Manufacturer	Manufacturer code	More information
Battery	1	1	BT1	Support for Li-Ion battery					SMD	Keystone	3008	
	2	1	J6	SMD jumper				Pitch 100 mils	SMD	FCI	95293-101-03LF	This jumper allows the connection of the STORE pin to the voltage regulator U4 in case the external sampling is OFF
Supply	3	2	U3	Flexible PV panel					SMD	SANYO	AM-1801	2 PV panels connected in series
	5	1	J4	SMD jumper				Pitch 100 mils	SMD	FCI	95293-101-03LF	This jumper disconnects the PV panel U3 in case an alternative supply is required and connected to CN1
	6	1	J5	3-way switch				Pitch 100 mils	SMD	FCI	95293-101-03LF	This jumper allows the connection of the source to the harvester U1 in case the external sampling is OFF
	7	1	CN1	2-way conn.				Pitch 100 mils	SMD	FCI	95293-101-03LF	Input connector for external PV panel or TEG



Table 1. Harvesting module BOM (continued)

Sect.	Item	Qty.	Ref.	Part/value	Tolerance (%)	Voltage current	Watt	Technol. info.	Package	Manufacturer	Manufacturer code	More information	
Harvester/DC-DC controller section	MPPT section	8	1	U2	SPV1050					ST		Harvester and thin film battery manager	
		9	1	C6	1 μ F	15%	25 V		X5R	0603	Murata	GRM188R61E105KA12D	Input capacitance
		10	1	Rmpp	10 M Ω	1%		0.1		0603	VISHAY	CRCW060310M0FKEA	Resistor partitioning for MPP track
		11	1	Rmpps	680 k Ω	1%		0.1		0603	TE Connectivity	CRG0603F680K	Resistor partitioning for MPP setting
		12	1	Rin	3 M Ω	0.01				0603	VISHAY	CRCW06033M00FKEA	Input resistor partitioning
		13	1	C34	10 nF	15%	16 V		X7R	0603	Murata	GRM188R71C103KA01D	Voltage sampling time constant capacitance
		14	1	L1	22 μ H	20%					Coilcraft	LPS4018-223ML_ LPS5010-223ML_ XFL2006-223ME_	DC-DC inductor
	LDO1	15	1	SW1	3-way switch				Pitch 100 mils	SMD	FCI	95293-101-04LF	Close 1 - 2, LDO1 is disabled Close 2 - 3, LDO1 controlled by external signal
		16	1	C5	100 nF	10%	6.3 V		X5R	0402	AVX	04026D104KAT2A	
	LDO2	17	1	SW2	3-way switch				Pitch 100 mils	SMD	FCI	95293-101-04LF	Close 1 - 2, LDO2 is disabled Close 2 - 3, LDO2 controlled by external signal
		18	1	C4	100 nF	10%	6.3 V		X5R	0402	AVX	04026D104KAT2A	



Table 1. Harvesting module BOM (continued)

Sect.	Item	Qty.	Ref.	Part/value	Tolerance (%)	Voltage current	Watt	Technol. info.	Package	Manufacturer	Manufacturer code	More information
Battery management section	19	2	C9, C10	47 μ F	20%	6.3 V		X5R	0805	KEMET	C0805C476M9PAC7800	Capacitor on STORE net
	21	1	Cuvp	470 nF	15%	10 V		X5R	0603	Murata	GRM188R71A474KA61D	UVP voltage sampling delay time constant capacitance
	22	1	Ruvp	6.8 M Ω	1%				0603	VISHAY	CRCW06036M80FKEA	VEOC = 4.15 V VUVP = 3.75 V
	23	1	Reoc	0.75 M Ω	1%				0603	VISHAY	CRCW0603750KFKEA	
	24	1	Rout	3 M Ω	1%				0603	VISHAY	CRCW06033M00FKEA	
Ambient light	25	1	U7	SFH5711					SMD	OSRAM	SFH 5711	Ambient light sensor: place on the same solder side of the PV panel (U3)
	26	1	R12	80 k Ω	1%		0.1		0603	VISHAY	CRCW060382K0FKEA	
	27	1	J7	SMD jumper				Pitch 100 mils	SMD	FCI	95293-101-03LF	
External supply from USB	28	1	U8	STLQ50C-R					SOT323-5L	ST	STLQ50C-R	
	29	1	SB49	5.36 k Ω			0.1		0603	Panasonic	ERA3AEB5361V	
	30	1	SB50	2.05 k Ω	\pm 1%		0.1		0603	VISHAY	CRCW06032K05FKEA	
	31	2	C14, C15	1 μ F	15%	25 V		X5R	0603	Murata	GRM188R61E105KA12D	
	33	1	J23	SMD jumper				Pitch 100 mils	SMD	FCI	95293-101-03LF	Disable charging from USB



Table 1. Harvesting module BOM (continued)

Sect.	Item	Qty.	Ref.	Part/value	Tolerance (%)	Voltage current	Watt	Technol. info.	Package	Manufacturer	Manufacturer code	More information
External connections	34	1	J28	Micro-USB					SMD	Molex	47346-0001	External charge from USB
	35	1	J25	16-pin conn.				2.54 mm	SDM	Samtec	SMH-108-02-G-D	Connector for future extensions
	36	1	J27	16-pin conn.				2.54 mm	SMD	Samtec	SMH-108-02-G-D	Connector for power monitoring board
Spacers + nuts	37	4	Screw support							RS	325-687 and 525-701	

2 Layout

Figure 2. Layout - top view

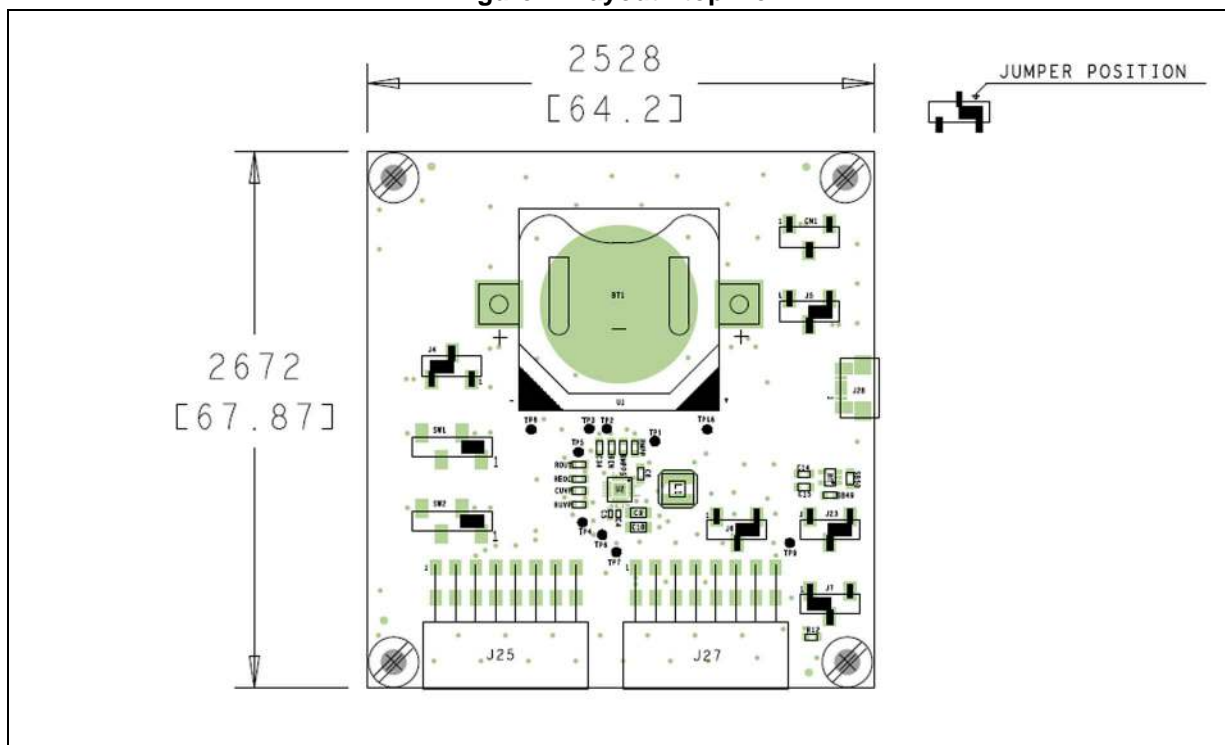
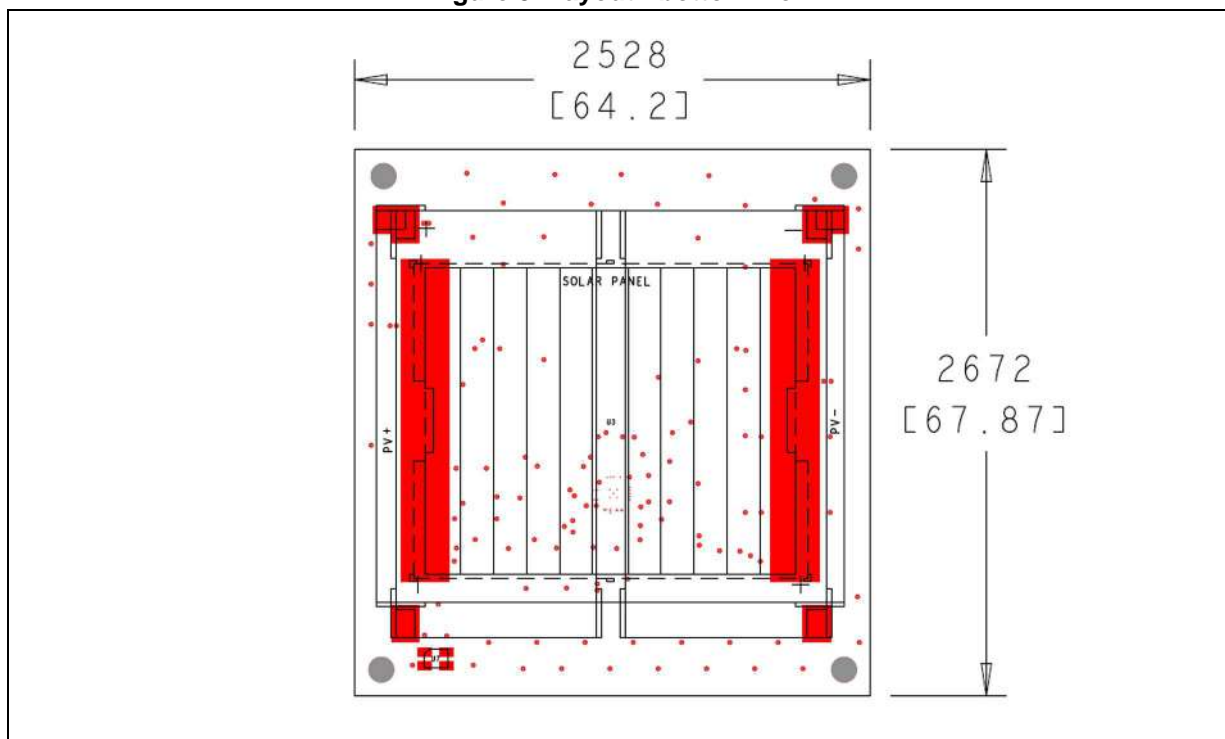

Figure 3. Layout - bottom view



3 Revision history

Table 2. Document revision history

Date	Revision	Changes
28-Nov-2013	1	Initial release.
02-May-2014	2	Updated board photography on page 1 (replaced by new photography). Updated Section 1: Schematic and bill of material on page 2 (updated web link). Updated Table 1: Harvesting module BOM on page 4 (updated item numbering, added manufacturer code to "Screw support" item, updated "More information" for several items).
18-Dec-2015	3	Updated board photo on the cover page.

IMPORTANT NOTICE – PLEASE READ CAREFULLY

STMicroelectronics NV and its subsidiaries ("ST") reserve the right to make changes, corrections, enhancements, modifications, and improvements to ST products and/or to this document at any time without notice. Purchasers should obtain the latest relevant information on ST products before placing orders. ST products are sold pursuant to ST's terms and conditions of sale in place at the time of order acknowledgement.

Purchasers are solely responsible for the choice, selection, and use of ST products and ST assumes no liability for application assistance or the design of Purchasers' products.

No license, express or implied, to any intellectual property right is granted by ST herein.

Resale of ST products with provisions different from the information set forth herein shall void any warranty granted by ST for such product.

ST and the ST logo are trademarks of ST. All other product or service names are the property of their respective owners.

Information in this document supersedes and replaces information previously supplied in any prior versions of this document.

© 2015 STMicroelectronics – All rights reserved