

**Order Number  
63904-3700**

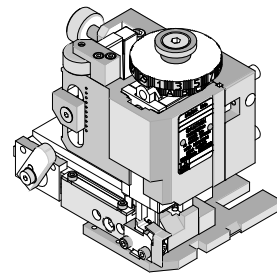

## Application Tooling Specification

### FEATURES

- Directly adapts to most automatic wire processing machines
- Quick punch removal with the push of a button for fast and easy tooling change
- Applicator designed to industry-standard mounting and 135.80mm (5.346") shut height
- Quick setup time; plus, the crimp height, track and feed adjustments can be set without removing the applicator from the press
- Fine adjustment allows users to achieve target with little effort by adjusting in increments of 0.015mm (.0006") for conductor crimp height and 0.063mm (.0025") for insulation height
- Independent adjustment rings allow users to quickly adjust the conductor or insulation crimp height without affecting each other

### SCOPE

**Products:** Mega-Fit Male and Female Terminals, 12 AWG UL1015 Wire.

Terminal Series No.	Terminal Order No.	Wire Size AWG	Insulation Diameter				Strip Length	
			IPC/WHMA-A-620 (1)		Terminal Maximum (2)		mm	In.
			mm	In.	mm	In.		
76823	76823-0343	12	3.75-4.05	.148-.159	4.05	.159	5.00-5.50	.197-.216
105417	105417-0333	12	3.75-4.05	.148-.159	4.05	.159	5.00-5.50	.197-.216
105418	105418-0313	12	3.75-4.05	.148-.159	4.05	.159	5.00-5.50	.197-.216
	105418-1313							
172063	172063-0333	12	3.75-4.05	.148-.159	4.05	.159	5.00-5.50	.197-.216
	172063-1333							

(1) To achieve optimum IPC/WHMA-A-620 insulation crimps, use this OD range or UL1015 wire type  
 (2) Overall insulation OD specification for terminal

### DEFINITION OF TERMS

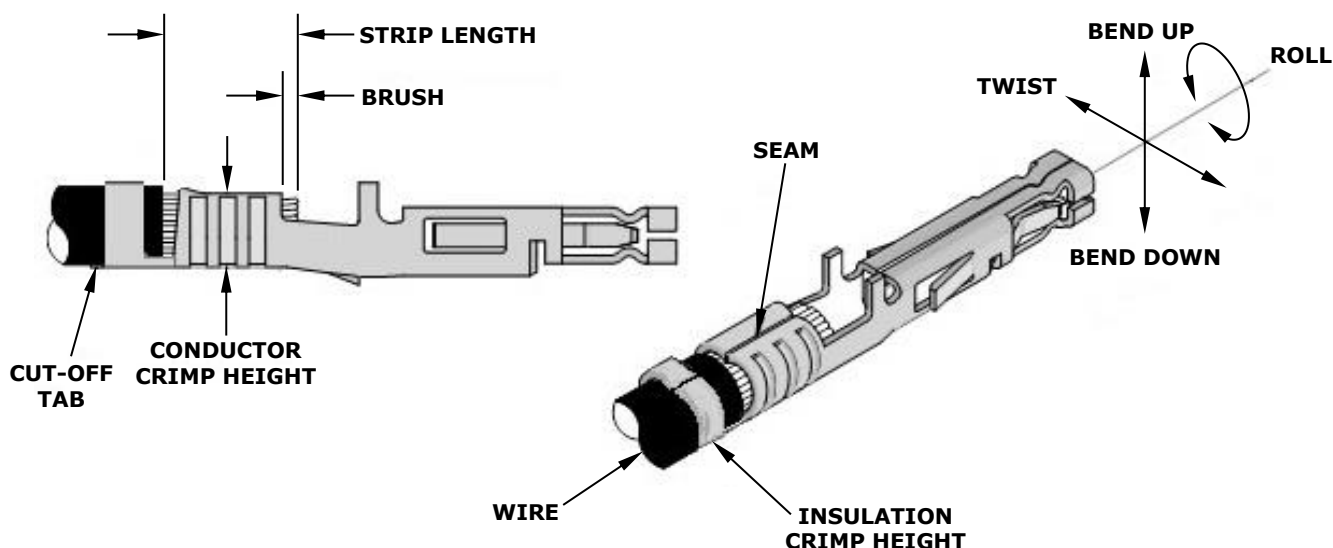

**CRIMP SPECIFICATION**

Terminal Series No.	Bell Mouth		Cut-Off Tab Maximum		Conductor Brush	
	mm	In.	mm	In.	mm	In.
76823	0.40-0.75	.016-.029	0.60	.024	0.10-1.15	.004-.045
105417	0.40-0.75	.016-.029	0.60	.024	0.10-1.15	.004-.045
105418	0.40-0.75	.016-.029	0.60	.024	0.10-1.15	.004-.045
172063	0.40-0.75	.016-.029	0.60	.024	0.10-1.15	.004-.045

Terminal Series No.	Bend Up	Bend Down	Twist	Roll	Punch Width (Ref)		Seam
	Degree (Max)		Degree (Max)		Conductor		
					mm	In.	
76823	3	3	4	8	3.20	.126	Seam shall not be open and no wire allowed out of the crimping area
105417	3	3	4	8	3.20	.126	
105418	3	3	4	8	3.20	.126	
172063	3	3	4	8	3.20	.126	

After crimping, the conductor profile should measure the following:

Terminal Series No.	Wire Size	Conductor Crimp				Pull Force Minimum	
		Crimp Height		Crimp Width (Ref)		N	Lb.
	AWG	mm	In.	mm	In.		
76823	12	1.90-2.00	.075-.079	3.30	.130	220.0	49.46
105417	12	1.90-2.00	.075-.079	3.30	.130	220.0	49.46
105418	12	1.90-2.00	.075-.079	3.30	.130	220.0	49.46
172063	12	1.90-2.00	.075-.079	3.30	.130	220.0	49.46

Terminal Series No.	Wire Size	Insulation Crimp			
		Crimp Height (Ref)		Crimp Width (Ref)	
	AWG	mm	In.	mm	In.
76823	12	4.10	.161	4.60	.181
105417	12	4.10	.161	4.60	.181
105418	12	4.10	.161	4.60	.181
172063	12	4.10	.161	4.60	.181

**Tool Qualification Notes**

1. Pull force should be measured with no influence from the insulation crimp.
2. The above specifications are guidelines to an optimum crimp.
3. Oiler (63801-7240) required to crimp terminals to improve tooling life and also to minimize the crimp extrusions. See 63800-4900 FineAdjust manual.

## NOTES

---

1. Molex recommends that an extra perishable tooling kit be maintained at your facility.
2. Verify tooling alignment by hand cycling the press and applicator before crimping under power. Check that all screws are tight.
3. Slugs, terminals, dirt and oil should be kept clear of the work area.
4. Wear safety glasses at all times.
5. For recommended maintenance, refer to the FineAdjust manual.

## WARNINGS

---

**CAUTION:** This applicator must be installed in a press with a standard shut height of 135.80mm (5.346"). Tooling damage could result at a lower setting.

**CAUTION:** To prevent injury, never operate this applicator without the guards supplied with the press or wire-processing machine in place. Reference the press or wire processing manufacturer's instruction manual.

**CAUTION:** Molex tooling crimp specifications are valid only when used with Molex terminals and tooling manufactured by Molex and sold by Molex or authorized distributors ("Molex Tooling"). When using tooling other than Molex Tooling with Molex-specific connector systems listed in our ATS documents, the Molex Tooling qualification does not apply, and the responsibility for full qualification of the connector system is that of the customer. Molex accepts no liability for connector performance or tooling support where tooling other than Molex Tooling is used or where Molex Tooling is modified.

**PARTS LIST**

<b>FineAdjust Applicator 63904-3700</b>				
<b>Item</b>	<b>Order No.</b>	<b>Engineering No.</b>	<b>Description</b>	<b>Quantity</b>
<b>Perishable Tooling</b>				
	63904-3770	63904-3770	Tool Kit (All "Y" Items)	REF
1	63457-3201	63457-3201	Conductor Punch	1 Y
2	63455-3231	63455-3231	Conductor Anvil	1 Y
3	63454-0110	63454-0110	Insulation Punch	1 Y
4	63445-4532	63445-4532	Insulation Anvil	1 Y
5	63443-0002	63443-0002	Cut-Off Plunger	1 Y
6	63443-0012	63443-0012	Front Plunger Retainer	1 Y
<b>Other Components</b>				
7	11-17-0022	1739-21	Nose Hold Down Spring	1
8	11-18-4083	60707-8	Feed Guide	1
9	11-24-1067	4996-4	Cut-Off Plunger Spring	1
10	63443-0009	63443-0009	Scrap Chute	1
11	63443-0024	63443-0024	Key	1
12	63443-0090	63443-0090	Wire Stop	1
13	63443-0093	63443-0093	Shank	1
14	63443-1715	63443-1715	18.50mm (Height Spacer)	1
15	63443-2314	63443-2314	3.70mm (Fine Spacer)	1
16	63443-2208	63443-2208	8.00mm (Coarse Spacer)	1
17	63443-2205	63443-2205	5.00mm (Coarse Spacer)	1
18	63443-3160	63443-3160	Front Plunger Striker	1
19	63443-6123	63443-6123	Rear Cover	1
20	63443-7136	63443-7136	Terminal Hold Down	1
<b>Frame</b>				
21	63800-4901	63800-4901	Top	1
22	63801-3281	63801-3281	Base	1
23	63801-4650	63801-4650	Track	1
<b>Hardware</b>				
24	—	—	M3 by 6 Long SHCS	2*
25	—	—	M3 by 6 Long FHCS	1*
26	—	—	M3 by 8 Long SHCS	1*
27	—	—	M4 by 6 Long SHCS	2*
28	—	—	M4 by 12 Long BHCS	2*
29	—	—	M4 by 45 Long SHCS	2*
30	—	—	M5 by 12 Long SHCS	1*
31	—	—	#10-32 by 3/8" Long Flat Point SSS	1*
32	—	—	#10-32 Hex Jam Nut	1*

\* Available from an industrial supply company.

**ASSEMBLY DRAWING**

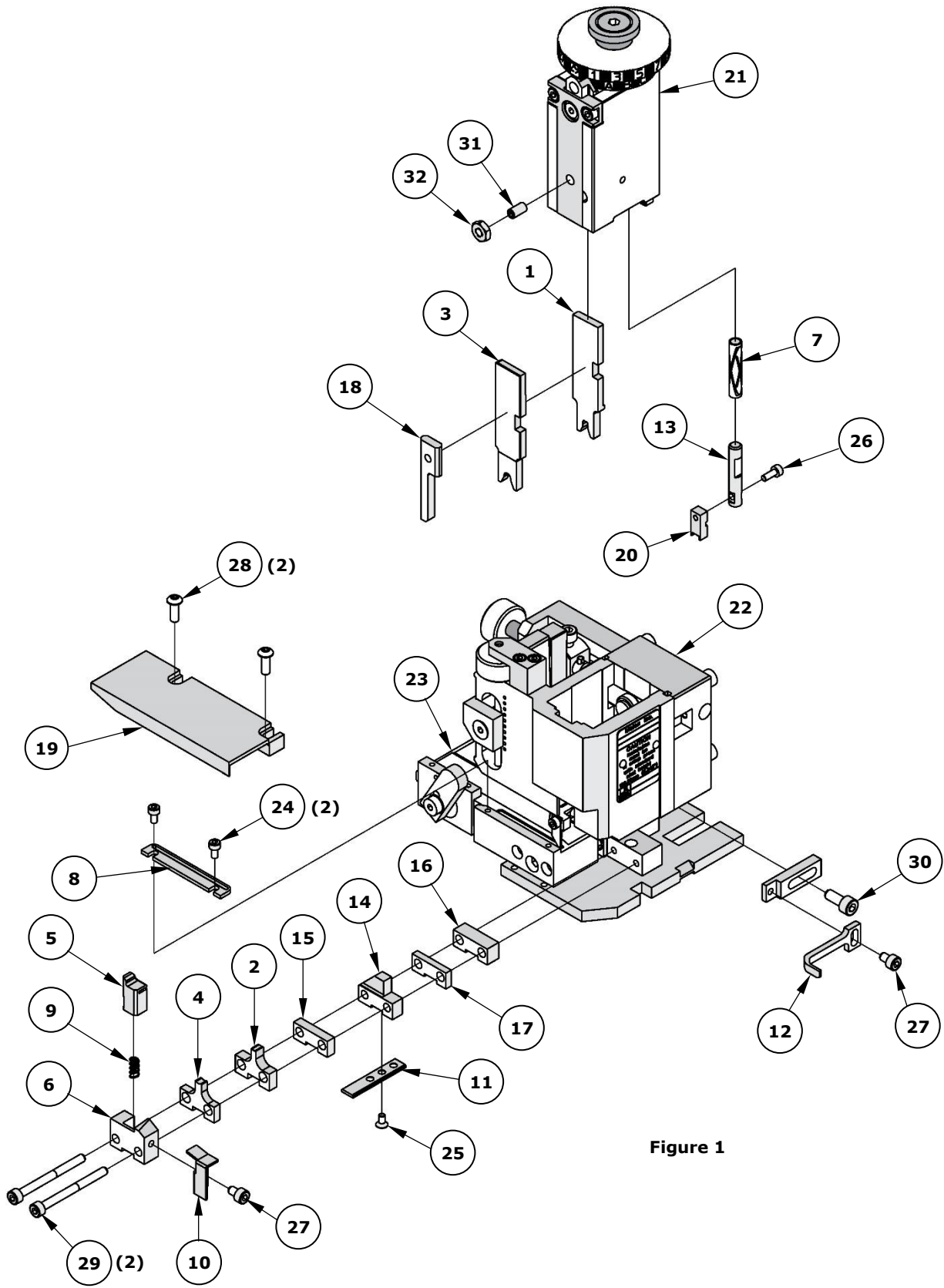

Figure 1

**Application Tooling Support**

**Phone:** (402) 458-TOOL (8665)

**E-Mail:** [applicationtooling@molex.com](mailto:applicationtooling@molex.com)

**Website:** [www.molex.com/applicationtooling](http://www.molex.com/applicationtooling)

Molex is a registered trademark of Molex, LLC in the United States of America and may be registered in other countries; all other trademarks listed herein belong to their respective owners.