

PRODUCT NUMBER
SEE TABLE

NOTES:

① PRODUCT NUMBERING CODE:
50006 - X YYY Z LF
LEAD FREE (OPTIONAL)
TAIL LENGTH SEE TABLE
NO. OF POSITIONS SEE NOTE 2
PLATING SEE TABLE
BASE NUMBER

PRODUCT NUMBERING CODE FOR
SELECT LOAD PART NUMBERS:
50006 - XX YYY LF
LEAD FREE(OPTIONAL)
SEQUENCE NUMBER
ALWAYS 'XX'
BASE NUMBER

- ② THIS PRODUCT IS CONFIGURED IN SIZES OF 6 thru 80 COLUMNS IN INCREMENTS OF ONE. i.e.: 6,7,8,9,.....79,80.
- ③ HOUSING MATERIAL: GLASS AND MINERAL FILLED HIGH TEMP. THERMOPLASTIC. FLAME RETARDANT PER UL94V-0. COLOR: BLACK. PIN MATERIAL: PHOS BRONZE
- ④ CONTACT PLATING OPTIONS: SEE PRODUCT NUMBER TABLE
- ⑤ $\phi.0453/1.151$ DRILLED HOLE PLATED WITH $.0003/.007$ MIN. SnPb OVER $.001/.03$ to $.003/.08$ Cu. PLATING TO ACHIEVE A $\phi.040\pm.003/1.02\pm.08$ HOLE.
- ⑥ TO ASSURE PROPER INSTALLATION: TOOLING, AS SPECIFIED IN INSTRUCTION MANUAL 155915-001 MUST BE USED. PIN MATING LENGTH WILL BE $\pm.002/.05$ AFTER INSTALLATION.
- ⑦ COMPANY NAME, PART NUMBER AND LOT CODE TO APPEAR ON THIS SURFACE PER BUS-12-108.
- ⑧ DIM "A" CALCULATION = $.100[2.54] \times \text{NO. OF COLUMNS} + .75[19.1]$
- ⑨ DIM "B" CALCULATION = $.100[2.54] \times \text{NO. OF COLUMNS} + .450[11.43]$
- ⑩ DIM "C" CALCULATION = $.100[2.54] \times \text{NO. OF COLUMNS} - .100[2.54]$
- 11. ALL POSITIONS ARE LOADED EXCEPT FOR -XXYYY ASSEMBLIES WHICH HAVE SELECTIVE LOADING.
- ⑫ REFERENCE 50807 FOR F.M.L.B. AVAILABLE OPTIONS AND WORKSHEET.
- 13. THIS PRODUCT (WITH 'LF' SUFFIX) MEETS EUROPEAN UNION DIRECTIVES AND OTHER COUNTRY REGULATIONS AS DESCRIBED IN GS-22-008.
- 14. THIS HOUSING WILL WITHSTAND EXPOSURE TO 260°C PEAK TEMPERATURE FOR 10-30 SECONDS IN A CONVECTION, INFRA-RED OR VAPOR PHASE REFLOW OVEN.

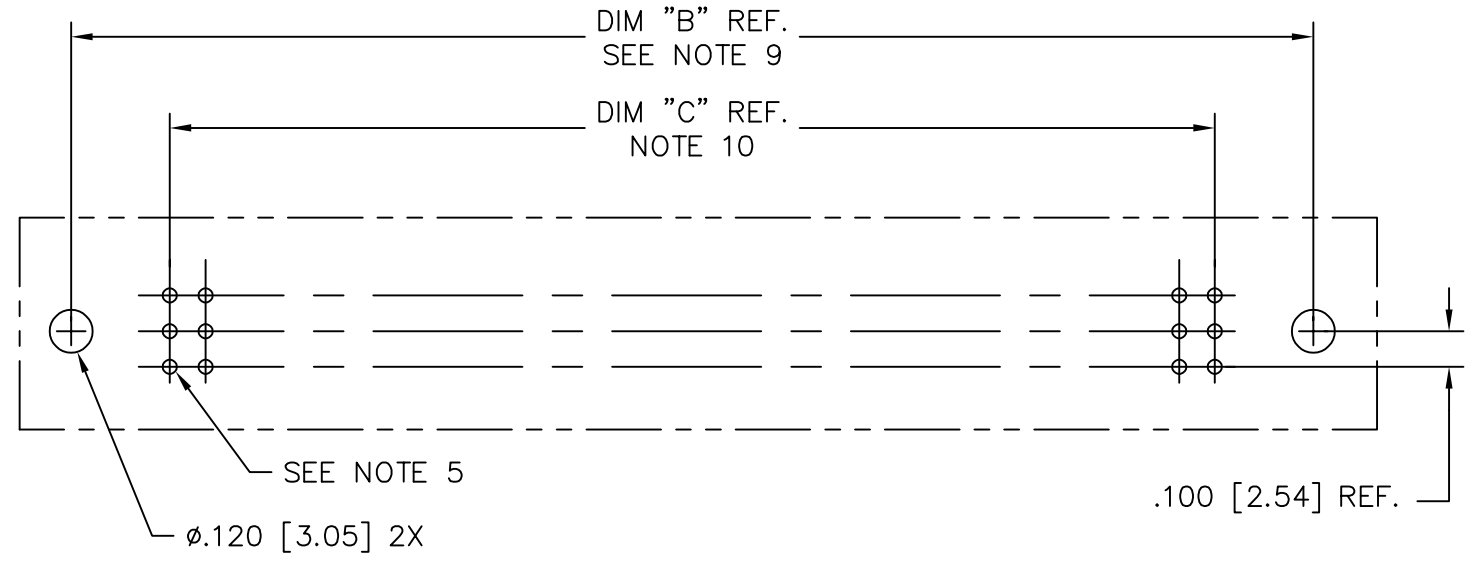
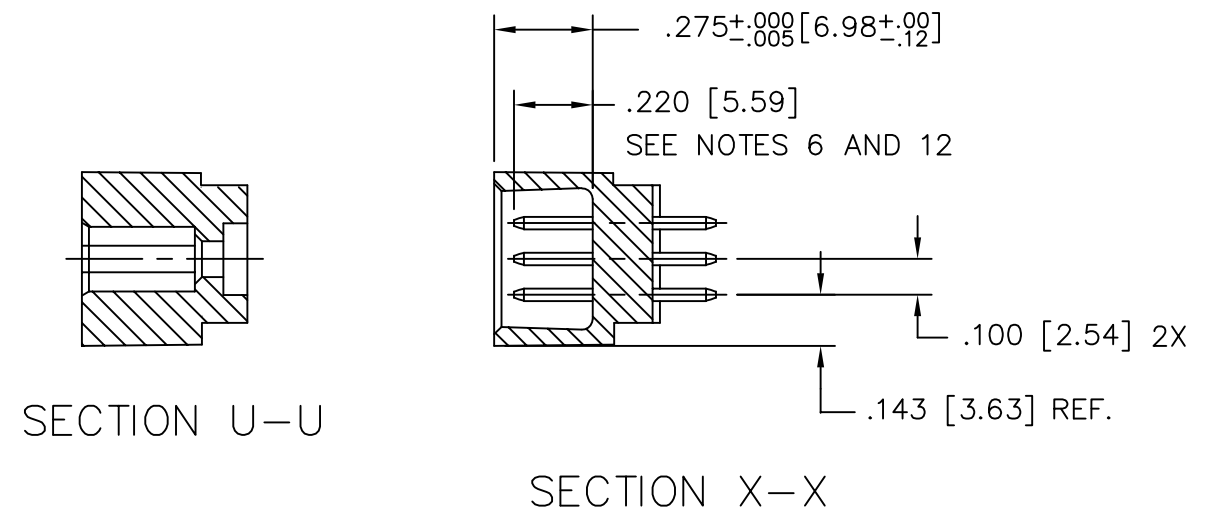

RECOMMENDED PCB LAYOUT
(ALL HOLES LOCATED ON $.100/2.54$ GRID UNLESS OTHERWISE SPECIFIED)

mat'l. code SEE NOTE 3				surface ISO 1302 ✓		tolerance ISO 406 ISO 1101		projection 		product family HPC			
ltr	ecn no	dr	date	tolerances unless otherwise specified						title			
P				angles		linear		INCH/MM		3 ROW VERTICAL HEADER W/PRESS-FIT PINS, 0 G.P.			
				0°±2'				scale 1:1		dwg no		sheet 2 of 17 size	
				dr	D.SHEAFER	1991-03-14		Amphenol FCi		50006		A3	
			enr	S.CLARK	1991-03-14								
			chr	S ALOSIUS	2011-05-23								
			appd	BIJU K PAUL	2011-05-23								
sheet index		revision sheet								type Product Customer Drawing			

PRODUCT NO.	NUMBER OF POSITIONS NOTE 2	TAIL LENGTH ±.015/0.38	CONTACT PLATING
50006-1YYYYA	YYY	.177/4.50	30u"/.76u GOLD
50006-1YYYC	YYY	.533/13.54	30u"/.76u GOLD
50006-1YYVD	YYY	.733/18.62	30u"/.76u GOLD
50006-1YYYG	YYY	.250/6.35	30u"/.76u GOLD
50006-1YYYL	YYY	.188/4.78	30u"/.76u GOLD
50006-1YYYP	YYY	.470/11.94	30u"/.76u GOLD
50006-3YYYYA	YYY	.177/4.50	50u"/1.27u GOLD
50006-3YYYC	YYY	.533/13.54	50u"/1.27u GOLD
50006-3YYVD	YYY	.733/18.62	50u"/1.27u GOLD
50006-3YYYG	YYY	.250/6.35	50u"/1.27u GOLD
50006-3YYYL	YYY	.188/4.78	50u"/1.27u GOLD
50006-3YYYP	YYY	.470/11.94	50u"/1.27u GOLD
50006-5YYYYA	YYY	.177/4.50	30u"/.76u GXT
50006-5YYYALF	YYY	.177/4.50	30u"/.76u GXT
50006-5YYYC	YYY	.533/13.54	30u"/.76u GXT
50006-5YYYCLF	YYY	.533/13.54	30u"/.76u GXT
50006-5YYVD	YYY	.733/18.62	30u"/.76u GXT
50006-5YYVDLF	YYY	.733/18.62	30u"/.76u GXT
50006-5YYYG	YYY	.250/6.35	30u"/.76u GXT
50006-5YYYGLF	YYY	.250/6.35	30u"/.76u GXT
50006-5YYYL	YYY	.188/4.78	30u"/.76u GXT
50006-5YYYLLF	YYY	.188/4.78	30u"/.76u GXT
50006-5YYYP	YYY	.470/11.94	30u"/.76u GXT
50006-5YYYPLF	YYY	.470/11.94	30u"/.76u GXT
50006-XX010	150	SEE SHEET 4	30u"/.76u GXT
50006-XX010LF	150	SEE SHEET 4	30u"/.76u GXT
50006-XX025	18	SEE SHEET 5	30u"/.76u GXT
50006-XX025LF	18	SEE SHEET 5	30u"/.76u GXT
50006-XX027	96	SEE SHEET 6	30u"/.76u GOLD
50006-XX027LF	96	SEE SHEET 6	30u"/.76u GXT
50006-XX028	30	SEE SHEET 7	30u"/.76u GOLD
50006-XX028LF	30	SEE SHEET 7	30u"/.76u GXT
50006-XX045	180	SEE SHEET 8	30u"/.76u GXT
50006-XX045LF	180	SEE SHEET 8	30u"/.76u GXT
50006-XX049	96	SEE SHEET 9	30u"/.76u GOLD
50006-XX049LF	96	SEE SHEET 9	30u"/.76u GXT
50006-XX053	150	SEE SHEET 10	30u"/.76u GXT
50006-XX053LF	150	SEE SHEET 10	30u"/.76u GXT
50006-XX054	150	SEE SHEET 11	30u"/.76u GOLD
50006-XX054LF	150	SEE SHEET 11	30u"/.76u GXT
50006-XX055	30	SEE SHEET 12	30u"/.76u GOLD
50006-XX055LF	30	SEE SHEET 12	30u"/.76u GXT
50006-XX056	150	SEE SHEET 13	30u"/.76u GOLD
50006-XX056LF	150	SEE SHEET 13	30u"/.76u GXT
50006-XX057	150	SEE SHEET 14	30u"/.76u GOLD
50006-XX057LF	150	SEE SHEET 14	30u"/.76u GXT
50006-XX058	240	SEE SHEET 15	50u"/1.27u GOLD
50006-XX058LF	240	SEE SHEET 15	50u"/1.27u GXT
50006-XX059	240	SEE SHEET 16	50u"/1.27u GOLD
50006-XX059LF	240	SEE SHEET 16	50u"/1.27u GXT
50006-XX060LF	165	SEE SHEET 17	30u"/.76u GOLD

mat'l. code SEE NOTE 3		surface ISO 1302 ✓		tolerance ISO 406 ISO 1101		projection 		product family HPC		
ltr	ecn no	dr	date	tolerances unless otherwise specified		INCH/MM		title 3 ROW VERTICAL HEADER W/PRESS-FIT PINS, 0 G.P.		
R				angles	linear	scale 1:1		dwg no 50006		
				0°±2'	.xxx±.005/.13 .xxxx±.0020/.051			sheet 3 of 17 size A3		
				dr	D.SHEAFER	1991-03-14	Amphenol FCi		type Product Customer Drawing	
				enr	S.CLARK	1991-03-14				
				chr	M JACOB	2019-01-03				
				appd	BIJU K PAUL	2019-01-03				
sheet index	revision sheet									

Copyright AFCI

Amphenol FCI

PRODUCT NUMBER
50006-XX010
50006-XX010LF

FOR PRODUCT NUMBERS 50006-XX010 AND 50006-XX010LF ONLY

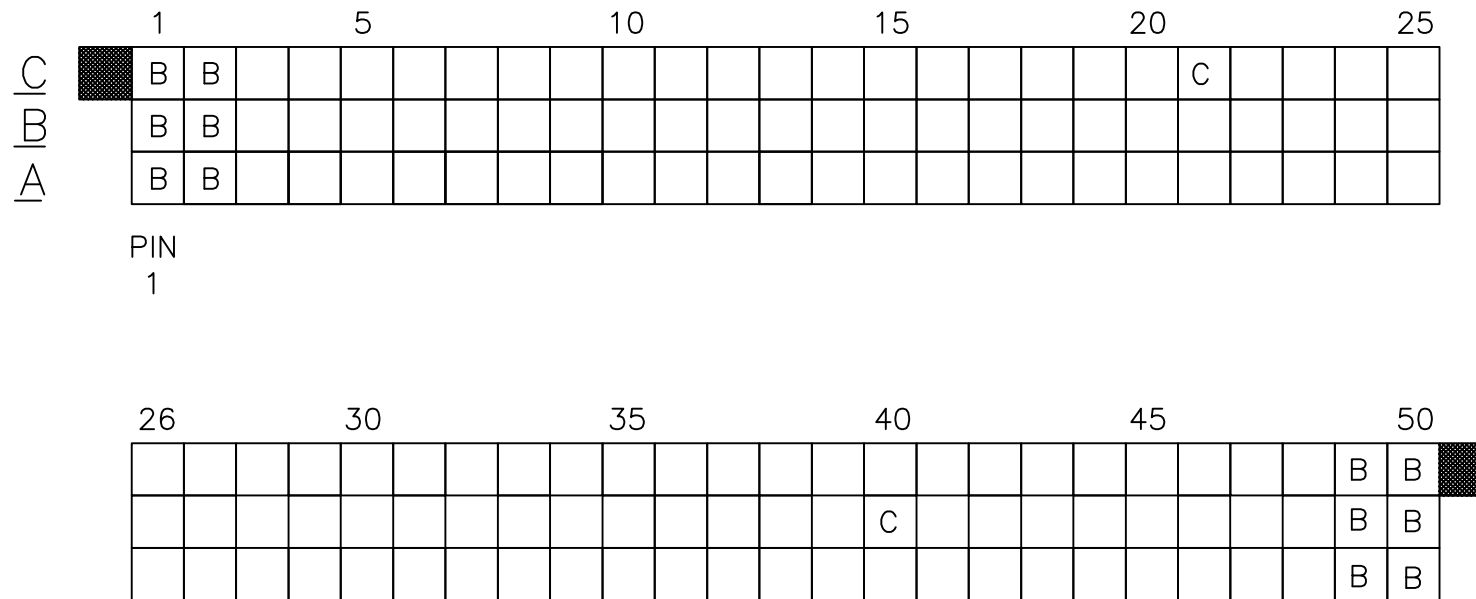

PIN
1

NOTES FOR 50006-XX010 AND 50006-XX010LF ONLY:

- ALL POSITIONS ARE LOADED WITH "A" EXCEPT AS SHOWN.
- COLUMN 1, ROW A IS DESIGNATED AS SIGNAL PIN 1, AS VIEWED FROM THE MATING FACE.
- SIGNAL DATA FOR 50006-XX010 AND 50006-XX010LF:
SIZE 3 x 50
TOTAL NO. OF POSITIONS - 150
NO. OF POSITIONS LOADED - 150

ITEM KEY	QTY.	MATING LENGTH	TAIL LENGTH
A	136	.200 / 5.08	.177 / 4.50
B	12	.200 / 5.08	.533 / 13.54
C	2	.240 / 6.10	.177 / 4.50

mat'l. code		surface ISO 1302 ✓		tolerance ISO 406 ISO 1101		projection 		product family HPC		
ltr	ecn no	dr	date	tolerances unless otherwise specified		INCH/MM		title		
P				angles	linear	.XX±.01/.3 .XXX±.005/.13 .XXXX±.0020/.051		3 ROW VERTICAL HEADER W/PRESS-FIT PINS, 0 G.P.		
				0°±2'		scale 1:1		dwg no		
				dr	D.SHEAFER	1991-03-14			sheet 4 of 17	
				enr	S.CLARK	1991-03-14			50006	A3
				chr	S ALOSIUS	2011-05-23				
				appd	BIJU K PAUL	2011-05-23				
sheet index	revision sheet								type Product Customer Drawing	

PRODUCT NUMBER
50006-XX025
50006-XX025LF

FOR PRODUCT NUMBERS 50006-XX025 AND 50006-XX025LF ONLY

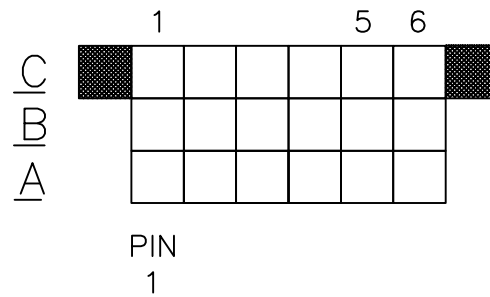

CUSTOMER NOTE: END GUIDE PINS ARE SUGGESTED IN YOUR APPLICATION TO PREVENT STUBBING OF THE .260/6.60 MATING LENGTH SIGNAL PINS.

NOTES FOR 50006-XX025 AND 50006-XX025LF ONLY:

- ALL POSITIONS ARE LOADED WITH "A" .
- COLUMN 1, ROW A IS DESIGNATED AS SIGNAL PIN 1, AS VIEWED FROM THE MATING FACE.
- SIGNAL DATA FOR 50006-XX025 AND 50006-XX025LF:
SIZE 3 x 6
TOTAL NO. OF POSITIONS - 18
NO. OF POSITIONS LOADED - 18

ITEM KEY	QTY.	MATING LENGTH	TAIL LENGTH
A	18	.260 / 6.60	.533 / 13.54

mat'l. code		surface ISO 1302 ✓		tolerance ISO 406 ISO 1101		projection 		product family HPC	
ltr	ecn no	dr	date	tolerances unless otherwise specified		INCH/MM		title	
P				angles	linear	scale 1:1		3 ROW VERTICAL HEADER W/PRESS-FIT PINS, 0 G.P.	
				0°±2'	.XX±.01/.3 .XXX±.005/.13 .XXXX±.0020/.051			dwg no	
				dr	D.SHEAFER	1991-03-14	Amphenol FCi		sheet 5 of 17
				enr	S.CLARK	1991-03-14	50006		A3
				chr	S ALOSIOUS	2011-05-23	Product Customer Drawing		
				appd	BIJU K PAUL	2011-05-23			
sheet index	revision sheet								

PRODUCT NUMBER
50006-XX027
50006-XX027LF

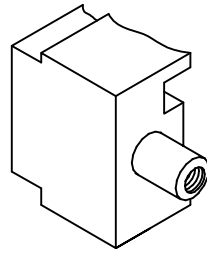

L.E.

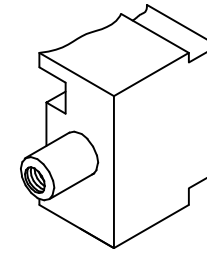

R.E.

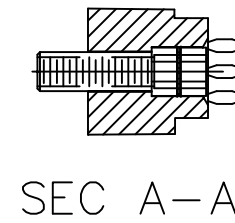
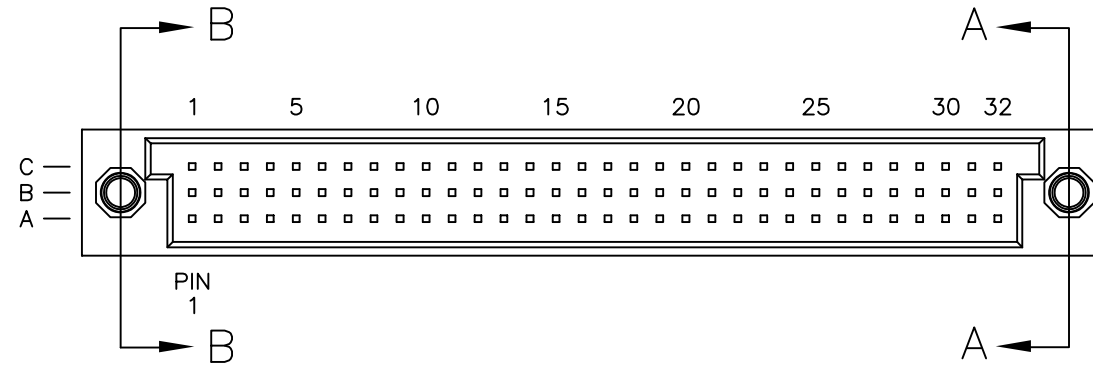
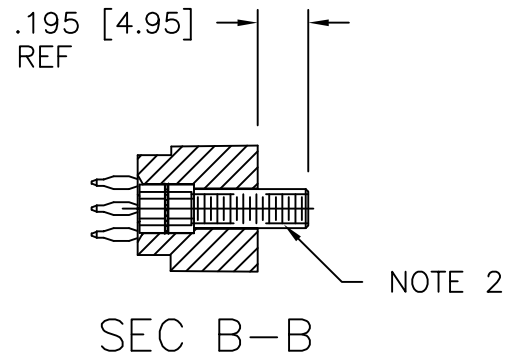

FOR PRODUCT NUMBERS 50006-XX027 AND 50006-XX027LF

NOTES:

1. IDENTICAL TO P/N 50006-1096A EXCEPT AS SHOWN W/JACK SCREW INSERTS INSTALLED ON BOTH ENDS.
2. HARDWARE P/N 95729-001.

mat'l. code		surface ISO 1302 ✓		tolerance ISO 406 ISO 1101		projection 		product family HPC	
ltr	ecn no	dr	date	tolerances unless otherwise specified		INCH/MM		title	
P				angles	linear	scale 1:1		3 ROW VERTICAL HEADER W/PRESS-FIT PINS, 0 G.P.	
				0°±2'	.XX±.01/.3 .XXX±.005/.13 .XXXX±.0020/.051			dwg no	
				dr	D.SHEAFER	1991-03-14	Amphenol FCi		sheet 6 of 17
				enr	S.CLARK	1991-03-14	50006		A3
				chr	S ALOSIUS	2011-05-23	Product Customer Drawing		
				appd	BIJU K PAUL	2011-05-23			
sheet index	revision sheet								

PRODUCT NUMBER
50006-XX028
50006-XX028LF

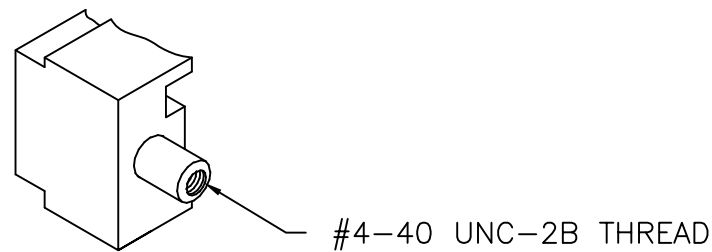

L.E.

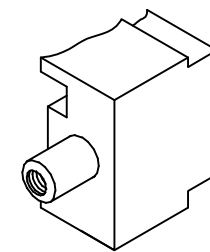

R.E.

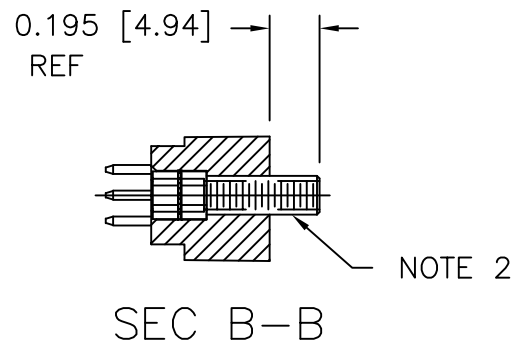

SEC B-B

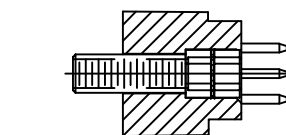
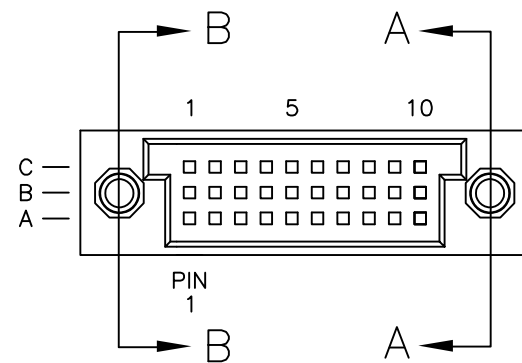

SEC A-A

FOR PRODUCT NUMBERS 50006-XX028 AND 50006-XX028LF

NOTES:

1. IDENTICAL TO P/N 50006-1030A EXCEPT AS SHOWN W/JACK SCREW INSERTS INSTALLED ON BOTH ENDS.
2. HARDWARE P/N 95729-001.

mat'l. code		surface ISO 1302 ✓		tolerance ISO 406 ISO 1101		projection 		product family HPC	
ltr	ecn no	dr	date	tolerances unless otherwise specified		INCH/MM scale 1:1		title	
P				angles	linear			3 ROW VERTICAL HEADER W/PRESS-FIT PINS, 0 G.P.	
				0°±2'	.XX±.01/.3 .XXX±.005/.13 .XXXX±.0020/.051	Amphenol FCi		dwg no 50006	
				dr	D.SHEAFER 1991-03-14			sheet 7 of 17 size A3	
				enr	S.CLARK 1991-03-14			type Product Customer Drawing	
				chr	S ALOSIUS 2011-05-23				
				appd	BIJU K PAUL 2011-05-23				
sheet index	revision sheet								

PRODUCT NUMBER
50006-XX045
50006-XX045LF

FOR PRODUCT NUMBERS 50006-XX045 AND 50006-XX045LF ONLY

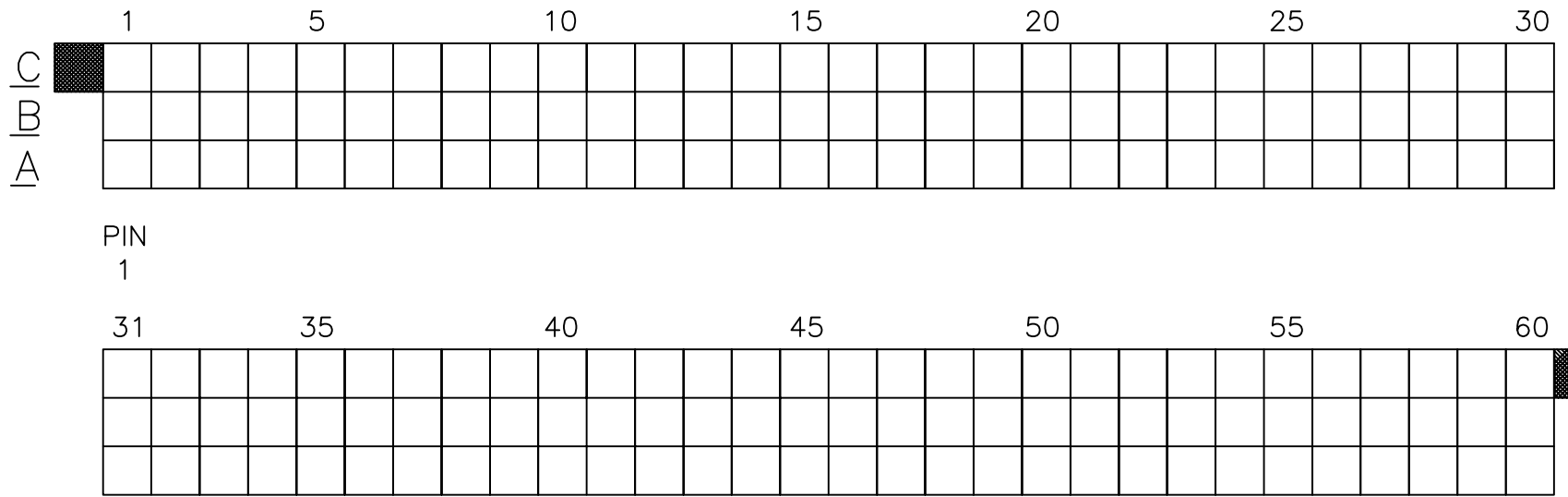

NOTES FOR 50006-XX045 AND 50006-XX045LF ONLY:

- ALL POSITIONS ARE LOADED WITH "A".
- COLUMN 1, ROW A IS DESIGNATED AS SIGNAL PIN 1, AS VIEWED FROM THE MATING FACE.
- SIGNAL DATA FOR 50006-XX045 AND 50006-XX045LF:
 SIZE 3 x 60
 TOTAL NO. OF POSITIONS - 180
 NO. OF POSITIONS LOADED - 180

ITEM KEY	QTY.	MATING LENGTH	TAIL LENGTH
A	180	.220 - 5.59	.597 - 15.16

mat'l. code		surface ISO 1302 ✓		tolerance ISO 406 ISO 1101		projection 		product family HPC		
ltr	ecn no	dr	date	tolerances unless otherwise specified		INCH/MM		title		
P				angles	linear	scale 1:1		3 ROW VERTICAL HEADER W/PRESS-FIT PINS, 0 G.P.		
				0°±2'				dwg no		
								sheet 8 of 17		
				dr	D.SHEAFER	1991-03-14	Amphenol FCi		size	
				enr	S.CLARK	1991-03-14			A3	
				chr	S ALOSIUS	2011-05-23			50006	
				appd	BIJU K PAUL	2011-05-23			Product Customer Drawing	
sheet index	revision sheet									

PRODUCT NUMBER
50006-XX049
50006-XX049LF

FOR PRODUCT NUMBER 50006-XX049 AND 50006-XX049LF ONLY

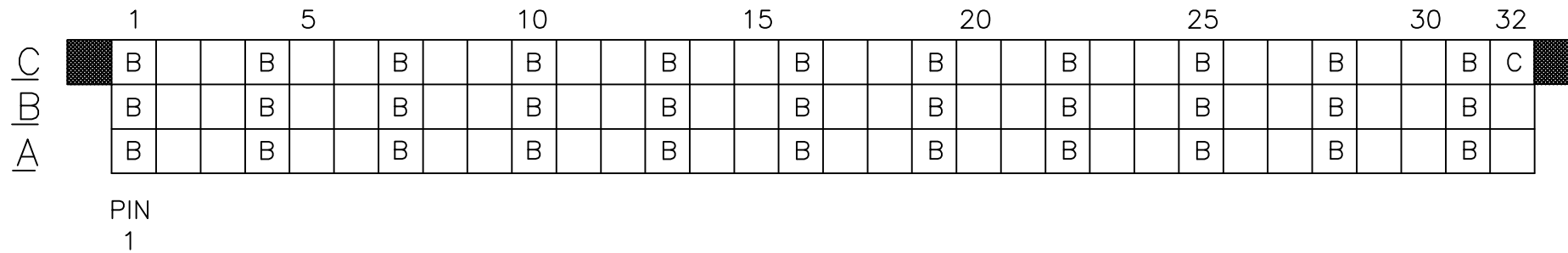

CUSTOMER NOTE: END GUIDE PINS ARE SUGGESTED IN YOUR APPLICATION TO PREVENT STUBBING OF THE .260/6.60 MATING LENGTH SIGNAL PINS.

NOTES FOR 50006-XX049 AND 50006-XX049LF ONLY:

- ALL POSITIONS ARE LOADED WITH "A" EXCEPT AS SHOWN.
- COLUMN 1, ROW A IS DESIGNATED AS SIGNAL PIN 1, AS VIEWED FROM THE MATING FACE.
- SIGNAL DATA FOR 50006-XX049 AND 50006-XX049LF:
 SIZE 3 x 32
 TOTAL NO. OF POSITIONS - 96
 NO. OF POSITIONS LOADED - 96

ITEM KEY	QTY.	MATING LENGTH	TAIL LENGTH
A	62	.220 / 5.59	.177 / 4.50
B	33	.260 / 6.60	.177 / 4.50
C	1	.180 / 4.57	.177 / 4.50

mat'l. code		surface ISO 1302 ✓		tolerance ISO 406 ISO 1101		projection 		product family HPC	
ltr	ecn no	dr	date	tolerances unless otherwise specified		INCH/MM		title	
P				angles	linear	.XX±.01/.3		3 ROW VERTICAL HEADER	
				0°±2'		.XXX±.005/.13		W/PRESS-FIT PINS, 0 G.P.	
						.XXXX±.0020/.051		scale 1:1	
		dr	D.SHEAFER	1991-03-14	Amphenol FCi		dwg no		sheet 9 of 17
		enr	S.CLARK	1991-03-14			50006		A3
		chr	S ALOSIUS	2011-05-23			type		Product Customer Drawing
		appd	BIJU K PAUL	2011-05-23					
sheet index	revision sheet								

PRODUCT NUMBER
50006-XX053
50006-XX053LF

FOR PRODUCT NUMBERS 50006-XX053 AND 50006-XX053LF ONLY

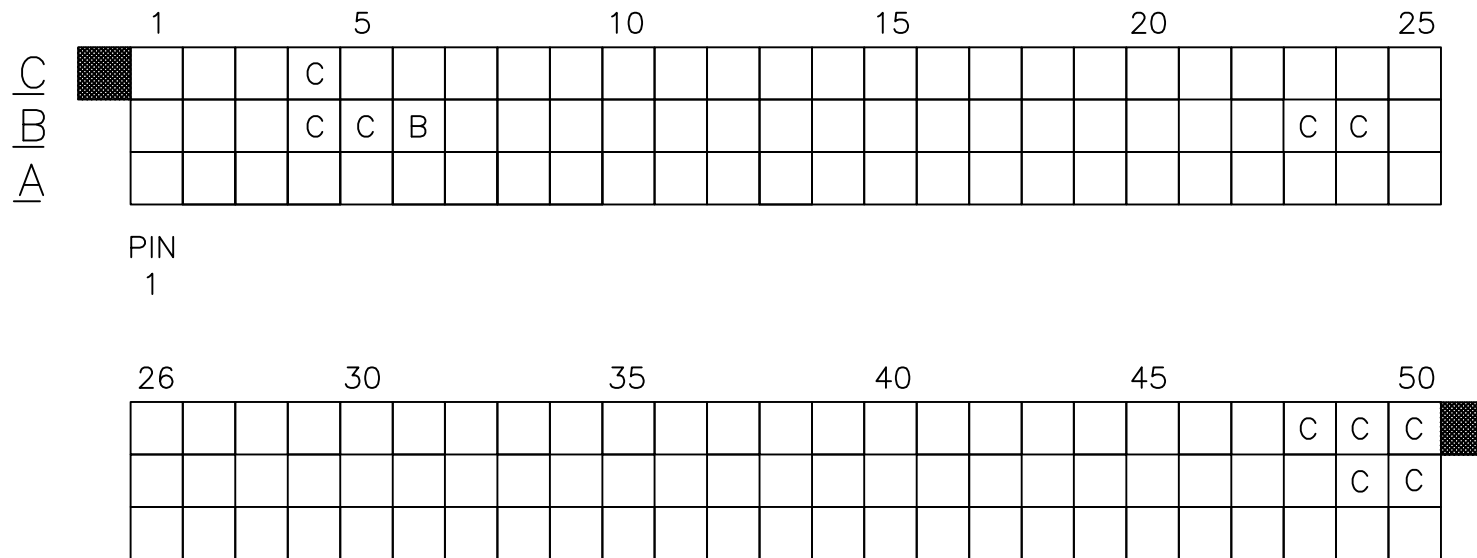

CUSTOMER NOTE: END GUIDE PINS ARE SUGGESTED IN YOUR APPLICATION TO PREVENT STUBBING OF THE .260 MATING LENGTH SIGNAL PINS.

- ALL POSITIONS ARE LOADED WITH "A" EXCEPT AS SHOWN.
- COLUMN 1, ROW A IS DESIGNATED AS SIGNAL PIN 1, AS VIEWED FROM THE MATING FACE.
- SIGNAL DATA FOR 50006-XX053 AND 50006-XX053LF:
 SIZE 3 x 50
 TOTAL NO. OF POSITIONS - 150
 NO. OF POSITIONS LOADED - 150

ITEM KEY	QTY.	MATING LENGTH	TAIL LENGTH
A	139	.220 / 5.59	.250 / 6.35
B	1	.180 / 4.57	.250 / 6.35
C	10	.260 / 6.60	.250 / 6.35

mat'l. code		surface ISO 1302 ✓		tolerance ISO 406 ISO 1101		projection 		product family HPC	
ltr	ecn no	dr	date	tolerances unless otherwise specified		INCH/MM		title 3 ROW VERTICAL HEADER W/PRESS-FIT PINS, 0 G.P.	
P				angles	linear	scale 1:1		dwg no 50006	
				0°±2'	.XX±.01/.3 .XXX±.005/.13 .XXXX±.0020/.051	Amphenol FCi		sheet 10 of 17 size A3	
				dr	D.SHEAFER 1991-03-14			type Product Customer Drawing	
				enr	S.CLARK 1991-03-14				
				chr	S ALOSIOUS 2011-05-23				
				appd	BIJU K PAUL 2011-05-23				
sheet index	revision sheet								

PRODUCT NUMBER
50006-XX054
50006-XX054LF

FOR PRODUCT NUMBERS 50006-XX054 AND 50006-XX054LF ONLY

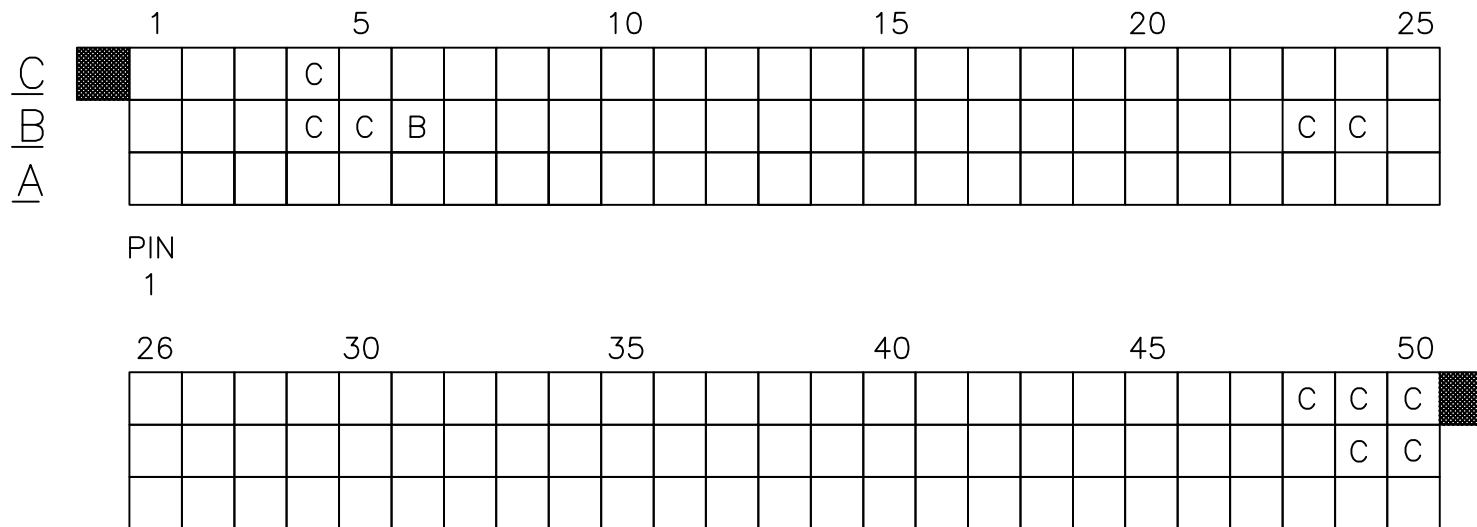

CUSTOMER NOTE: END GUIDE PINS ARE SUGGESTED IN YOUR APPLICATION TO PREVENT STUBBING OF THE .260 MATING LENGTH SIGNAL PINS.

NOTES FOR 50006-XX054 AND 50006-XX054LF ONLY:

1. ALL POSITIONS ARE LOADED WITH "A" EXCEPT AS SHOWN.
2. COLUMN 1, ROW A IS DESIGNATED AS SIGNAL PIN 1, AS VIEWED FROM THE MATING FACE.
3. SIGNAL DATA FOR 50006-XX054 AND 50006-XX054LF:
 SIZE 3 x 50
 TOTAL NO. OF POSITIONS - 150
 NO. OF POSITIONS LOADED - 150

ITEM KEY	QTY.	MATING LENGTH	TAIL LENGTH
A	139	.220 / 5.59	.561 / 14.25
B	1	.180 / 4.57	.521 / 13.23
C	10	.260 / 6.60	.601 / 15.27

mat'l. code		surface ISO 1302 <input checked="" type="checkbox"/>		tolerance ISO 406 ISO 1101		projection 		product family HPC	
ltr	ecn no	dr	date	tolerances unless otherwise specified		INCH/MM		title	
P				angles	linear	.XX±.01/.3		3 ROW VERTICAL HEADER	
				0°±2'		.XXX±.005/.13		W/PRESS-FIT PINS, 0 G.P.	
						.XXX±.0020/.051		scale 1:1	
		dr	D.SHEAFER	1991-03-14	Amphenol FCi		dwg no		sheet 11 of 17
		enr	S.CLARK	1991-03-14			50006		A3
		chr	S ALOSIUS	2011-05-23					
		appd	BIJU K PAUL	2011-05-23			type		Product Customer Drawing
sheet index	revision sheet								

PRODUCT NUMBER
50006-XX055
50006-XX055LF

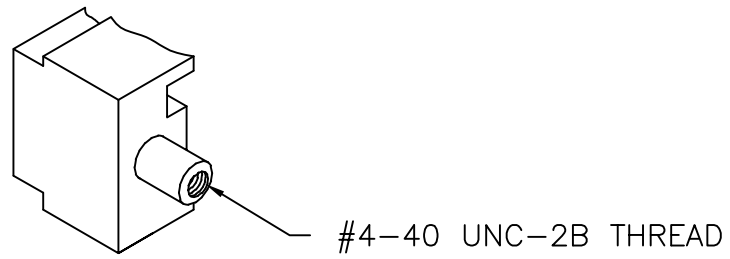

L.E.

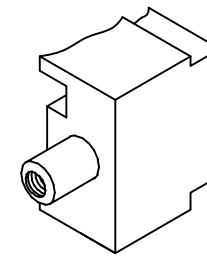

R.E.

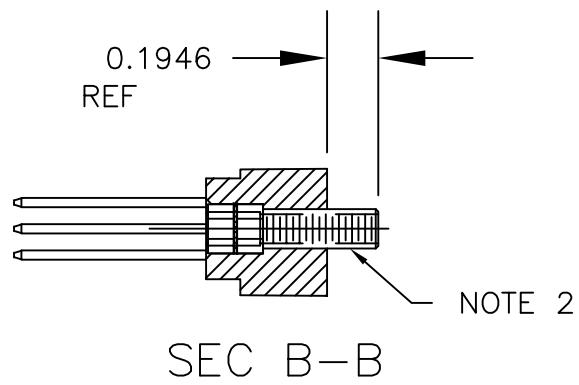

SEC B-B

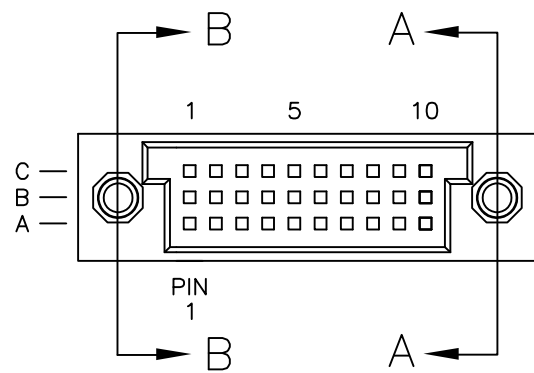

C
B
A

PIN 1

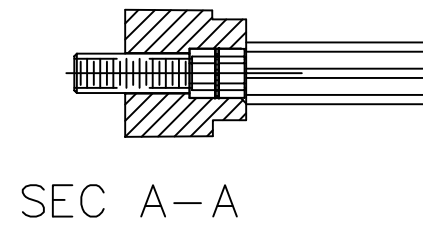

SEC A-A

FOR PRODUCT NUMBERS 50006-XX055 AND 50006-XX055LF

NOTES:

1. IDENTICAL TO P/N 50006-1030D EXCEPT AS SHOWN W/JACK SCREW INSERTS INSTALLED ON BOTH ENDS.
2. HARDWARE P/N 95729-001.

mat'l. code		surface ISO 1302 ✓		tolerance ISO 406 ISO 1101		projection INCH/MM		product family HPC		
ltr	ecn no	dr	date	tolerances unless otherwise specified		INCH/MM		title 3 ROW VERTICAL HEADER W/PRESS-FIT PINS, 0 G.P.		
P				angles	linear	scale 1:1		dwg no 50006		
				0°±2'	.XX±.01/.3 .XXX±.005/.13 .XXXX±.0020/.051			sheet 12 of 17 size A3		
				dr	D.SHEAFER	1991-03-14	Amphenol FCi		type Product Customer Drawing	
				enr	S.CLARK	1991-03-14				
				chr	S ALOSIUS	2011-05-23				
				appd	BIJU K PAUL	2011-05-23				
sheet index	revision sheet									

PRODUCT NUMBER
50006-XX056
50006-XX056LF

FOR PRODUCT NUMBER 50006-XX056 AND 50006-XX056LF ONLY

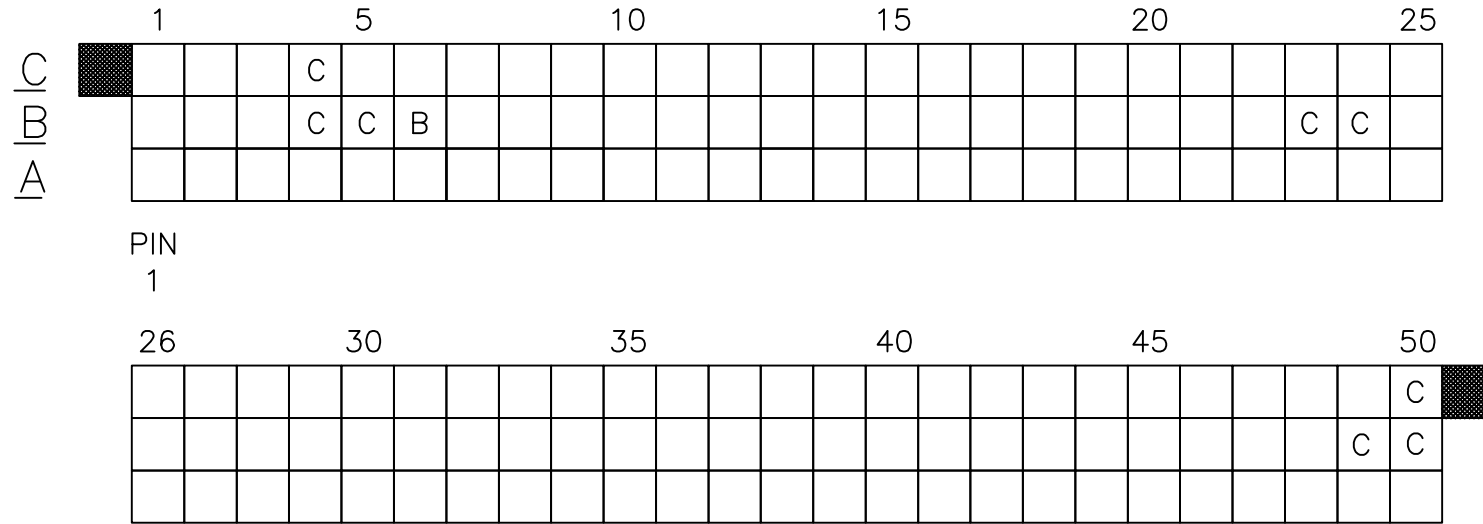

CUSTOMER NOTE: END GUIDE PINS ARE SUGGESTED IN YOUR APPLICATION TO PREVENT STUBBING OF THE .260 MATING LENGTH SIGNAL PINS.

NOTES FOR 50006-XX056 AND 50006-XX056LF ONLY:

1. ALL POSITIONS ARE LOADED WITH "A" EXCEPT AS SHOWN.
2. COLUMN 1, ROW A IS DESIGNATED AS SIGNAL PIN 1, AS VIEWED FROM THE MATING FACE.
3. SIGNAL DATA FOR 50006-XX056 AND 50006-XX056LF:
 SIZE 3 x 50
 TOTAL NO. OF POSITIONS - 150
 NO. OF POSITIONS LOADED - 150

ITEM KEY	QTY.	MATING LENGTH	TAIL LENGTH
A	141	.220 / 5.59	.177 / 4.50
B	1	.180 / 4.57	.177 / 4.50
C	8	.260 / 6.60	.177 / 4.50

mat'l. code		surface ISO 1302 ✓		tolerance ISO 406 ISO 1101		projection 		product family HPC	
ltr	ecn no	dr	date	tolerances unless otherwise specified		INCH/MM		title	
P				angles	linear	scale 1:1		3 ROW VERTICAL HEADER W/PRESS-FIT PINS, 0 G.P.	
				0°±2'	.XX±.01/.3 .XXX±.005/.13 .XXXX±.0020/.051			dwg no	
				dr	D.SHEAFER	1991-03-14	Amphenol FCi		sheet 13 of 17
				enr	S.CLARK	1991-03-14	50006		size A3
				chr	S ALOSIOUS	2011-05-23	Product Customer Drawing		
				appd	BIJU K PAUL	2011-05-23			
sheet index	revision sheet								

PRODUCT NUMBER
50006-XX057
50006-XX057LF

FOR PRODUCT NUMBER 50006-XX057 AND 50006-XX057LF

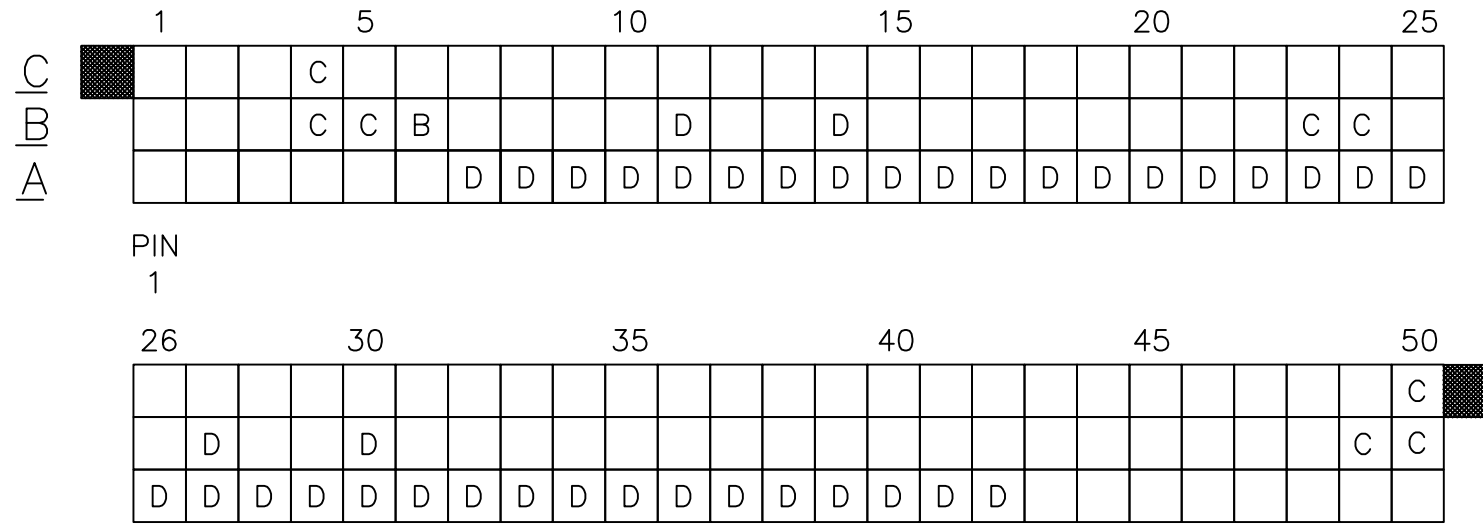

CUSTOMER NOTE: END GUIDE PINS ARE SUGGESTED IN YOUR APPLICATION TO PREVENT STUBBING OF THE .260 MATING LENGTH SIGNAL PINS.

NOTES FOR 50006-XX057 AND 50006-XX057LF ONLY:

1. ALL POSITIONS ARE LOADED WITH "A" EXCEPT AS SHOWN.
2. COLUMN 1, ROW A IS DESIGNATED AS SIGNAL PIN 1, AS VIEWED FROM THE MATING FACE.
3. SIGNAL DATA FOR 50006-XX057 AND 50006-XX057LF:
 SIZE 3 x 50
 TOTAL NO. OF POSITIONS - 150
 NO. OF POSITIONS LOADED - 150

ITEM KEY	QTY.	MATING LENGTH	TAIL LENGTH
A	101	.220 / 5.59	.561 / 14.25
B	1	.180 / 4.57	.521 / 13.23
C	8	.260 / 6.60	.601 / 15.27
D	40	.220 / 5.59	.177 / 4.50

mat'l. code		surface ISO 1302 ✓		tolerance ISO 406 ISO 1101		projection 		product family HPC	
ltr	ecn no	dr	date	tolerances unless otherwise specified		INCH/MM		title	
P				angles	linear	scale 1:1		3 ROW VERTICAL HEADER W/PRESS-FIT PINS, 0 G.P.	
				0°±2'	.xxx±.005/.13			dwg no	
				dr	D.SHEAFER	1991-03-14	Amphenol FCi		sheet 14 of 17
				enr	S.CLARK	1991-03-14	50006		A3
				chr	S ALOSIUS	2011-05-23	type		Product Customer Drawing
				appd	BIJU K PAUL	2011-05-23			
sheet index	revision sheet								

PRODUCT NUMBER
50006-XX058
50006-XX058LF

FOR PRODUCT NUMBER 50006-XX058 AND 50006-XX058LF

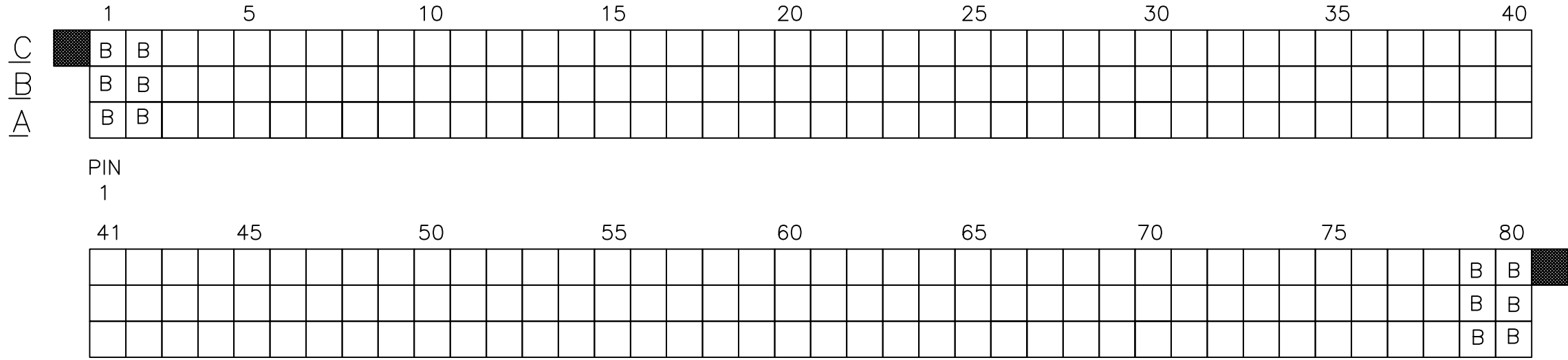

CUSTOMER NOTE: END GUIDE PINS ARE SUGGESTED IN YOUR APPLICATION TO PREVENT STUBBING OF THE .260 MATING LENGTH SIGNAL PINS.

NOTES FOR 50006-XX058 AND 50006-XX058LF ONLY:

- ALL POSITIONS ARE LOADED WITH "A" EXCEPT AS SHOWN.
- COLUMN 1, ROW A IS DESIGNATED AS SIGNAL PIN 1, AS VIEWED FROM THE MATING FACE.
- SIGNAL DATA FOR 50006-XX058 AND 50006-XX058LF:
 SIZE 3 x 80
 TOTAL NO. OF POSITIONS - 240
 NO. OF POSITIONS LOADED - 240

ITEM KEY	QTY.	MATING LENGTH	TAIL LENGTH
A	228	.210 / 5.33	.533 / 13.54
B	12	.244 / 6.20	.533 / 13.54

mat'l. code		surface ISO 1302 ✓		tolerance ISO 406 ISO 1101		projection 		product family HPC	
ltr	ecn no	dr	date	tolerances unless otherwise specified		INCH/MM		title 3 ROW VERTICAL HEADER W/PRESS-FIT PINS, 0 G.P.	
P				angles	linear	scale 1:1		dwg no 50006	
				0°±2'	.XX±.01/.3 .XXX±.005/.13 .XXXX±.0020/.051			sheet 15 of 17 size A3	
				dr	D.SHEAFER 1991-03-14	Amphenol FCi		type Product Customer Drawing	
				enr	S.CLARK 1991-03-14				
				chr	S ALOSIUS 2011-05-23				
				appd	BIJU K PAUL 2011-05-23				
sheet index	revision sheet								

PRODUCT NUMBER
50006-XX059
50006-XX059LF

FOR PRODUCT NUMBER 50006-XX059 AND 50006-XX059LF

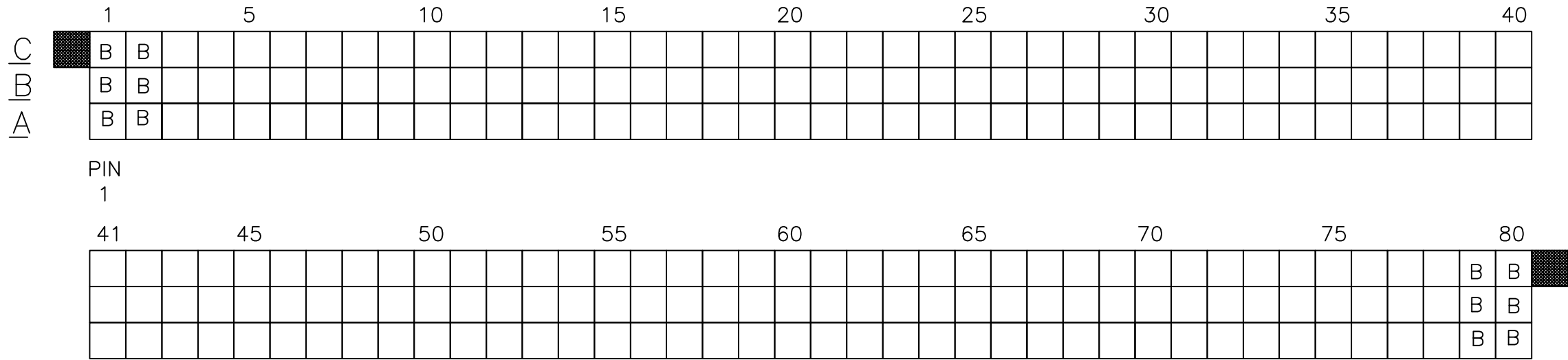

CUSTOMER NOTE: END GUIDE PINS ARE SUGGESTED IN YOUR APPLICATION TO PREVENT STUBBING OF THE .260 MATING LENGTH SIGNAL PINS.

NOTES FOR 50006-XX059 AND 50006-XX059LF ONLY:

- ALL POSITIONS ARE LOADED WITH "A" EXCEPT AS SHOWN.
- COLUMN 1, ROW A IS DESIGNATED AS SIGNAL PIN 1, AS VIEWED FROM THE MATING FACE.
- SIGNAL DATA FOR 50006-XX059 AND 50006-XX059LF:
 SIZE 3 x 80
 TOTAL NO. OF POSITIONS - 240
 NO. OF POSITIONS LOADED - 240

ITEM KEY	QTY.	MATING LENGTH	TAIL LENGTH
A	228	.210 / 5.33	.660 / 16.76
B	12	.245 / 6.22	.660 / 16.76

mat'l. code		surface ISO 1302 ✓		tolerance ISO 406 ISO 1101		projection 		product family HPC	
ltr	ecn no	dr	date	tolerances unless otherwise specified		INCH/MM		title	
P				angles	linear	scale 1:1		3 ROW VERTICAL HEADER W/PRESS-FIT PINS, 0 G.P.	
				0°±2'	.XX±.01/.3 .XXX±.005/.13 .XXXX±.0020/.051			dwg no	
				dr	D.SHEAFER	1991-03-14	Amphenol FCi		sheet 16 of 17
				enr	S.CLARK	1991-03-14	50006		size A3
				chr	S ALOSIUS	2011-05-23	Product Customer Drawing		
				appd	BIJU K PAUL	2011-05-23			
sheet index	revision sheet								

PRODUCT NUMBER
50006-XX060LF

FOR PRODUCT NUMBER 50006-XX060LF ONLY

	1	5	10	15	20	25	30
C	A	A	A	A	A	A	A
B	A	A	A	A	A	A	A
A	A	A	A	A	A	A	A

PIN
1

	31	35	40	45	50	55
A	A	A	A	A	A	A
			A	A	A	A
A	A	A	A	A	A	A

NOTES : FOR 50006-XX060LF ONLY:

- ALL POSITIONS ARE LOADED, EXCEPT OMITTS, AS SHOWN.
- COLUMN 1, ROW A IS DESIGNATED AS SIGNAL PIN 1, AS VIEWED FROM THE MATING FACE.
- SIGNAL DATA FOR 50006-XX060LF:
SIZE 3 x 55
TOTAL NO. OF POSITIONS - 165
NO. OF POSITIONS LOADED - 107

ITEM KEY	QTY.	MATING LENGTH	TAIL LENGTH
A	107	.220 / 5.59	.250 / 6.35
BLANK	58	N/A	N/A

mat'l. code		surface ISO 1302 ✓	tolerance ISO 406 ISO 1101	projection 	product family HPC
ltr	ecn no	dr	date	tolerances unless otherwise specified	title 3 ROW VERTICAL HEADER W/PRESS-FIT PINS, 0 G.P.
B				linear .XX±.01/.3 .XXX±.005/.13 .XXXX±.0020/.051	
				angles 0°±2'	INCH/MM scale 1:1
		dr	M JACOB	2019-01-03	dwg no
		enr	M JACOB	2019-01-03	sheet 17 of 17
		chr	M JACOB	2019-01-04	size 50006 A3
		appd	BIJU K PAUL	2019-01-04	type Product Customer Drawing
sheet index	revision sheet				