

REVISIONS					
P.	LTN	DESCRIPTION	DATE	DWN	APVD
D1		REVISED PER ECO-12-003443	24FEB2012	DD	RL
D2		REVISED PER ECO-13-019739	06JAN2014	DD	RL
D3		REVISED PER ECO-14-014459	09OCT2014	DD	RL

- 1. CIRCUIT IDENTIFICATION NUMBERS LOCATED AS SHOWN.
- 2. SPACER AND CPA ARE SHIPPED IN PRE-ASSEMBLED POSITION.
- 3. PART NUMBER AND DATE CODE.
- 4. CAVITY ID.
- 5. MATERIAL SPECIFICATION.
- 6. PACKING: CONNECTOR ASSEMBLIES BULK PACKED IN CARDBOARD BOX.

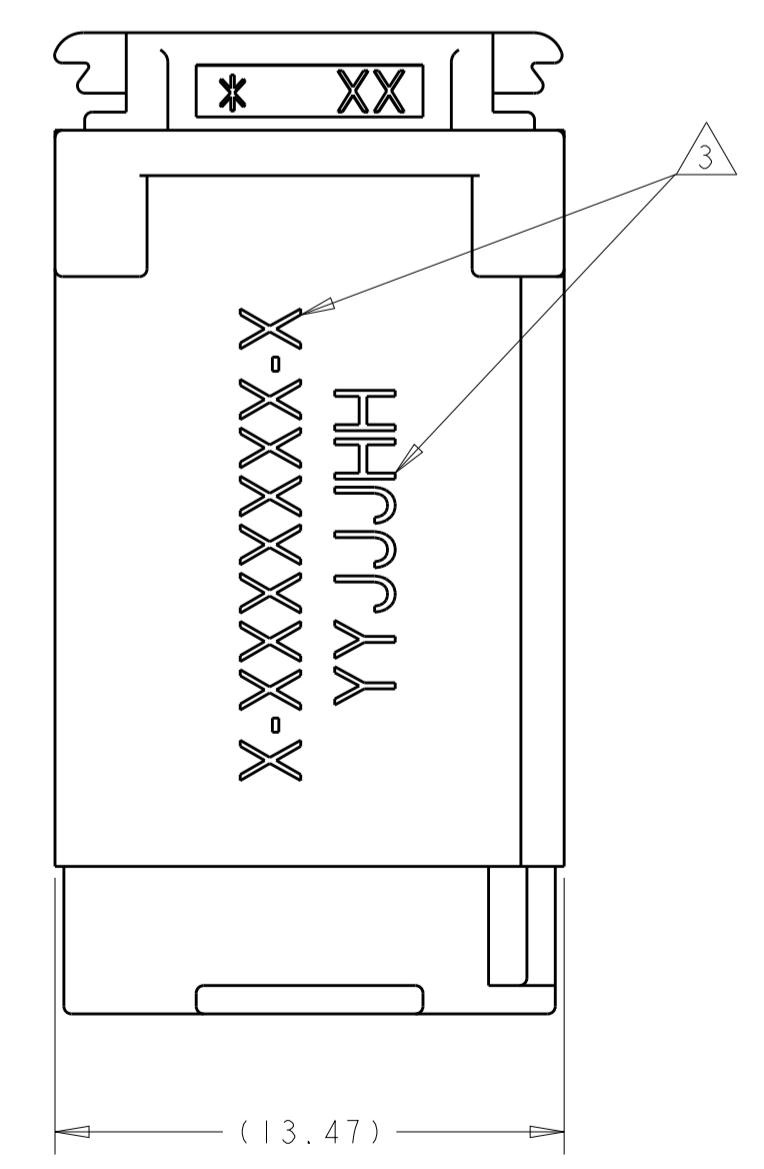
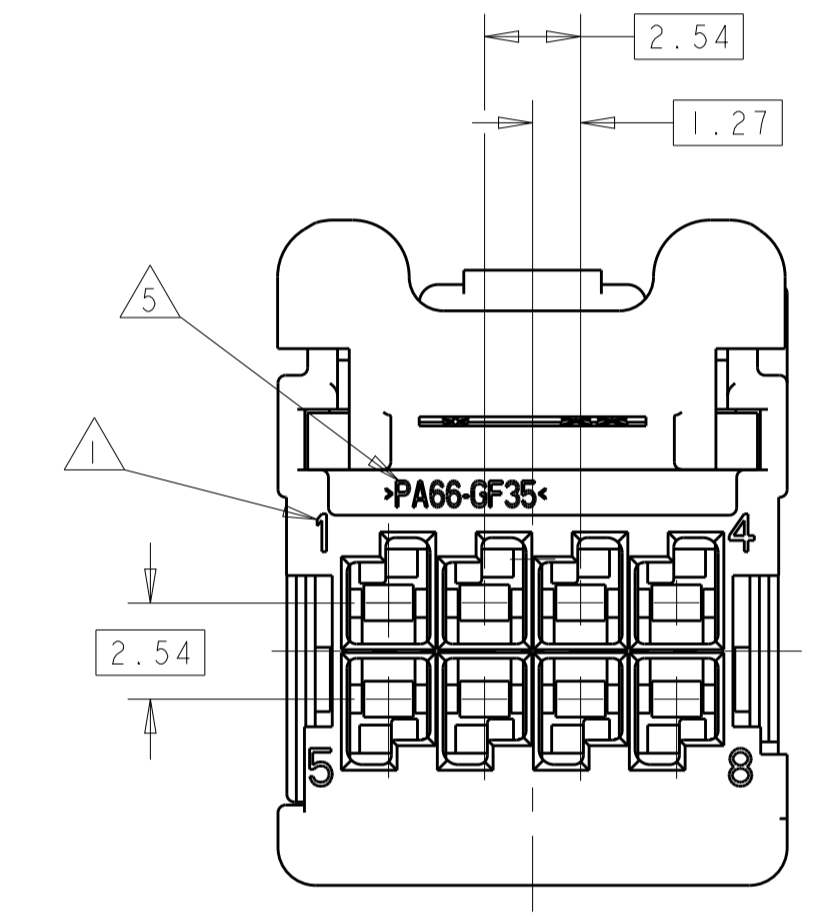
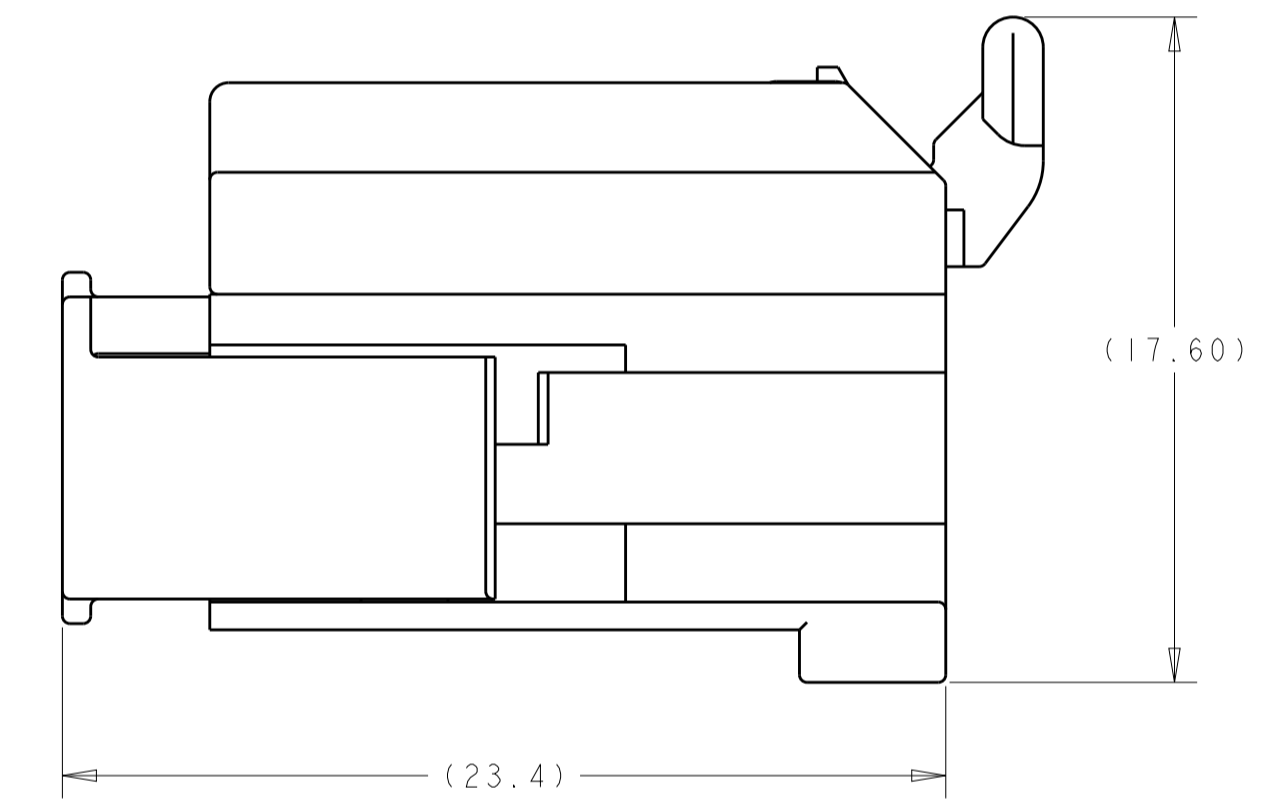
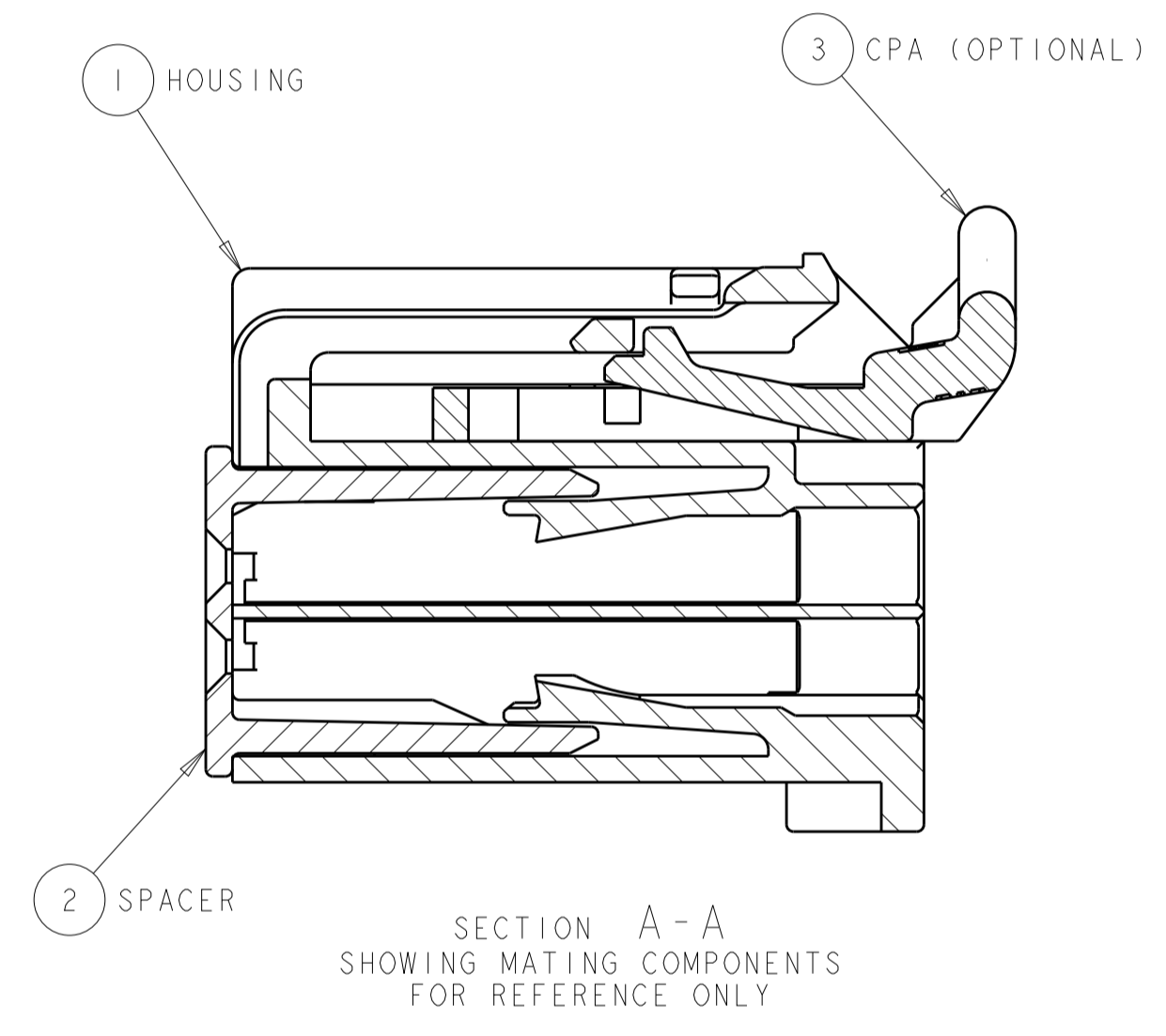
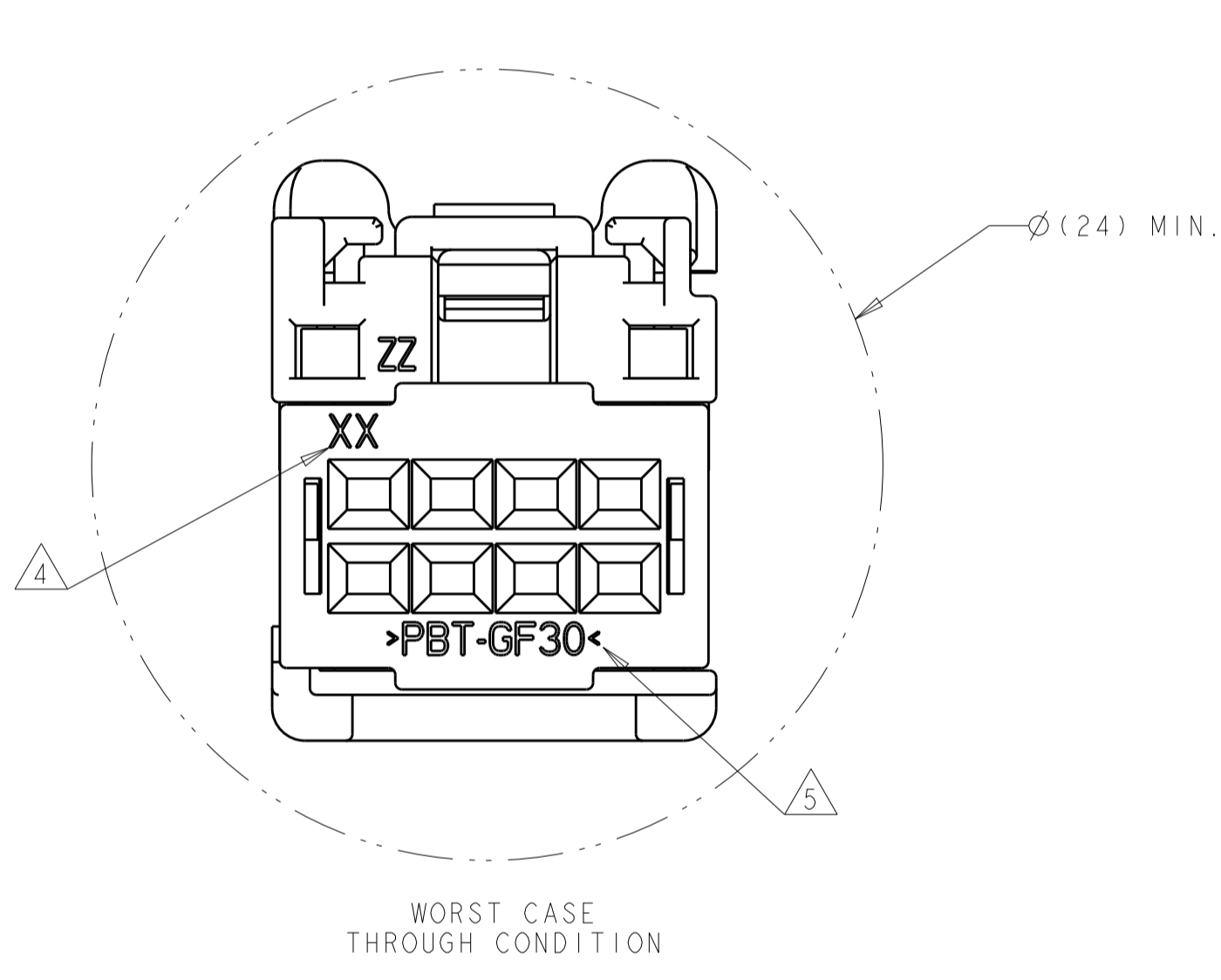
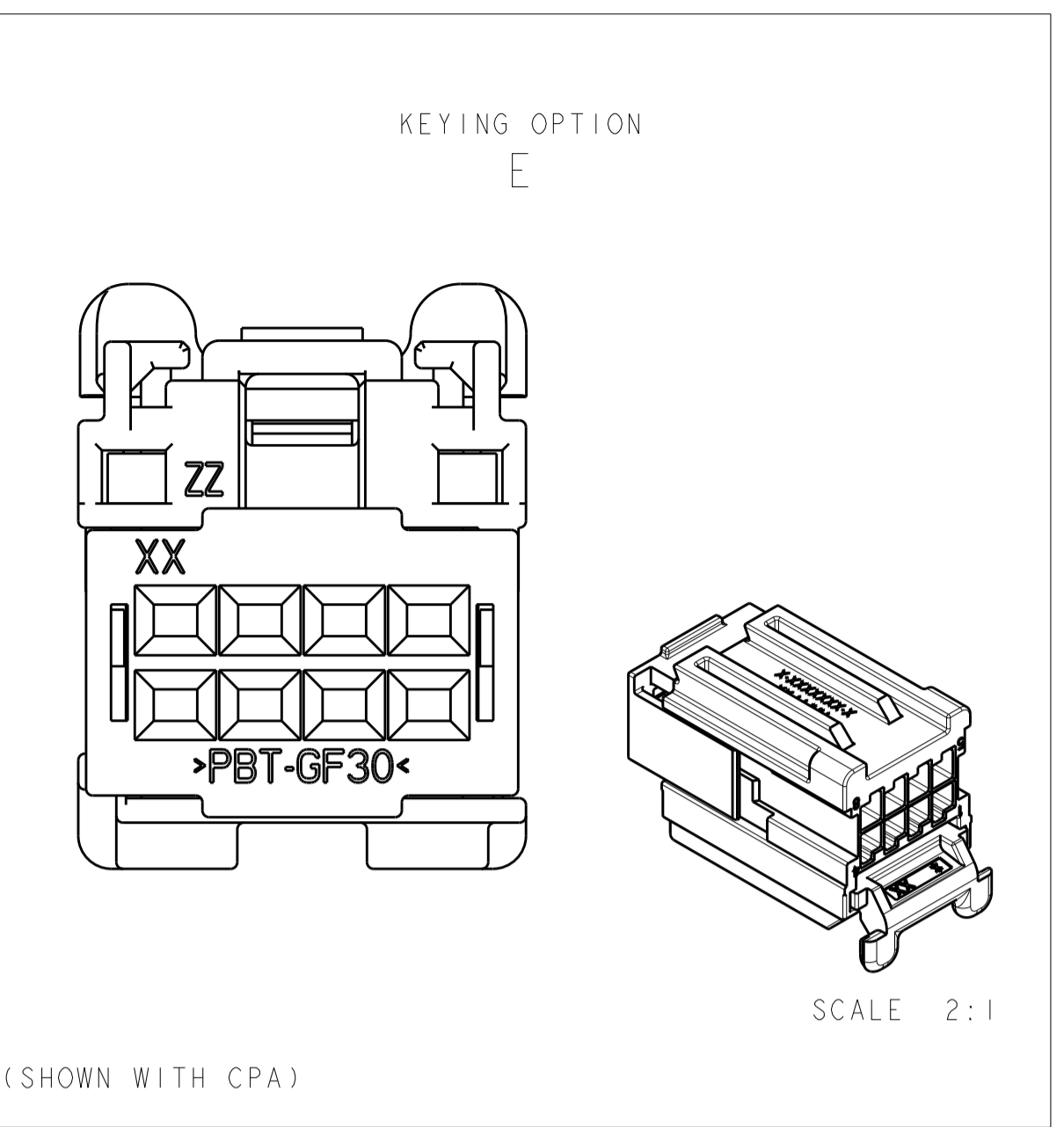
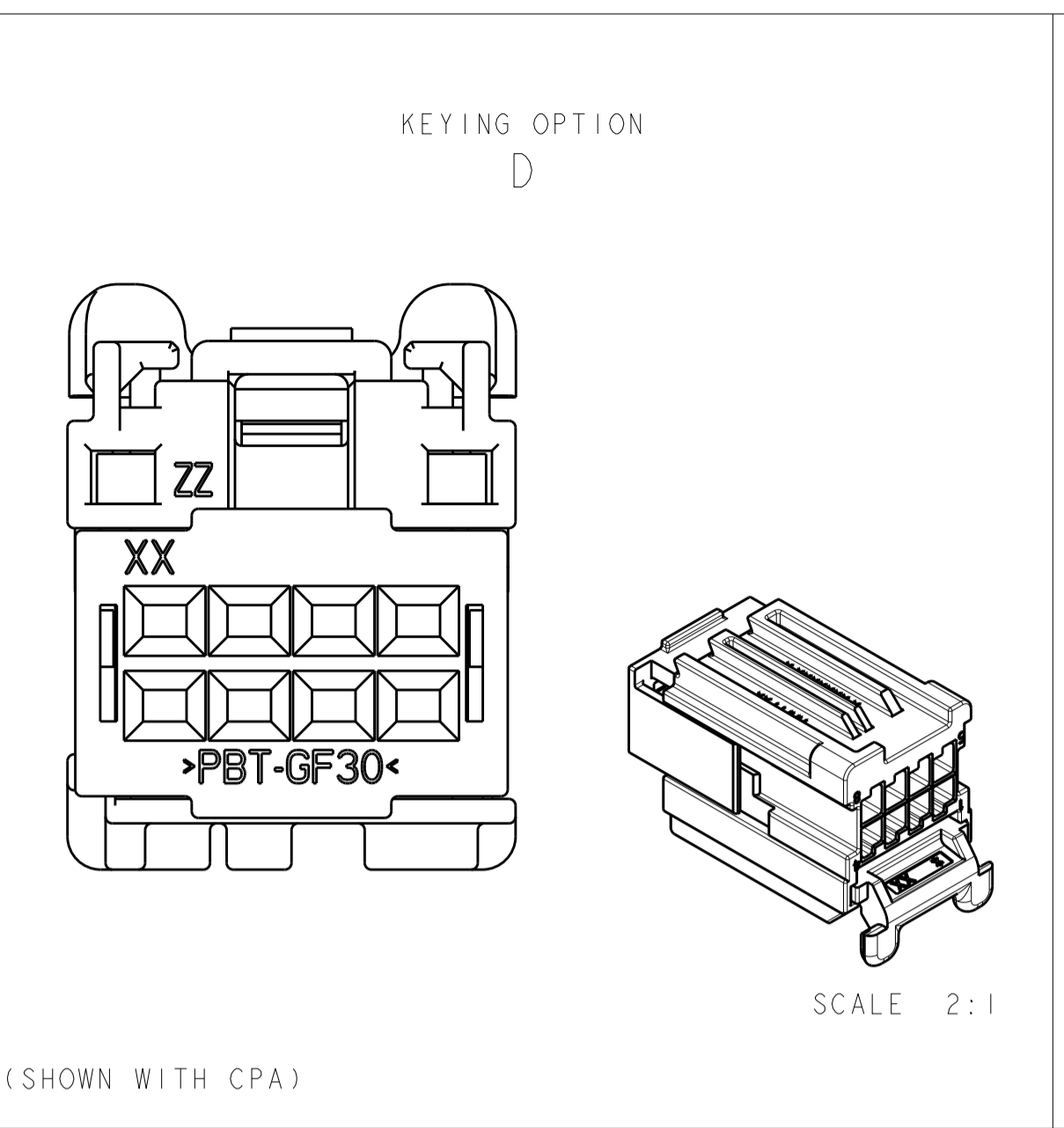
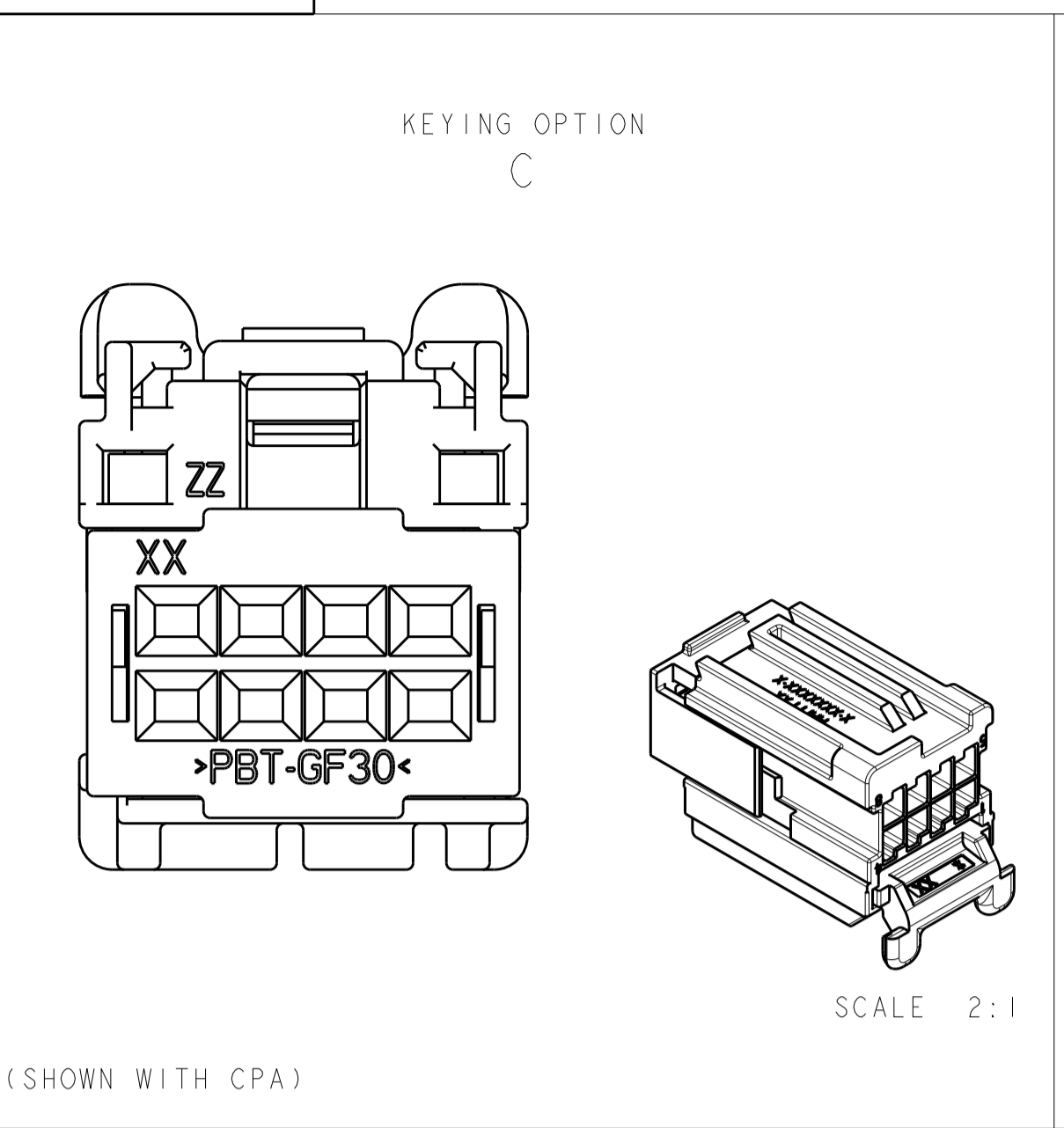
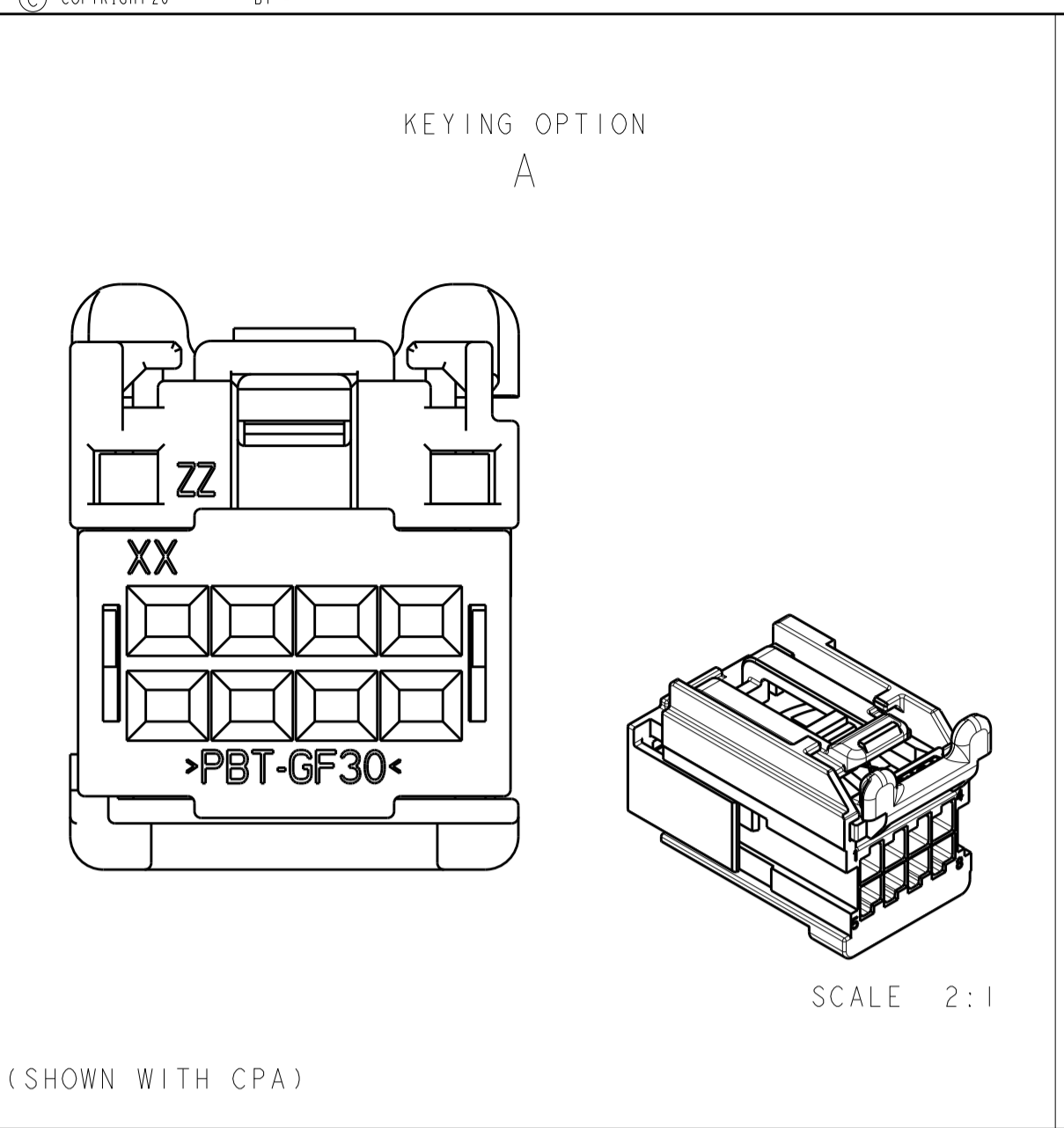

ITEM NO	DESCRIPTION	MATERIAL	COLOR	QTY REQ'D PER ASSY	REVISION OF EACH ASSY NO (WHEN BLANK, USE DWG REVISION)	WEIGHT OF EACH ASSY NO (g)
1	CPA	>PBT-GF20<	RED	3		
2	SPACER	>PBT-GF30<	RED	2		
1	HOUSING; KEY E	>PA66-GF35<	BLACK	1		
1	HOUSING; KEY D	>PA66-GF35<	BLACK	1		
1	HOUSING; KEY C	>PA66-GF35<	BLACK	1		
1	HOUSING; KEY A	>PA66-GF35<	BLACK	1		
	ASSEMBLY PN					

PARTS LIST

THIS DRAWING IS A CONTROLLED DOCUMENT.

DWN: R. VESTAL 14DEC2006  
CHK: D. STRAUSSER 14DEC2006  
APVD: D. STRAUSSER 14DEC2006

NAME: 2X4 POSITION, GET, FEMALE CONNECTOR, ASSEMBLY

SIZE: A1  
CAGE CODE: 100779  
DRAWING NO: 1456987

RESTRICTED TO: REV D3

SCALE: 5:1 SHEET 1 OF 1

STE TE Connectivity