

THIS IS A C.A.D. GENERATED DRAWING
DO NOT MAKE MANUAL REVISIONS TO MASTER.

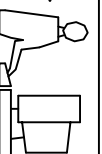

ISSUE NUMBER
ORIGINAL
①

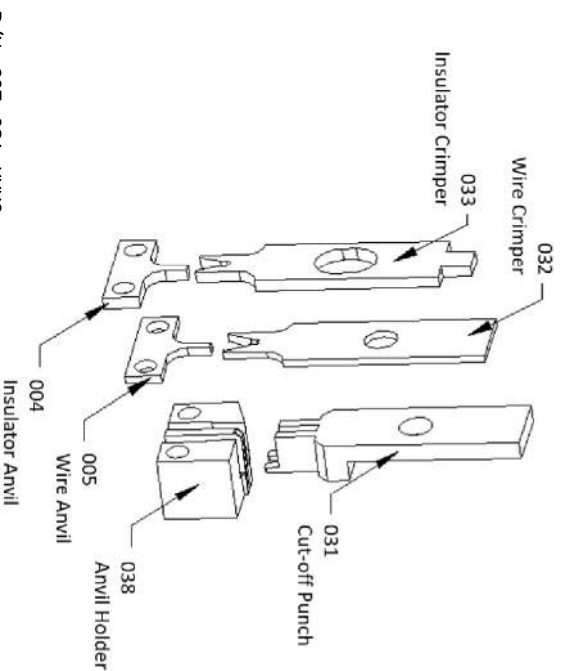
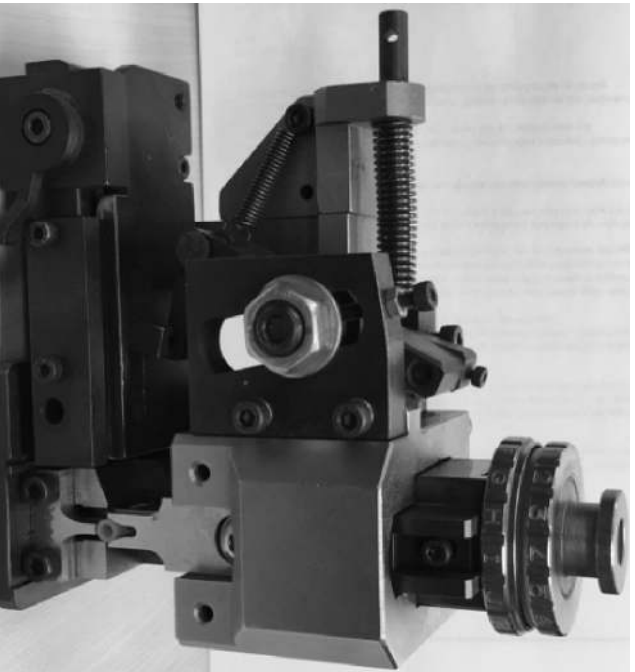

P/N: 627-281-XXXX

PRESS TYPE	G PRESS
STROKE LENGTH	40.00 MM
SHUT HEIGHT	135.79 MM
AWG	20-28

REPLACEMENT PUNCH & DIE PARTS					
INSULATOR ANVIL	WIRE ANVIL	WIRE CRIMPER	INSULATOR CRIMPER	CUT OFF PUNCH	ANVIL HOLDER
627-281-004G	627-281-005G	627-281-032G	627-281-033G	627-281-031G	627-281-038G

NOTES:

- 1- THIS APPLICATOR IS DESIGNED TO BE USED ON A G CRIMPING MACHINE.
- 2- THIS APPLICATOR IS DESIGNED FOR CRIMPING EDAC CONTACT P/N 627-290-001.
- 3- FOR THE DEFINITION OF STROKE LENGTH AND SHUT HEIGHT, APPLICATOR SETUP AND OPERATING INSTRUCTION, PLEASE REFER TO DOCUMENT "APPLICATOR INSTRUCTION MANUAL G PRESS".

G PRESS APPLICATOR FOR 627-290-001

EDAC INC
TORONTO, ONTARIO
CANADA

THESE DRAWINGS AND SPECIFICATIONS ARE THE PROPERTY OF EDAC INC. AND SHALL NOT BE REPRODUCED, OR COPIED OR USED AS THE BASIS FOR THE MANUFACTURE OR SALE OF APPARATUS WITHOUT WRITTEN PERMISSION.

ACAD REFERENCE NO.	627-280-751G	
DRAWN:	K.L.	DATE: OCT.29/2020
CHECKED:	R.S.M.	DATE: OCT.29/2020
SCALE:	N.T.S.	SHEET 1 OF 1
DRAWING NUMBER	627-280-751G	
ISSUE	1	