

DESCRIPTION

The LX2207 can use a wall adapter or USB power source to charge a single cell Lithium Ion or Lithium Polymer battery. There are three logic selectable and programmable charge current levels: the high charge programming level is typically set for charging from the adapter, the low level charge programming level is typically set to 500mA for USB full USB charging and 100mA (20%) for reduced level USB charging.

In addition to setting the high-level charge current, the HCP programming resistor also sets the termination current at 10% of the constant current level and the conditioning mode is provided for deeply discharged batteries. Power status indicators (STAT and DCOK) can be configured to show

charge in progress, battery fully charged and external power on. The STAT pin is capable of sourcing or sinking 10mA. The DCOK output is an open drain output and can sink 20mA.

The LX2207 enters a low quiescent current sleep mode when power is removed or when it is logically shutdown to minimize battery drain.

There are several protection features which include: under voltage lock out, reverse current blocking on the IN pin, a thermal loop to reduce charge current to maintain a low die temperature, an unsafe battery temperature charge inhibitor, and conditioning mode is provided for deeply discharged batteries.

KEY FEATURES

- Three charge levels for adapter, and USB Hi and Low
- 0.5% Float voltage tolerance
- Charging up to 1A.
- Charging from USB port.
- USB current compliance
- Full battery Indicator
- CC/CV w thermal Feedback
- Battery temp monitor
- Precision charge termination
- Power Good Indication

APPLICATIONS

- MP3 player
- PDA
- PMC
- Digital Camera
- Charge Cradle

IMPORTANT: For the most current data, consult MICROSEMI's website: <http://www.microsemi.com>

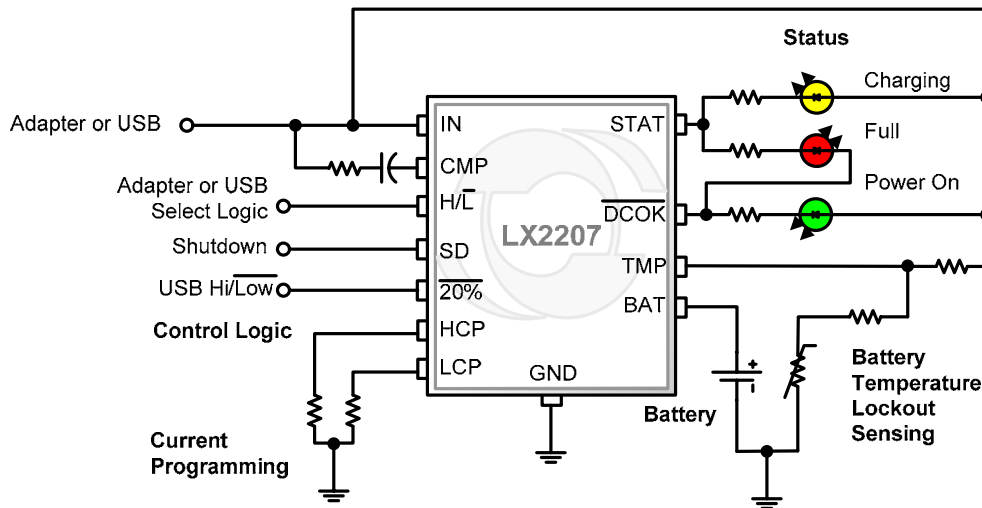
PRODUCT HIGHLIGHT

PACKAGE ORDER INFO

T_A (°C)	LD	Plastic MLPD
		12-Pin
		RoHS Compliant / Pb-free
-40 to 85	LX2207ILD	

Note: Available in Tape & Reel. Append the letters "TR" to the part number. (i.e. LX2207ILD-TR)

ABSOLUTE MAXIMUM RATINGS

Supply Input Voltage (IN, BAT)	-0.3V to 7V
All other pins	-0.3V to V _{SUPPLY}
Battery Charging Current	1.1A
Operating Temperature Range	-40 to 150°C
Maximum Operating Junction Temperature	150°C
Storage Temperature Range	-65°C to 150°C
Peak Temp. for Solder Reflow (40 seconds maximum exposure).....	260°C (+0 -5)

Note: Exceeding these ratings could cause damage to the device. All voltages are with respect to Ground. Currents are positive into, negative out of specified terminal.

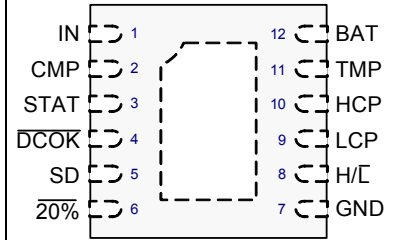
PACKAGE PIN OUT

LD Package
(Top View)

RoHS / Pb-free 100% matte Tin Finish

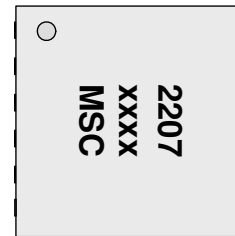

Part Marking
xxxx = Denotes date and lot code Identification

THERMAL DATA
LD Plastic Micro Leadframe Package 12-Pin

THERMAL RESISTANCE-JUNCTION TO AMBIENT, θ_{JA}	33°C/W
---	---------------

Junction Temperature Calculation: $T_J = T_A + (P_D \times \theta_{JA})$.

The θ_{JA} numbers are guidelines for the thermal performance of the device/pc-board system. All of the above assume no ambient airflow.

FUNCTIONAL PIN DESCRIPTION

Name	Pin #	Description
BAT	12	Battery – Connect to a single cell Lithium Ion Battery.
CMP	2	Compensation – Connect a series combination of a 1k resistor and a 0.47 μ F capacitor from CMP to IN.
$\overline{\text{DCOK}}$	4	Power status logic pin and LED driver – This pin is an open drain output that can sink 20mA of current to drive an external LED. This pin is low impedance to GND when the Input voltage is high enough to charge the Battery.
GND	7	Ground – Connect to the system ground.
HCP	10	High Current Programming (and Termination Current Programming) – Connect a resistor to ground to set the constant current high level. The termination current is set to 1/10 of the High Current Programming Level. For a value of 19.6k, the High Current is 460mA and the Termination Current is 46mA.
H/L	8	High or Low load select logic input – A logic high selects the constant charge current level set by the HCP pin resistor and a logic low selects the constant charge current level set by the LCP pin resistor
IN	1	Input Power – Connect to a wall adapter or a USB power plug.
LCP	9	Low Current Programming – Connect a resistor to ground to set the constant current low level. For a value of 19.6k, the High Current is 460mA and the 20% current is 92mA.
SD	5	Shutdown – A logic high places the LX2207 in sleep mode; can also be used for USB suspend.
STAT	3	Charging status logic pin and LED driver – This pin can source or sink 10mA of current to drive an external LED in either output state. This pin is low (current sinking mode) when the battery is in charging mode and becomes high (current sourcing mode) when the charge cycle is finished. It becomes high impedance when the input power is removed.
TMP	11	Battery Temperature Monitor – This sense pin determines the battery temperature for charging out of temperature range lockout and is connected to a resistor network as defined in the Applications section. The TMP pin is grounded if this function is not used.
$\overline{20\%}$	6	20% select logic input – When the low current level is selected by the H/L pin, a logic high on $\overline{20\%}$ selects the constant charge current level set by the LCP pin resistor and a logic low selects 20% of this value.



ELECTRICAL CHARACTERISTICS

The following specifications apply over the operating ambient temperature $-40^{\circ}\text{C} \leq T_A \leq 85^{\circ}\text{C}$ except where otherwise noted and the following test conditions: $I_N = 5.0\text{V}$; SD = Low; H/L = High, 20% = High; BAT = 3.6V; HCP=12.1k, LCP=19.6k; TMP = 0V.

Parameter	Symbol	Test Conditions	LX2207			Units
			Min	Typ	Max	
INPUT CIRCUITRY						
Input Voltage	V_{IN}		4.35		6	V
Battery Voltage	V_{BAT}				4.3	V
Under Voltage Charging Lockout	$V_{IN\ UVLO}$	Rising input $V_{BAT} = 3.2\text{V}$	3.5	3.8	4	V
UVLO Hysteresis				300		mV
Input Supply Current	I_{IN}	$V_{BAT} = 4.2\text{V}$; battery charged		1	2	mA
		SHDN = High		35	50	μA
BATTERY CHARGER						
Constant Voltage Charging	V_{BAT}	$I_{BAT} < 100\text{mA}$	4.16	4.2	4.24	V
Constant Voltage Charging	V_{BAT}	$I_{BAT} < 100\text{mA} @ 25\text{C}$	4.18	4.2	4.22	V
HCP Bias Voltage	V_{HCP}	$I_{BAT} > 100\text{mA}$		1.25		V
LCP Bias Voltage	V_{LCP}			1.25		V
Max Battery Charge Current	I_{BAT}	HCP=12.1k	665	710	772	mA
		H/L = Low	430	460	495	mA
		H/L = Low, 20% = Low	84	92	97	mA
Conditioning Current	I_{BAT}	$V_{BAT} < VCCT$	13	23	33	mA
Conditioning Current	I_{COND}	$V_{BAT} < VCCT$; HCP = 110k	2.6	4.6	7.8	mA
Conditioning Current Threshold	V_{BAT}	Rising Battery Voltage	2.5	2.7	2.9	V
Charge Termination Current	I_{BAT}	HCP = 19.6k	34	46	59	mA
Charge Termination Current	I_{BAT}	HCP = 110k		9		mA
Charge Termination Current	I_{BAT}	HCP = 210k		5		mA
Top Off Charge Droop Threshold	V_{BAT}		96	97	98	$\% \frac{V_{BAT}}{V_{CVL}}$
Battery Drain Current	I_{BAT}	$V_{BAT} = 4.2\text{V}$; battery charged		1	30	μA
		$V_{BAT} > V_{IN}$		5	30	μA
		SD = High (Shutdown Mode)		1	5	μA
LOGIC						
STAT Logic High Output	V_{STAT}	$V_{IN} = 5.0\text{V}$, $I_{DRV} = -10\text{mA}$	4.2	4.5	5	V
STAT Logic Low Output	V_{STAT}	$V_{IN} = 5.0\text{V}$, $I_{DRV} = 10\text{mA}$			0.5	V
Input Logic : SD, H/L, 20%	$V_{LOG(IN)}$	Logic Hi, Logic Lo	1.2		0.4	V
Input Current : SD, H/L	$I_{LOG(IN)}$	Logic Hi, $V_{LOG} = 2\text{V}$	0	2	4	μA
		Logic Lo, $V_{LOG} = 0\text{V}$	-2	0	2	μA
Input Current : 20%	$I_{20\%(IN)}$	Logic Hi, $V_{LOG} = 2\text{V}$	-2	-0.8	2	μA
		Logic Lo, $V_{LOG} = 0\text{V}$	-2	-0.8	2	μA
Output Logic : \overline{DCOK}	$V_{LOG(OUT)}$	Logic Hi, $I_{LOG} = 10\text{k}$ pullup to 3.3V	3.1			V
		Logic Lo, $I_{LOG} = 20\text{mA}$			0.5	V
BATTERY TEMPERATURE MONITOR						
Cold Temp Fault Threshold	V_{COLD}	Rising Threshold		$0.75 \times V_{IN}$		V
		Falling Threshold		$0.72 \times V_{IN}$		V
Hot Temp Fault Threshold	V_{HOT}	Falling Threshold		$0.28 \times V_{IN}$		V
		Rising Threshold		$0.30 \times V_{IN}$		V
TFB Disable Voltage	V_{DIS}		75	100	150	mV
Temp Loop Regulation			130	140	150	$^{\circ}\text{C}$



SIMPLIFIED BLOCK DIAGRAM

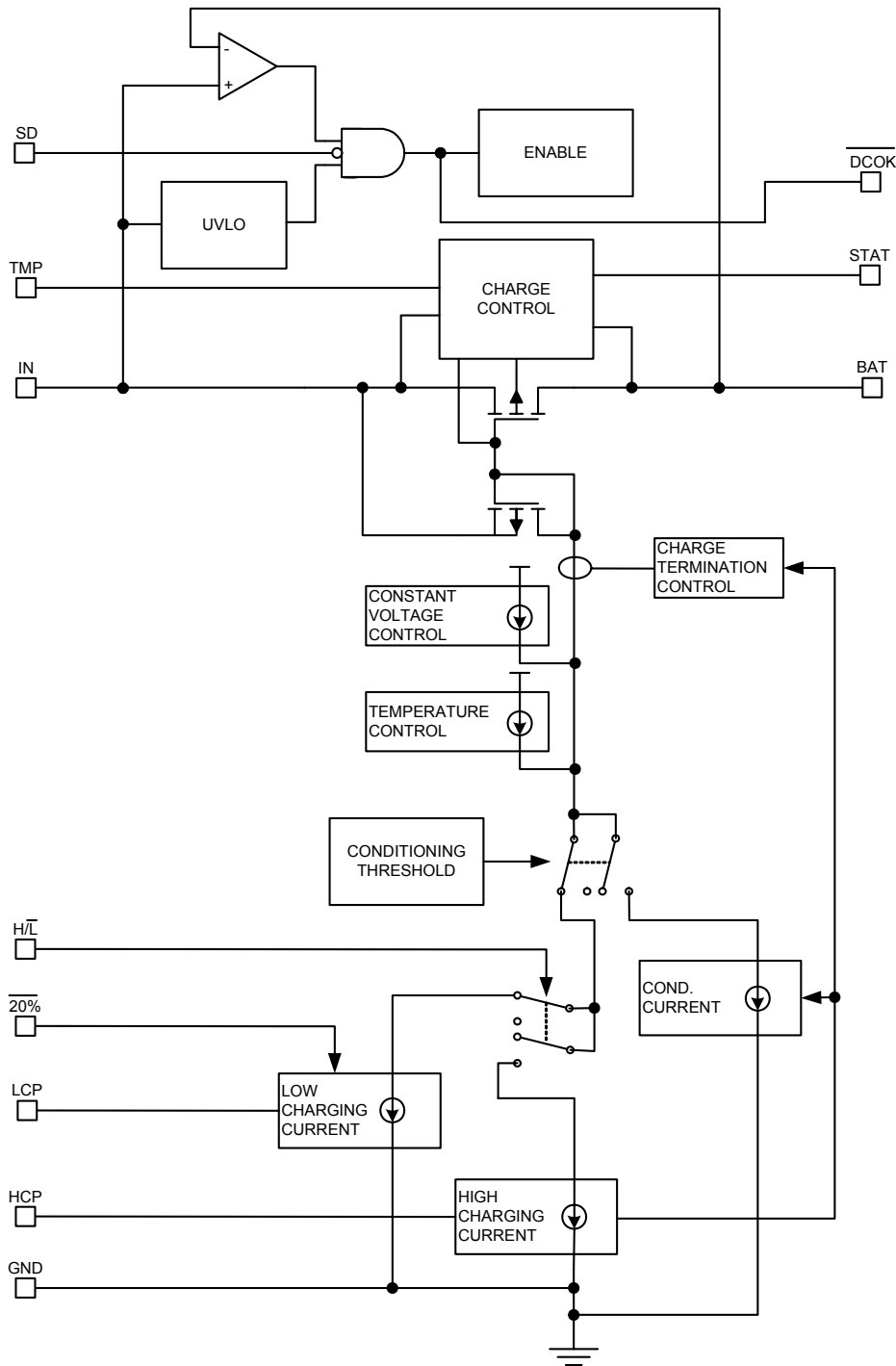



CONTROL LOGIC DIAGRAM

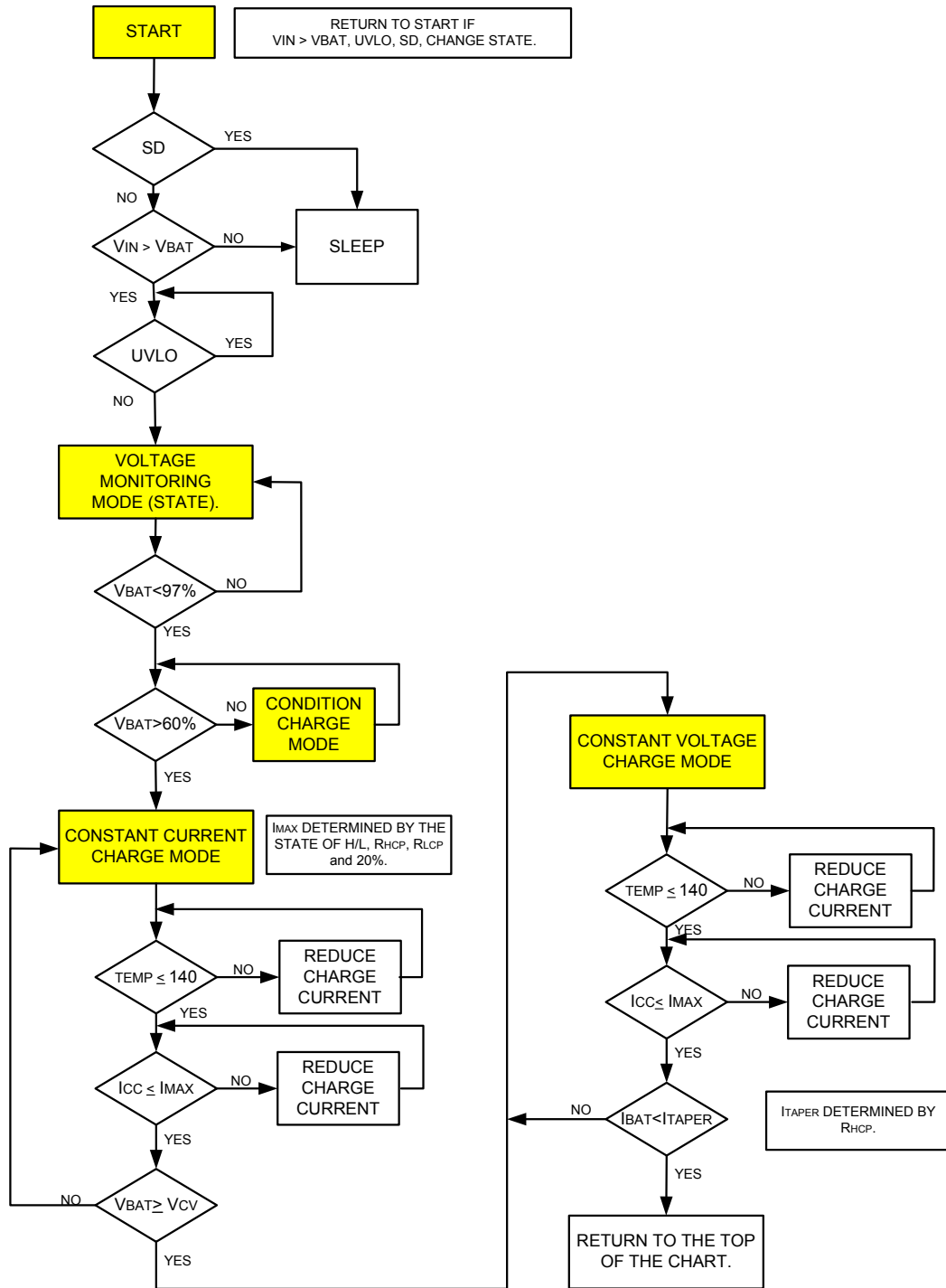

APPLICATION CIRCUITS

Figure 1 – Typical Application – 750mA adapter charge current and 500mA or 100mA maximum USB charge currents. A grounded spare pin in the USB power cable can be used to sense when the 500mA USB current power source is being used. This application also uses three LED indicators for Power attached, Battery Charging and Battery full. This configuration also implements circuitry to lockout battery charging if the battery is less than 0C or greater than 60C.



THEORY OF OPERATION

GENERAL DESCRIPTION

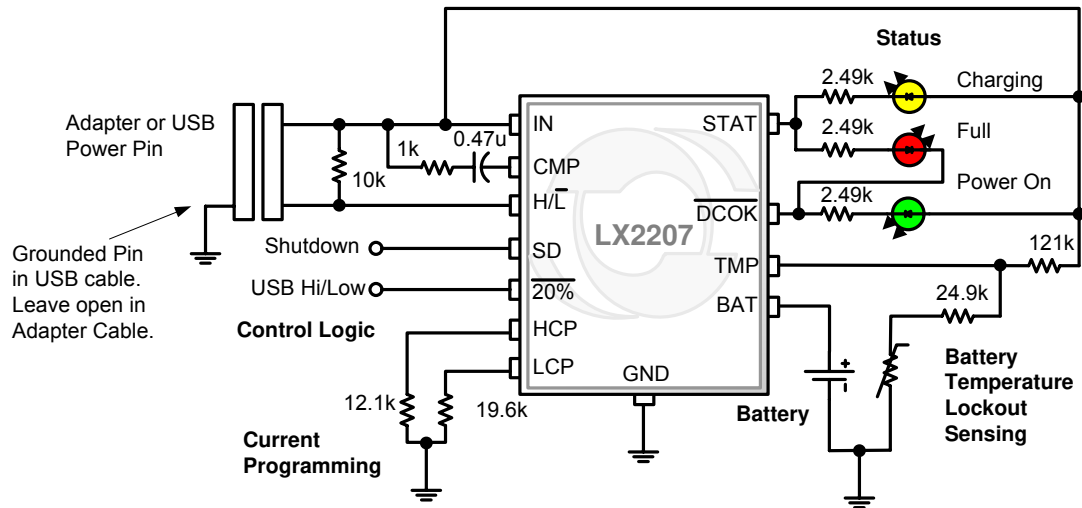
The LX2207 charges a single cell Lithium Ion battery using two steps: a constant current mode followed by a constant voltage mode. The maximum charging current during the Constant Current Mode of the charging profile can be logically set (using H/L) to two preprogrammed levels set by resistors connected to HCP and LCP (High and Low current). A 20% logic input selects either the full current set by the LCP resistor or 20% of that value. The charger will terminate constant voltage charging once the current drops below the taper current setting, which is 10% of the high charge current setting (determined by HCP resistor value).

CONDITIONING CURRENT CHARGE MODE

A conditioning current is applied to batteries that are deeply discharged and have a terminal voltage less than 60% of the constant voltage level. The conditioning current is 5% of the HCP programmable constant current level. Once the battery terminal voltage exceeds the conditioning current threshold, the full constant current level is applied (unless one of the other charger control loops limits charging current).

CHARGE TERMINATION MODE

To increase system battery life and avoid float charging, the LX2207 turns off the pass element once the battery is fully charged. The charge termination state occurs at the end of constant voltage mode. The value of the resistor connected to the HCP programming pin sets the termination current. The STAT pin changes state when charge cycle has completed.

TOP OFF CHARGE MODE

Once the charger has completed a charge cycle, if power remains applied, the LX2207 enters a Voltage Monitoring mode. In this mode the LX2207 monitors the battery terminal voltage and applies a top off charge if the battery voltage drops below the top of threshold.

ADAPTER OR USB SELECTION

The LX2207 supports battery charging from a system that provides adapter power or USB power using the same external connector. Figure 1 shows one example of a system using a special USB adapter cable to determine whether the power source is USB or Wall Adapter. Similarly, if the system processor senses the absence of USB data, it can logically set the H/L logic level high for the wall adapter.

USB CHARGE MODE AND CURRENT LIMIT

The LX2207 is fully compliant with, and supports, the USB specifications – the Low Power Peripheral (100mA) and High Power Peripherals (500mA). USB current levels can be set using the appropriate values for the LCP programming resistor. 20% logic input selects USB high/low charge currents. When the SD pin is pulled high, the USB input enters Suspend mode and will not present a load to the IN pin.

DCOK

The IN input is monitored and DCOK is set to a logic low to report the presence of the power source with sufficient voltage to charge the battery. The DCOK threshold is the larger of the UVLO threshold or the battery voltage.

PROTECTION FEATURES

Conditioning Current Mode – If the battery terminal voltage is less than 2.7V, the battery charger will reduce the charge current to 5%. This also protects the appliance from overheating by trying to drive the full charging current into a short circuited battery.

Under Voltage Lockout – The charge cycle will not start until the IN voltage rises above 3.8V. Hysteresis helps alleviate chattering on and off.

Thermal Control loop – If the power dissipation of the charger becomes excessive, the charge current will be reduced to prevent the die temperature from getting above 140°C. This does not cause the charge cycle to stop.

Reverse current blocking – If IN input is grounded, current will not flow from the BAT pin through the charger. No external blocking diode is required on the input.

Sleep Mode – If the SD pin is a logic high, the charger enters a sleep mode where a very low quiescent current prevents drain from the battery.

APPLICATION NOTE
LAYOUT

In the layout of the Printed Circuit Board (PCB) it is important to provide a solid path from the IC power and ground pins to the power and ground planes of the PCB to provide a good conduction path for heat. This insures the LX2207 stays cool and can provide the maximum charge current to minimize the time required to charge the battery.

For stability, and to reduce turn on – turn off transients, it is important to place capacitors close to the IN and BAT pins. Use a 10uF capacitor (X5R or X7R dielectric) for this purpose.

The CMP pin resistor and capacitor should be located close to the CMP pin. The CMP pin is located next to the IN pin to facilitate this. The 1K resistor is not required for stability, but reduces the inrush current into the CMP pin when the IN voltage transient is applied.

CURRENT PROGRAMMING RESISTORS

The LX2207 has two programming resistors to control the battery charging current during the constant current charging mode of the battery charging cycle. When the H/L pin is high (selecting the High Current charging mode), the charge current is determined by the value of the HCP programming resistor. The maximum charge current is determined by the programming current at either the HCP or LCP programming pins (depending on the state of H/L); the range of each of these channels is identical. The programming current is the HCP or LCP pin voltage (typically 1.25V) divided by the value of the programming resistor. For example, the HCP current with a 110k resistor to GND is:

$$I_{HCP} = \frac{1.25}{R_{HCP}} = \frac{1.25}{110k} = 11.4\mu A$$

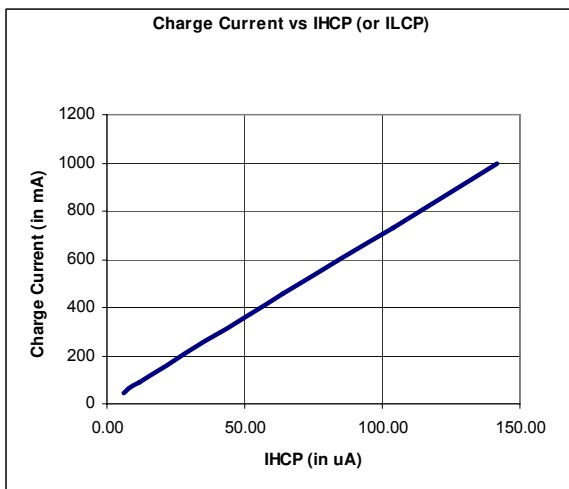

Using the table below it can be seen that for a programming current value of 11.4μA, the corresponding maximum charge current is 92mA.

The termination current determines the point at which the charge cycle is terminated and the battery is determined to be fully charged. The termination current is determined by the value of the HCP programming current as determined by the HCP programming resistor. For a value of IHCP = 11.4μA (as was used in the previous example), the termination current from the chart below can be seen to be 9mA.

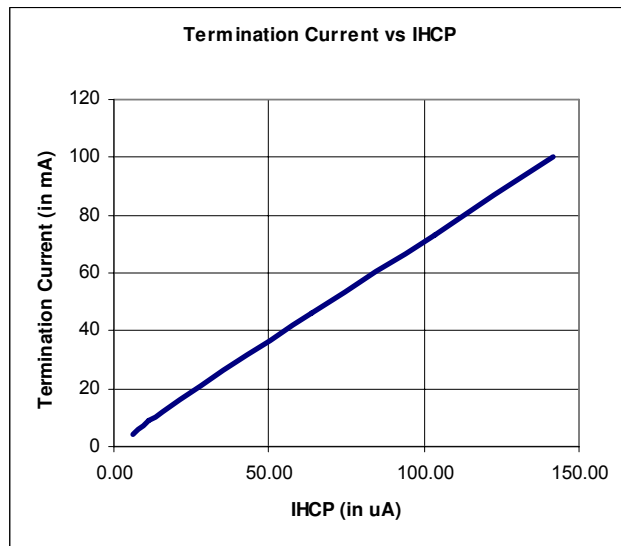

The termination current is always roughly 10% of the maximum charge current set by the HCP resistor.

INDEPENDENT TERMINATION CURRENT PROGRAMMING

For applications where a termination current other than 10% is required, the termination current can be set using the HCP resistor and the charge current can be set using the LCP resistor. In this case, the H/L pin is held low so that the HCP charge mode is never utilized. In this way the HCP pin only programs the termination current and conditioning current.

APPLICATION NOTE
BATTERY TEMPERATURE MONITOR

The LX2207 has an input to monitor the battery temperature during battery charging; this method assumes the battery pack contains a thermistor expressly for this purpose. A typical Lithium ion battery should only be charged from a range of 0°C to 60°C. For this calculation, a Vishay NTHS0402N01N1003J Thermistor was used. This thermistor is 327kΩ at 0°C, 100kΩ at 25°C and 24.9kΩ at 60°C. The thermistor must be biased with a Thevenin voltage source and series resistance to achieve the proper thresholds. A fixed value resistor is added in series with the thermistor to prevent it from becoming too low an impedance at high temperatures and causing the TMP input to default to off.

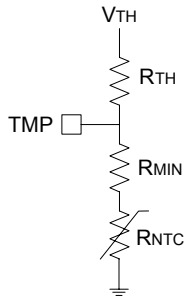

Using a value of R_{MIN} that is equal to the thermistor temperature at 60°C works well; therefore, for this example, set the value of R_{MIN} to 24.9k. This has the effect of adding 24.9k to the thermistor resistance values so it becomes 352kΩ at 0°C, 125kΩ at 25°C and 49.8kΩ at 60°C.

The equations for R_{TH} and V_{TH} are:

$$\frac{V_{TH}}{V_{IN}} = \frac{0.29 \times 0.74 \times (R_{T=0C} - R_{T=60C})}{(0.29 \times R_{T=0C}) - (0.74 \times R_{T=60C})}$$

$$= K = 0.99$$

$$R_{TH} = \left(\frac{K}{0.74} - 1 \right) \times R_{T=0C} = 121k$$

Where R at temperature is the sum of the thermistor plus R_{MIN} .

To finish the design it is necessary to create the Thevenin Voltage and resistance using a voltage divider from the input pin (IN).

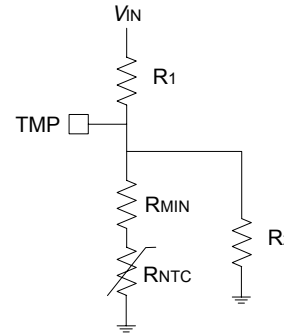

The values of $R1$ and $R2$ can be calculated as:

$$R_1 = \frac{R_{TH}}{K} = 122k$$

$$R_2 = \frac{R_1 \times R_{TH}}{R_1 - R_{TH}} = 14,800k$$

In this case, it is not necessary to use $R2$, because the value is so large it is insignificant. In this case, $R1 = R_{TH}$.

The final circuit for this example is:

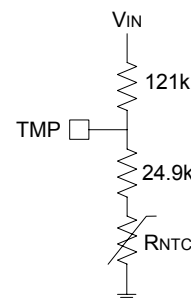

The TMP voltages with this circuit are:

TEMP (°C)	RNTC	VTMP (%VIN)
-20	971k	89%
0	327k	74%
25	100k	51%
60	24.9k	29%
80	12.6k	24%

APPLICATION NOTE
POWER STATUS INDICATORS

The STAT pin is designed to source or sink current. LEDs can be configured to indicate charging or battery full. The battery full indicator can be connected to DCOK rather than GND to insure it is off when the input power is removed and the STAT pin and DCOK pin go to a high impedance state.

Conditions	STAT
Charge in process	Low
Charge completed	High

INPUT POWER SOURCE DETECTION

In order to detect when the input power source has been removed, the LX2207 requires that a small current (up to 200uA) momentarily flow out of the IN pin (in the reverse direction). Once detected, the reverse IN current is shut off (the IN pin becomes a very high impedance until an input power source is later reapplied). In most applications, there is sufficient loading on the IN pin from external circuitry to accomplish this, which includes the "Full" and/or "Power On" LED loads and the TFB resistor string. If there is no external load on the IN pin, then it is recommended to provide a 15k resistor from IN to GND as shown below.

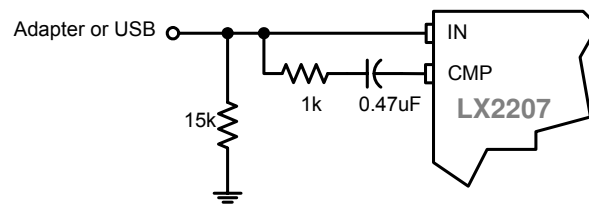
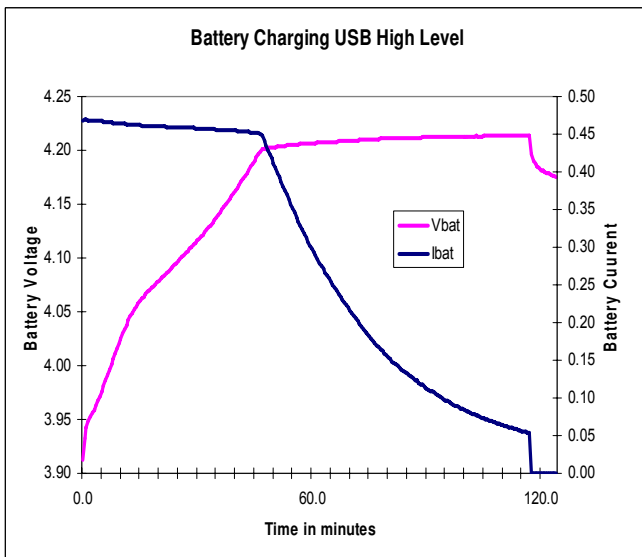
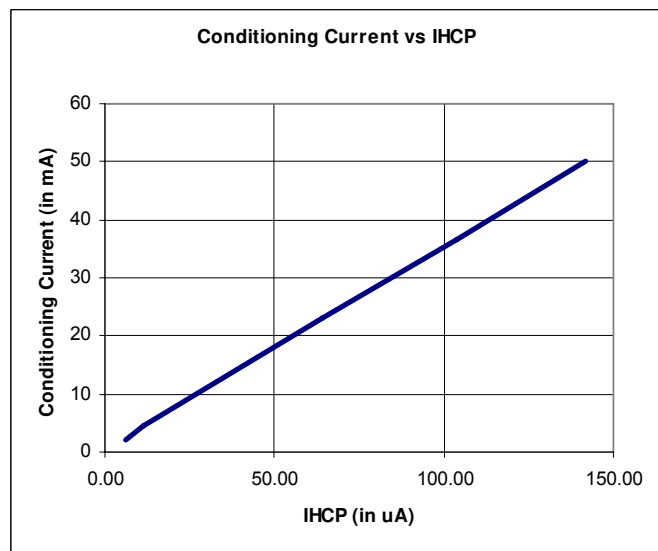
CHARGING PROFILE

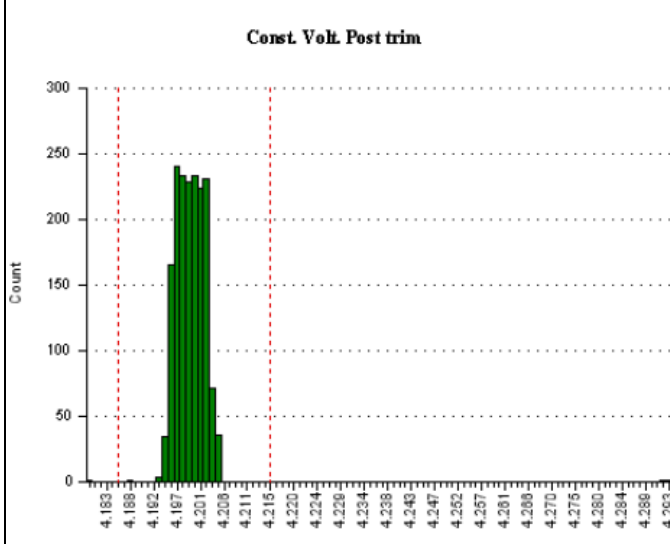
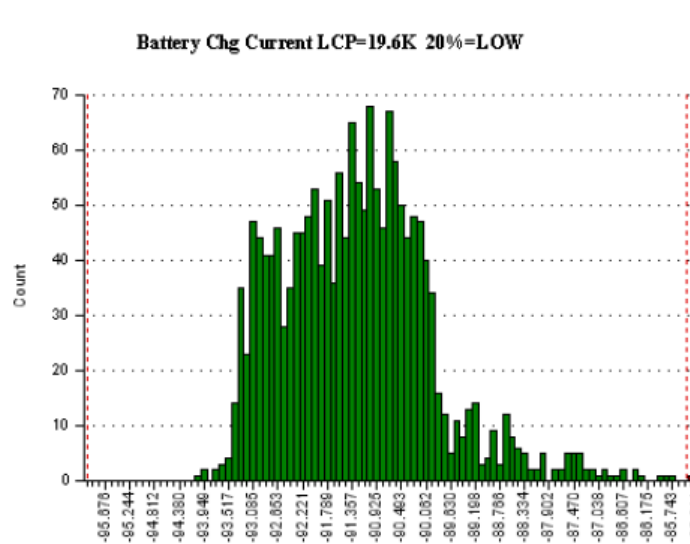
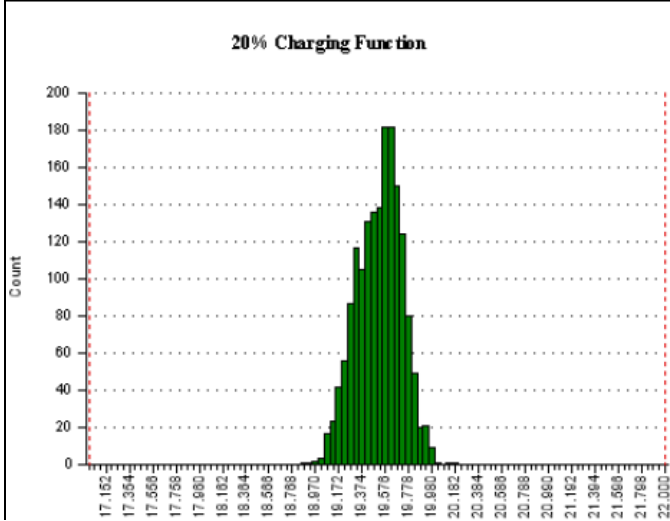
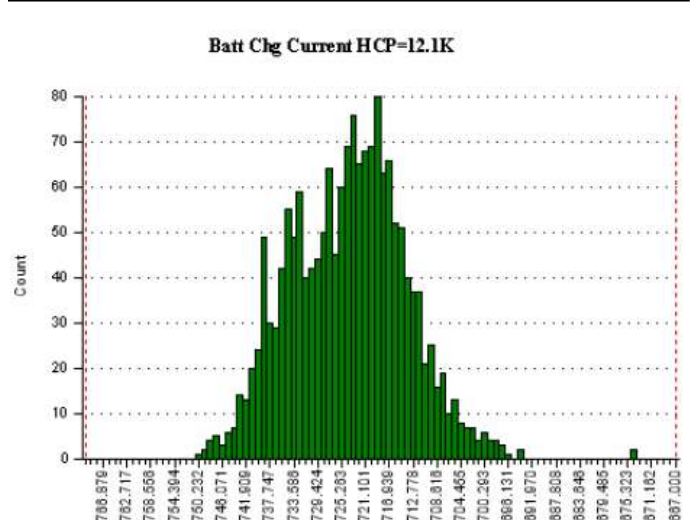
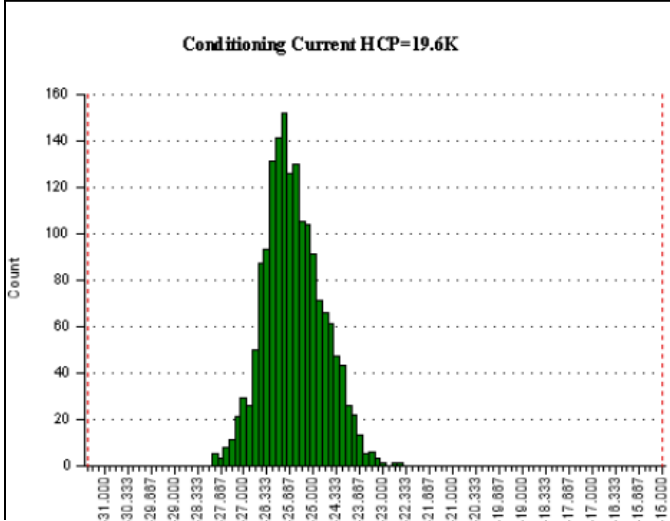
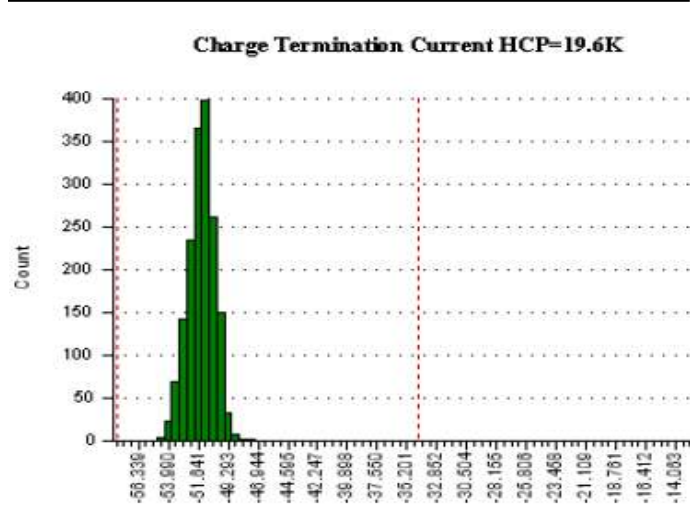
CONDITIONING CURRENT

**CONSTANT VOLTAGE****CONSTANT CURRENT (USB LOW)****20% CHARGE RATIO****ADAPTER CHARGE CURRENT****CONDITIONING CURRENT****TERMINATION CURRENT**



Three Level Lithium Ion Battery Charger

PRODUCTION DATA SHEET

COLD TMP THRESHOLDS (VIN = 5V)

HOT TMP THRESHOLDS (VIN = 5V)

Rising voltage:

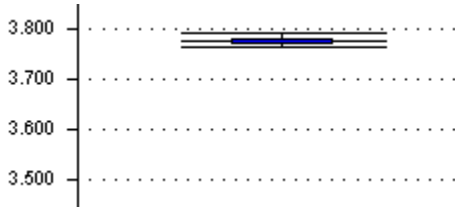

Rising voltage:

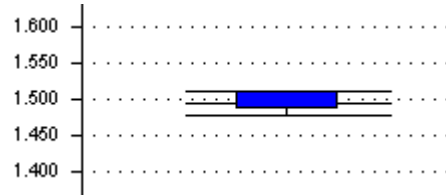

Falling Voltage:

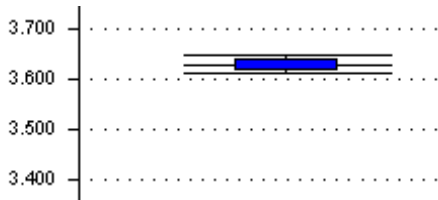

Falling Voltage:

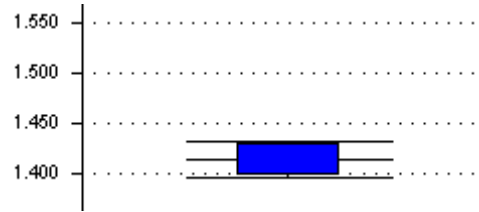

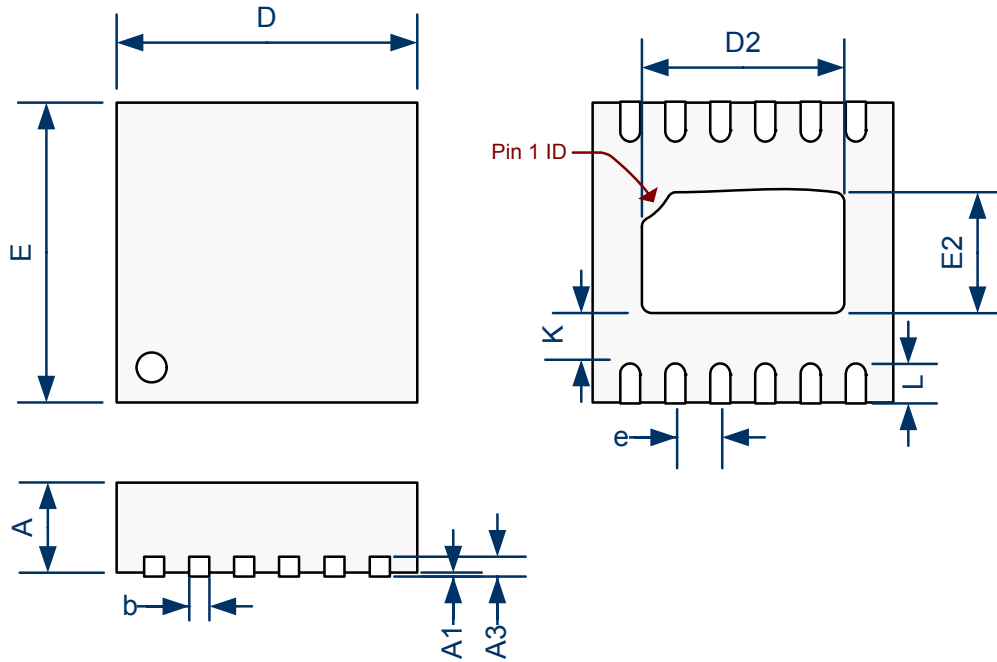
**PACKAGE DIMENSIONS****LD****12-Pin Plastic MLP Dual Exposed Pad**

Dim	MILLIMETERS		INCHES	
	MIN	MAX	MIN	MAX
A	0.80	1.00	0.031	0.039
A1	0.00	0.05	0.000	0.002
A3	0.20 REF		0.008 REF	
D	3.00 BSC		0.118 BSC	
E	3.00 BSC		0.118 BSC	
D2	1.87	2.12	0.074	0.083
E2	1.06	1.31	0.042	0.052
e	0.45 BSC		0.018 BSC	
K	0.20 MIN		0.008 MIN	
L	0.30	0.50	0.012	0.020
b	0.15	0.25	0.06	0.010

Note:

1. Dimensions do not include mold flash or protrusions; these shall not exceed 0.155mm (.006") on any side. Lead dimension shall not include solder coverage.



NOTES