

DESCRIPTION

Demonstration circuit board DC1358A is a Dual Hot Swap Controllers featuring the LTC1647.

DC1358 facilitates evaluation of the LTC1647-1 performance characteristics including supplies ramp-up transients, steady state operation, and overcurrent fault conditions.

DC1358 is assembled to operate with +5.0V rail, with 5A maximum current for first channel and 0.5A maximum current for second one.

The board contains one LTC1647-1 Controller, two +5V rail channels, input clamp, two input voltage dividers for providing ON1 and ON2 control signals, circuit for implementing sequencing. On board LEDs indicate input supply presence and outputs state. The rail voltage and the Vcc are common for both channels.

LT, LTC, LTM, LT, Burst Mode, OPTI-LOOP, Over-The-Top and PolyPhase are registered trademarks of Linear Technology Corporation. Adaptive Power, C-Load, DirectSense, Easy Drive, FilterCAD, Hot Swap, LinearView, μ Module, Micropower SwitcherCAD, Multimode Dimming, No Latency $\Delta\Sigma$, No Latency Delta-Sigma, No RSENSE, Operational Filter, PanelProtect, PowerPath, PowerSOT, SmartStart, SoftSpan, Stage Shedding, SwitcherCAD, ThinSOT, UltraFast and VLDO are trademarks of Linear Technology Corporation. Other product names may be trademarks of the companies that manufacture the products.

PERFORMANCE SUMMARY Specifications are at TA = 25°C

SYMBOL	PARAMETER	CONDITIONS	MIN	TYP	MAX	UNITS
V _{CC}	Input Supply Range		2.7		16.5	V
V _{LKO}	V _{CC} Undervoltage Lockout	Coming Out of UVLO (Rising V _{CC})	2.30	2.45	2.6	V
V _{LKH}	V _{CC} Undervoltage Lockout Hysteresis			210		mV
V _{CB}	Circuit Breaker Trip Voltage	V _{CB} = V _{CC} - V _{SENSE}	40	50	60	V
I _{CP}	Gate X Output Current	ONX High, FAULT X High, V _{GATE} = GND (Sourcing), ONX Low, FAULT X High, V _{GATE} = V _{CC} (Sinking), ONX High, FAULT X Low, V _{GATE} = 15V (Sinling),	6	10 50 50	14	μ A μ A μ A
Δ V _{GATE}	External MOSFET Gate Drive (V _{GATEN} - V _{CC})	V _{CC} = 5.0V	10	13	17	V
V _{ONHI}	ONX Threshold High		1.20	1.21	1.25	V
V _{ONLO}	ONX Threshold Low		1.17	1.21	1.250	V
V _{ONHYST}	ONX Hysteresis			70		mV
t _{FAULT}	Circuit Breaker Delay Time	V _{CC} - V _{SENSE} = 0 to 100mV				μ s
t _{RESET}	Circuit Breaker Reset Time	ONX High to Low, to FAULT High		50	100	μ s
t _{ON}	Turn-ON Time	ONX Low to High, to GATE X ON		2		μ s
t _{OFF}	Turn-OFF Time	ONX High to Low, to GATE OFF		1		μ s

OPERATING PRINCIPLES

The LTC1647-1 is a low voltage dual hot swap controller has 2.7V to 16.5V operating range. There is a common Vcc pin for both channels and separate ON pins for control signals to enable and disable channels. In the DC1358 channels can easily be readjusted for any volt-second channel sets a 0.5A circuit breaker threshold.

age between 2.7V and 16.5V by replacing ON signal dividers. The DC1358 as supplied by the factory is assembled with the IRF7413Z MOSFETs in an SO-8 package. 10m Ω current sense resistor in the first channel sets a 5A circuit breaker threshold and 100m Ω resistor in the

QUICK START PROCEDURE

Demonstration circuit 1358 is easy to set up to evaluate the performance of the LTC1647. Refer to Figure 1 for proper measurement equipment setup and follow the procedure below.

1. Place jumpers in the following positions:

JP1 OFF1

JP2 OFF2

JP3 NO OFF

JP4 NO SEQUENCE

2. With power off, connect the +5V power supply output terminals to the Vcc 5V (E3) and GND (E6) turrets.
3. Turn on the 5V power supply and turn on switch SWPS and verify LED D2 VIN lights and no output voltages at the VOUT1 at the VOUT2 turrets.

4. Place jumper JP1 Control1 in the ON1 position and verify output voltage at the VOUT1 turret and green LED D1 VOUT1 should light.
5. Place jumper JP2 Control2 in the ON2 position and verify output voltage at the VOUT2 turret and green LED D4 VOUT2 should light.
6. Check the current limit in both channels using electronics or resistive load in the steady state (after power-up transient completed). First channel should limit current in the range of 3.95-6.12A, second one in the range of 0.395-0.612A.
7. Check with a scope the output voltage slew rates, when channels power-up with no load. It should take (28-100)ms for first channel output voltage to rise and (2.8-10)ms for second channel.

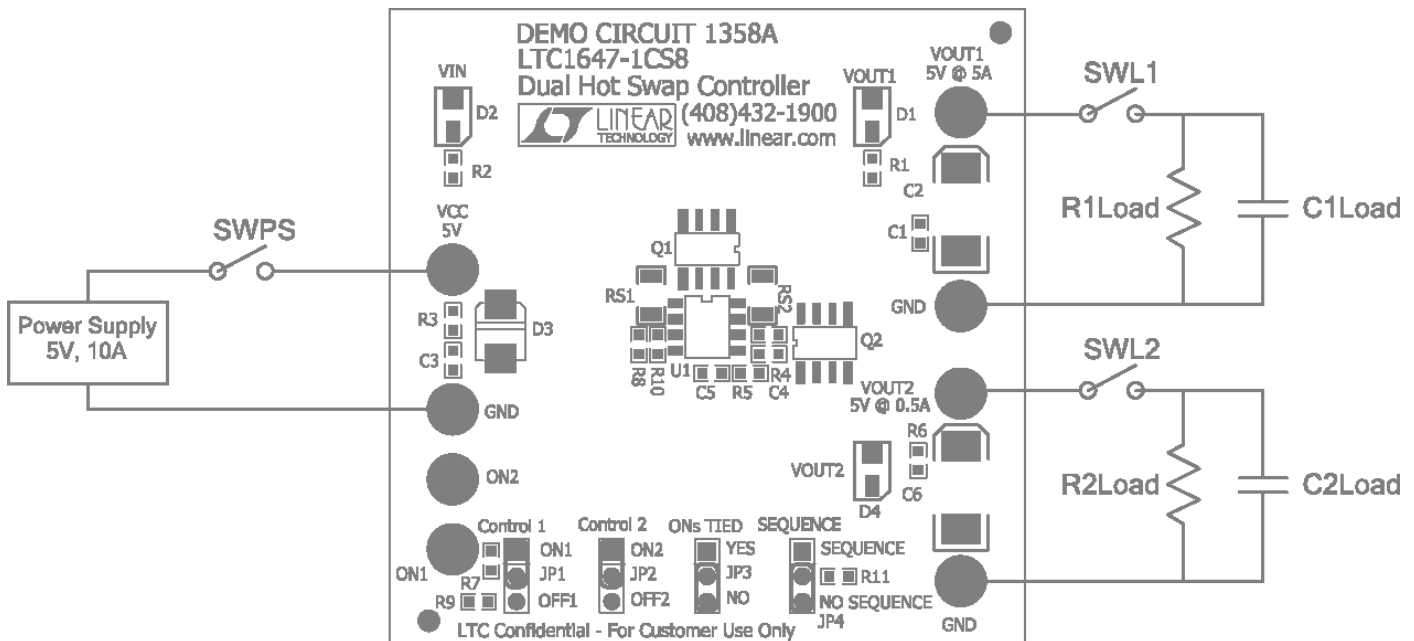
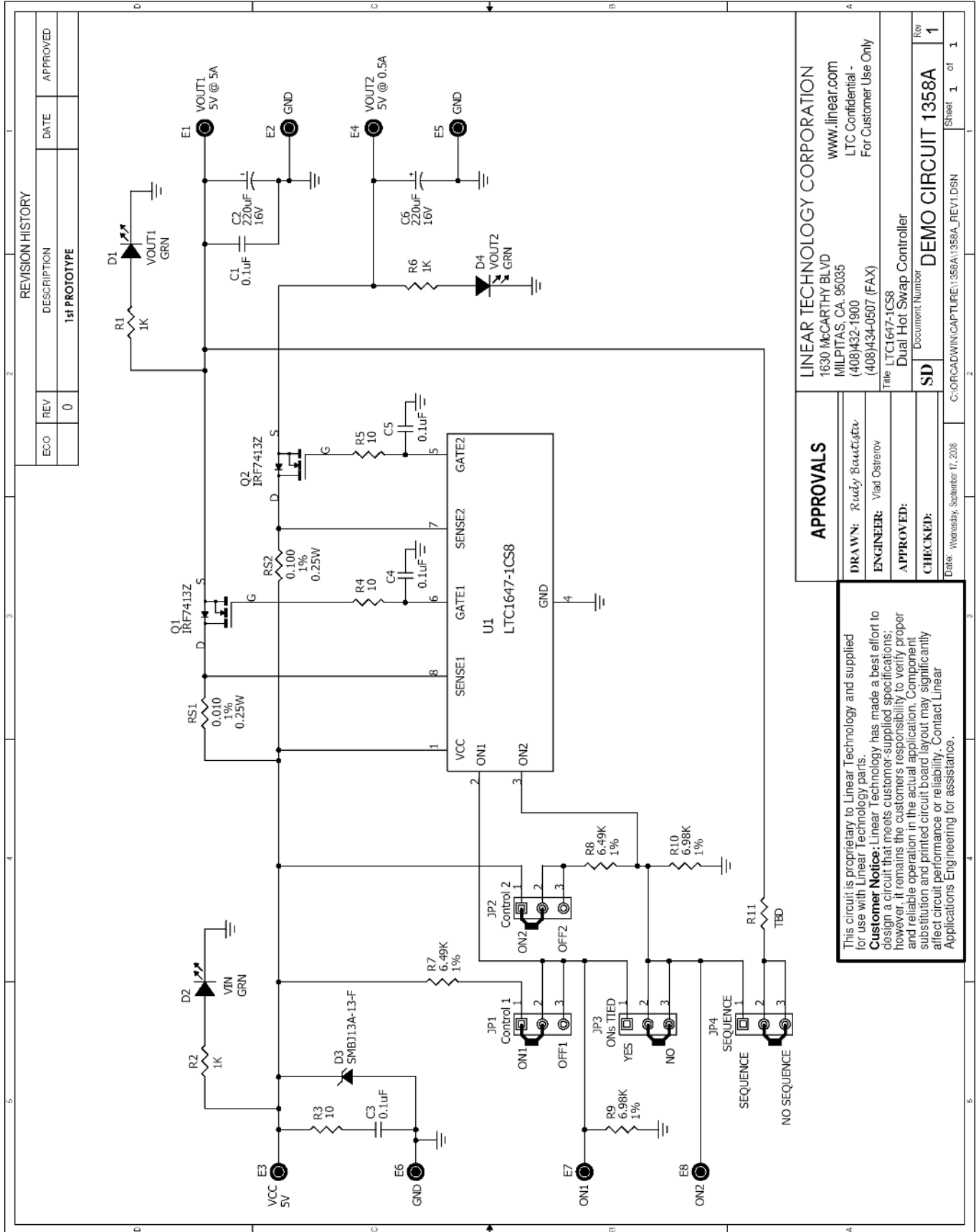

Figure 1. Proper Measurement Equipment Setup



REVISION HISTORY		
ECO	REV	DATE
	0	
DESCRIPTION		
1st PROTOTYPE		
		APPROVED

APPROVALS	
LINEAR TECHNOLOGY CORPORATION 1630 McCARTHY BLVD MILPITAS, CA, 95035 www.linear.com	
DRAWN: <i>Rudy Bouchard</i>	
ENGINEER: <i>Vlad Ostrov</i>	
APPROVED:	
CHECKED:	
Date: <i>Wednesday, September 17, 2008</i>	C:\ORCAD\WINCAPTURE\1356A\1356A_REV1.DSN
Document Number	1
SD	1
DEMOCIRCUIT 1358A	1
Sheet 1	of 1

This circuit is proprietary to Linear Technology and supplied for use with Linear Technology parts.
Customer Notice: Linear Technology has made a best effort to design a circuit that meets customer-supplied specifications; however, it remains the customer's responsibility to verify proper and reliable operation in the actual application. Component substitution and printed circuit board layout may significantly affect circuit performance or reliability. Contact Linear Applications Engineering for assistance.

Bill Of Material

Item	Qty	Reference	Part Description	Manufacturer / Part #
1	4	C1,C3,C4,C5	Cap., X7R 0.1uF 25V 10%	AVX 06033C104KAT2A
2	2	C6,C2	Cap., Tant. 220uF 16V 20%	AVX TPSE227M016R0100
3	3	D1,D2,D4	LED, GRN	Panasonic LN1351CTR .
4	1	D3	Voltage Supressor, 13V	Diodes Inc. SMBJ13A-13-F
5	8	E1,E2,E3,E4,E5,E6,E7,E8	Turret, Testpoint	Mill Max 2501-2-00-80-00-00-07-0
6	4	JP1,JP2,JP3,JP4	Headers, 3 Pins 2mm Ctrs.	Samtec TMM-103-02-L-S
7	2	Q2,Q1	N-Chan. Mosfet, 30V	International Rect. IRF7413ZT
8	1	RS1	Res., 0.010 0.25W 1%	Vishay Dale WSL1206R0100FEA
9	1	RS2	Res., 0.100 0.25W 1%	Vishay Dale WSL1206R1000FEA
10	3	R1,R2,R6	Res., Chip 1K 0.06W 5%	Vishay CRCW06031K00JNEA
11	3	R3,R4,R5	Res., Chip 10 0.06W 5%	Vishay CRCW060310R0JNEA
12	2	R7,R8	Res., Chip 6.49K 0.06W 1%	Vishay CRCW06036K49FKEA
13	2	R9,R10	Res., Chip 6.98K 0.06W 1%	Vishay CRCW06036K98FKEA
14	0	R11 (Opt)	Res., 0603 TBD	
15	1	U1	I.C., Dual Hot Swap Controller	Linear Tech. Corp. LTC1647-1CS8
16	4	XJP1,XJP2,XJP3,XJP4	Shunt, 2mm Ctrs.	Samtec 2SN-BK-G
17	1		FAB, 1358A_Rev1.PCB	DEMO CIRCUIT #1358A
18	1		STENCIL	STENCIL 1358A