

Data Sheet

AT-3411-T-HT-LW110-R

PUI Audio's **High Temperature** line of products is designed to withstand ultra-wide operating temperatures. The **AT-3411-T-HT-LW110-R** is designed for high output at 1100Hz in a small package.

- Wide -30°C to +85°C operating temperature
- ≥85 dB output at 10cm with 9 Vp-p input
- Low current draw of ≤9 mA
- 110mm long lead wires and mounting flange for easy integration

Specifications

Parameters	Values	Units
Rated Voltage	9	Vp-p
Operating Voltage Range	1~30	Vp-p
Current Draw at Rated Voltage	≤9	mA
Capacitance @ 100Hz	50000±30%	pF
Minimum SPL @ 10cm	≥85	dBA
Resonant Frequency	1100±500	Hz
Housing Material	Black ABS	-
Weight	6	Grams
Acceptable Soldering Methods	Hand Solder	-
Environmental Compliances	RoHS	-
Storage Temperature	-40 ~ +85	°C
Operating Temperature	-30 ~ +85	°C

Measurement Method (9 Vp-p, 1100Hz, 50% duty cycle square wave with SPL meter spaced at 10cm)

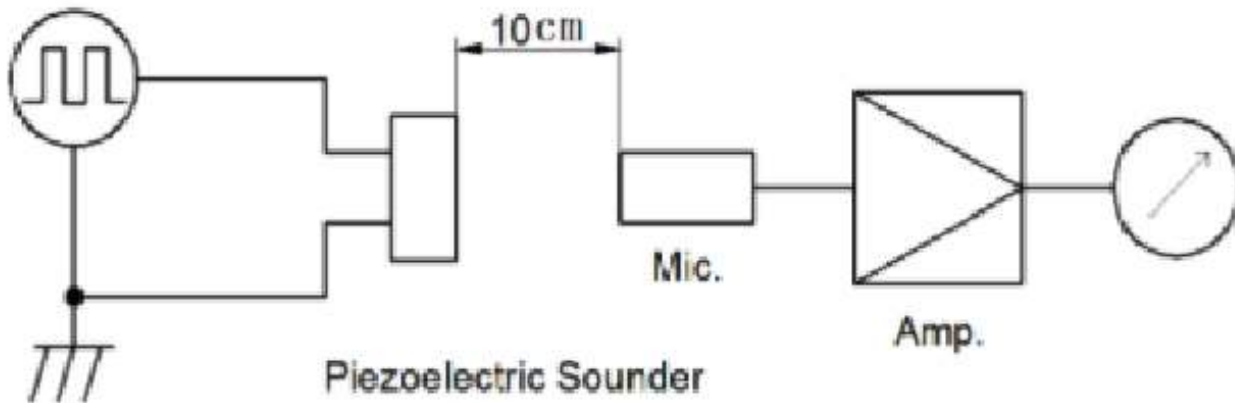

Typical Frequency Response (9 Vp-p sine-sweep with microphone spaced at 10cm)

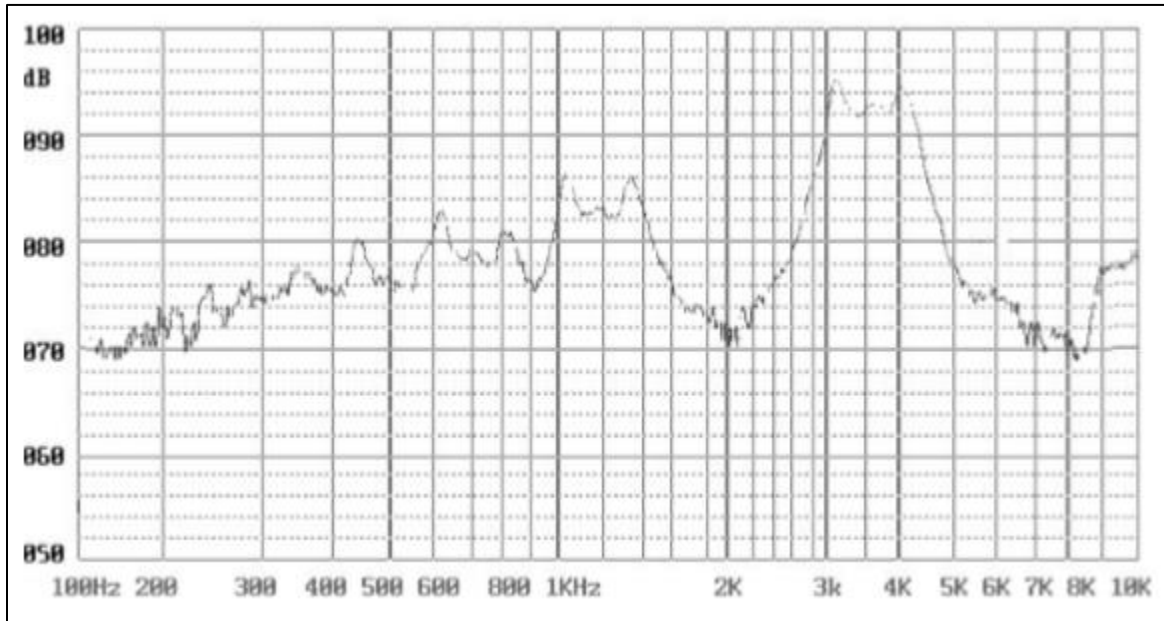

Reliability Testing

Type of Test	Test Specifications
High Temperature Test	+85±2°C, 96HRS
Low Temperature Test	-30±2°C, 96HRS
Humidity Test	40±2°C, 93 (+2/-3) %RH, 96HRS
Temperature Cycle Testing	-30±2°C, 30 minutes room temp. 15 minutes +85±2°C, 30 minutes room temp. 15 minutes 5 cycles
Vibration Test	Test directions of X, Y, and Z (a total of 0.5 hour). Sweep time (from 10 to 55 Hz and then from 55 to 10 Hz) under an amplitude of 1.0 mm for 1 minute.
Drop Test	Drop 3 times from height of 70cm onto the surface of 10mm thick wooden board.

After being placed for 2 to 4hrs at room temp, the product shall meet specifications, except the SPL should be in ± 10dB compared with initial one

Dimensions (Tolerance: $\pm 0.5\text{mm}$ unless otherwise specified)

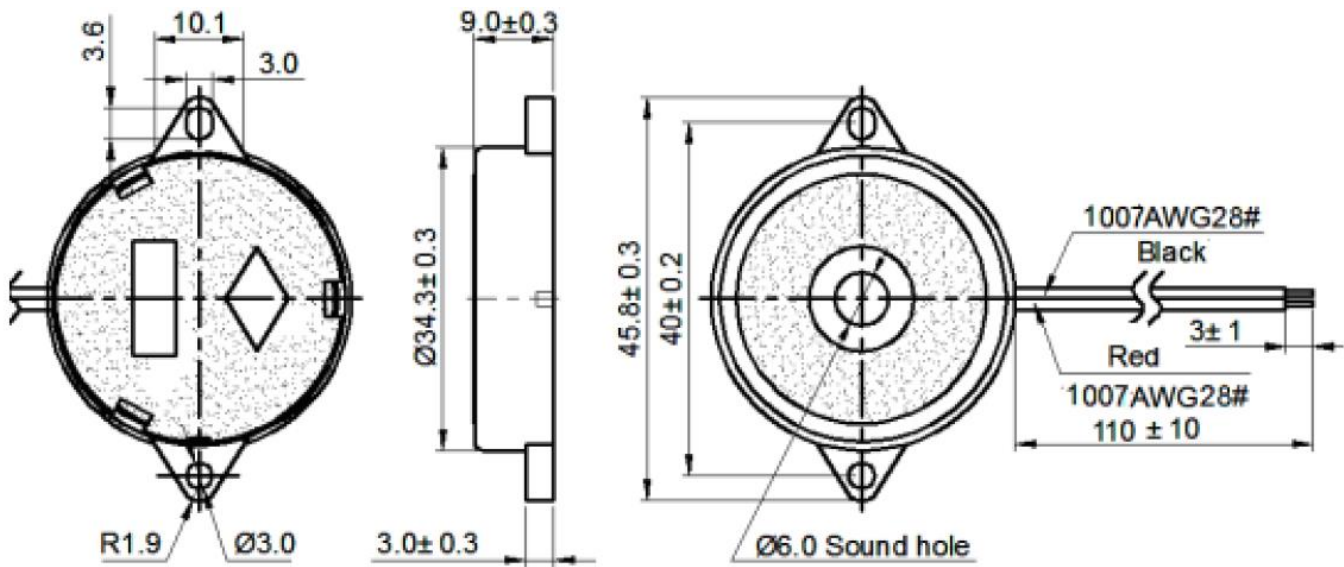

Packaging

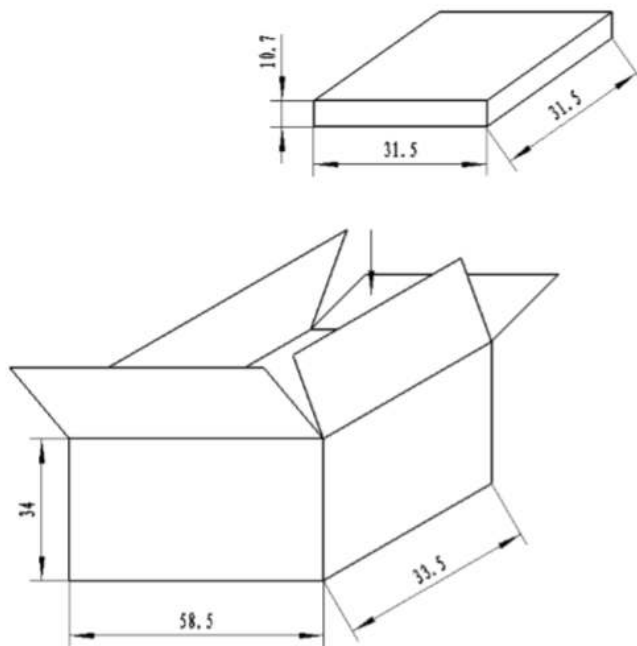

NOTES:

- 1.300 PCS per box
- 2.Total 5 boxes per carton
- 3.Total 1500 PCS per carton
- 4.Volume: $58.5 \times 33.5 \times 34\text{cm}$

Specifications Revisions

Revision	Description	Date
-	Released from Engineering	3/9/2020

Note:

- 1. Unless otherwise specified:
 - A. All dimensions are in millimeters.
 - B. Default tolerances are $\pm 0.5\text{mm}$ and angles are $\pm 3^\circ$.
- 2. Specifications subject to change or withdrawal without notice.