

REVISONS		DATE	OWN	APPR
DF	FO			
C	REV PER	063D-0417-02	10-02	CT DN

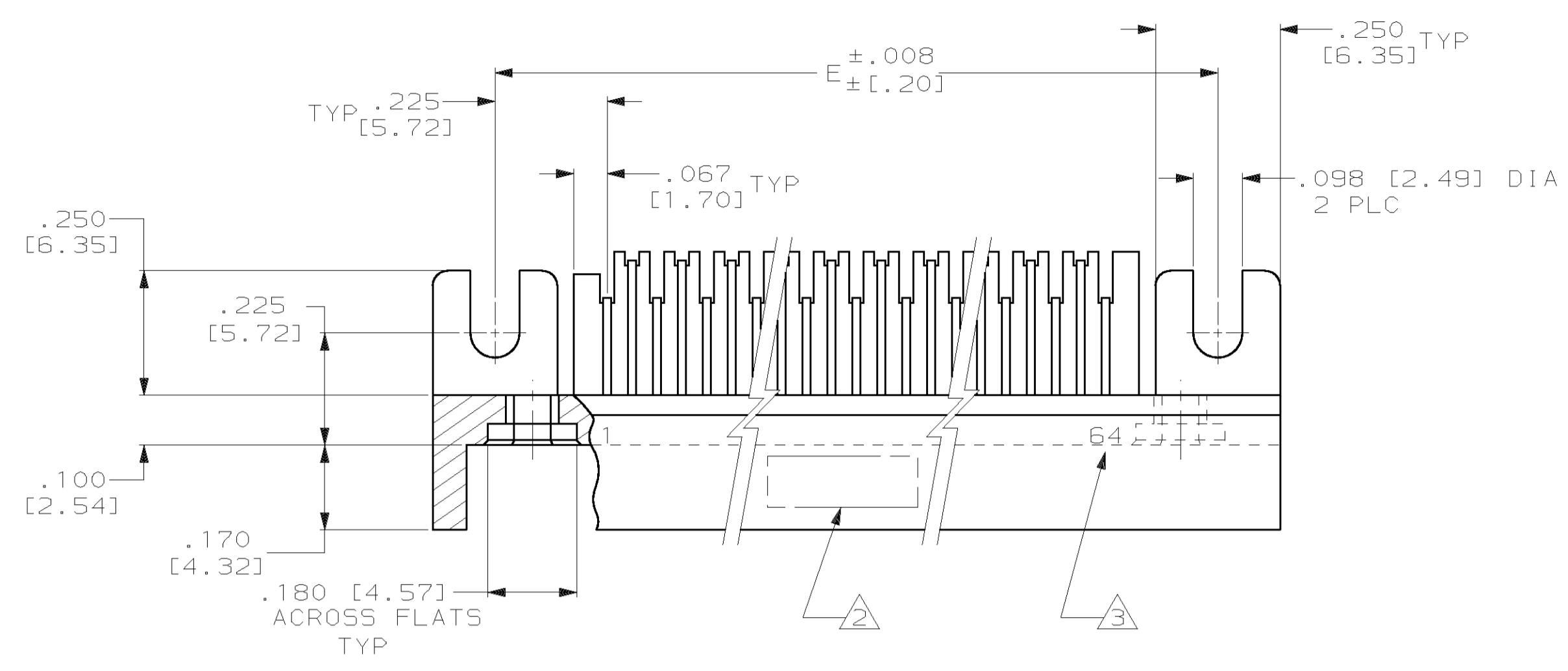

- CONNECTOR MEETS ALL APPLICABLE REQUIREMENTS OF MIL-C-55302.
- AMP,00779, AMP PART NO, CUSTOMER PART NO. (PER TABLE) AND DATE CODE MARKED IN THIS APPROXIMATE AREA.
- END CAVITY IDENTIFICATION NUMBERS (PER TABLE) MARKED THIS SIDE ONLY.
- EPOXY, FOR CONTACT RETENTION AND SEALING, APPLIED TO CONTACT ROWS IN THIS AREA.
- FINISH: PLATED GOLD .000050 THK PER MIL-G-45204 ON MATING END FOR A LENGTH OF .100 MIN, TAILS PLATED TIN-LEAD .000120 THK, ALL OVER NICKEL .000050 THK PER QQ-N-290.
- SPACE IN TONGUE NOT APPLICABLE FOR 20 THRU 50 POSITIONS.
- PART MUST PASS SEALING EFFECTIVENESS TEST PER 109-9005.
- HOUSING MATERIAL: LIQUID CRYSTAL POLYMER PER MIL-M-24519, GLCP-30F; COLOR: GRAY.

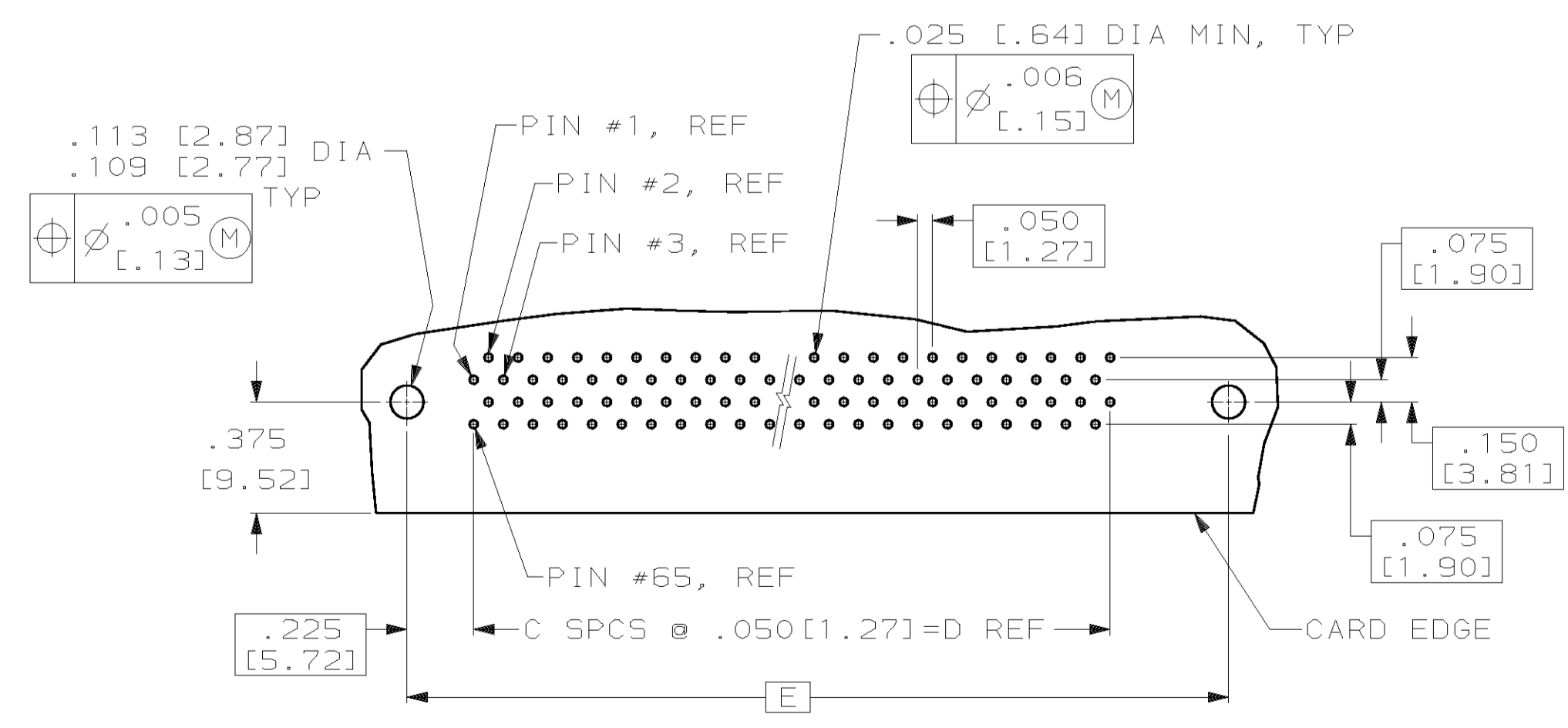
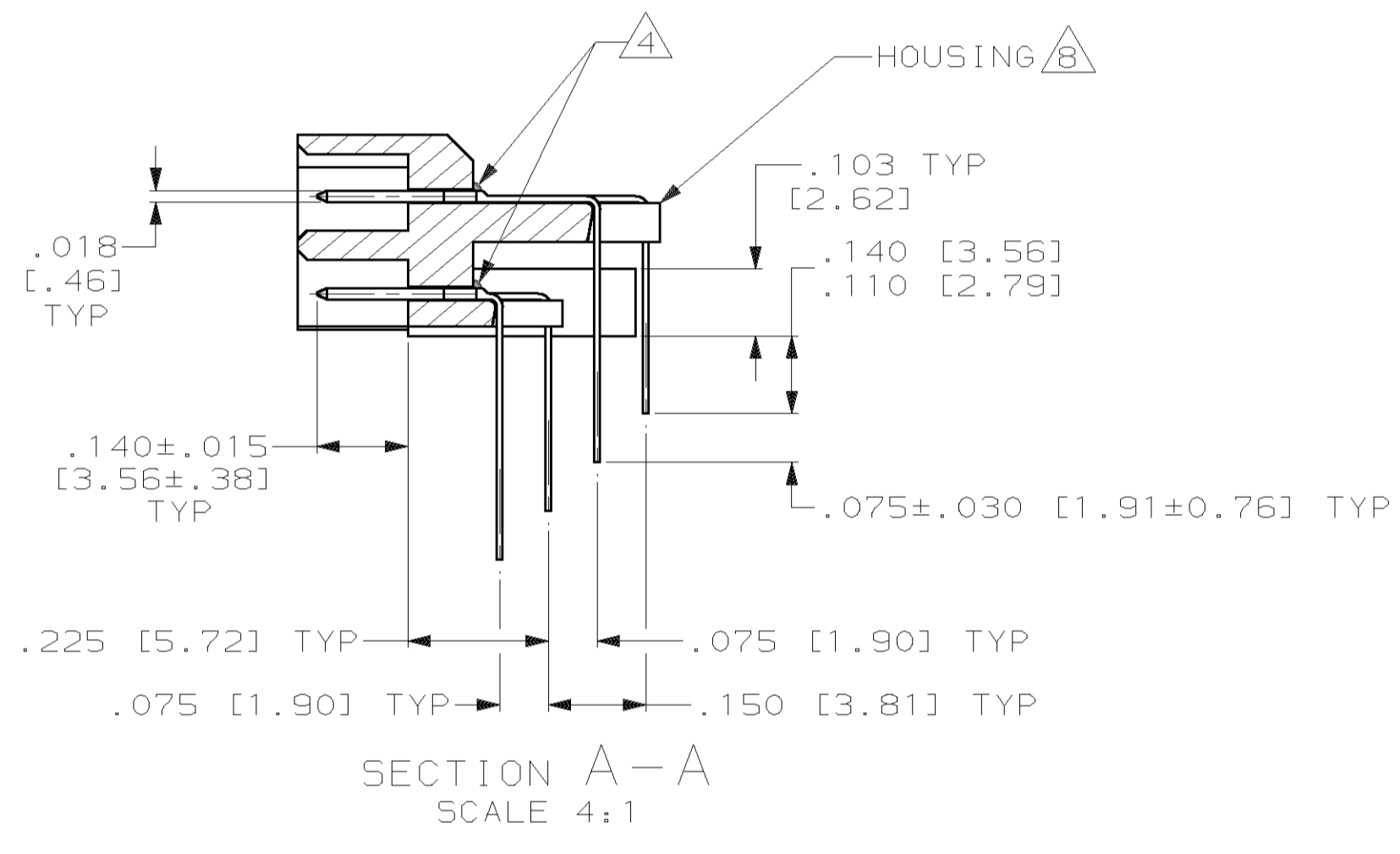
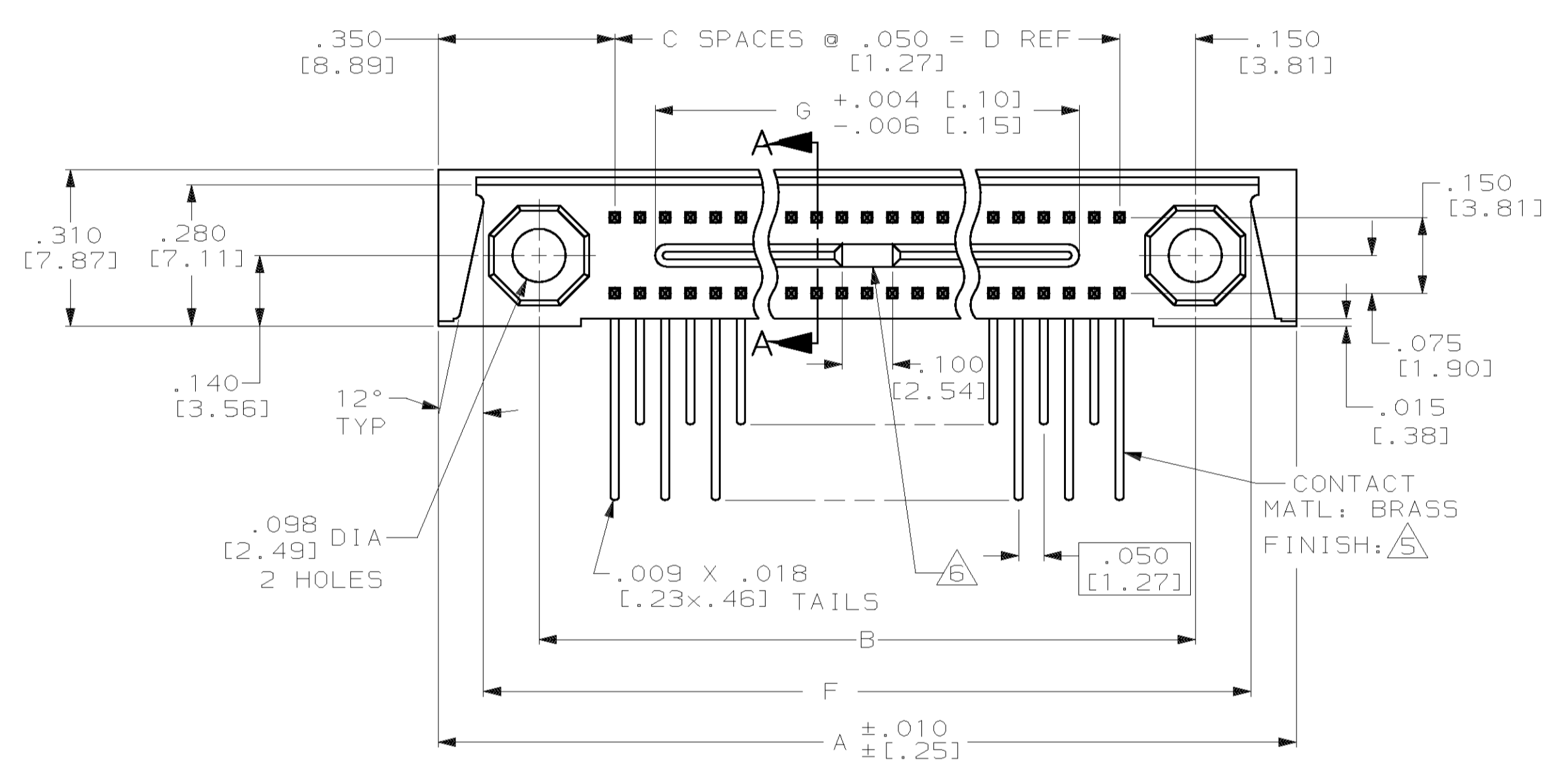

7060015-8	1 - 45	2.040 [51.82]	2.720 [69.09]	2.650 [67.31]	2.200 [55.88]	44	2.500 [63.50]	2.900 [73.66]	90	443261-4
7060015-1	1 - 10	.290 [7.37]	.970 [24.64]	.900 [22.86]	.45 [11.43]	9	.750 [19.05]	1.150 [29.21]	20	443261-3
7060015-2	1 - 15	.540 [13.72]	1.220 [30.99]	1.150 [29.21]	.700 [17.78]	14	1.000 [25.40]	1.400 [35.56]	30	443261-2
7060015-11	1 - 64	2.990 [75.95]	3.670 [93.22]	3.600 [91.44]	3.150 [80.01]	63	3.450 [87.63]	3.850 [97.79]	128	443261-1
CUSTOMER PART NUMBER	CAVITY IDENT	G	F	E	D	C	B	A	NO OF POSN	PART NUMBER

DIMENSIONS:		TOLERANCES UNLESS OTHERWISE SPECIFIED:		DWN I. ALEXANDER 3-7-95	
mm		0 PLC ±-		CHK D. GUTTER 3-7-95	
1 PLC ±-		2 PLC ±-		APPROV D. GUTTER 3-7-95	
3 PLC ±-		4 PLC ±-.005 [0.13]		NAME	
ANGLES ±-		FINISH		PRODUCT SPEC	
MATERIAL		FINISH		APPLICATION SPEC	
WEIGHT		SCALE		SIZE	
CUSTOMER DRAWING		SCALE 4:1		CAGE CODE	
		SHEET 1 OF 1		DRAWING NO	
		REV C		AMP Incorporated Harrisburg, PA 17105-3608	
				PIN HEADER ASSEMBLY, MINI-BOX, RIGHT ANGLE	
				A1 00779 C-443261	