

National Semiconductor is now part of
Texas Instruments.

Search <http://www.ti.com/> for the latest technical
information and details on our current products and services.

LM160/LM360 High Speed Differential Comparator

General Description

The LM160/LM360 is a very high speed differential input, complementary TTL output voltage comparator with improved characteristics over the μ A760/ μ A760C, for which it is a pin-for-pin replacement. The device has been optimized for greater speed, input impedance and fan-out, and lower input offset voltage. Typically delay varies only 3 ns for overdrive variations of 5 mV to 400 mV.

Complementary outputs having minimum skew are provided. Applications involve high speed analog to digital converters and zero-crossing detectors in disk file systems.

Features

- Guaranteed high speed: 20 ns max
- Tight delay matching on both outputs
- Complementary TTL outputs
- High input impedance
- Low speed variation with overdrive variation
- Fan-out of 4
- Low input offset voltage
- Series 74 TTL compatible

Connection Diagrams

Metal Can Package

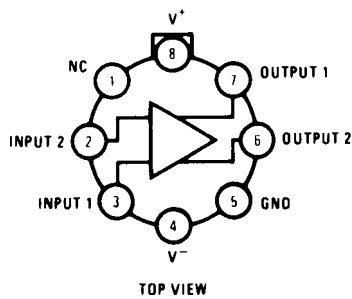

00570704

Order Number LM160H/883 (Note 1)
See NS Package Number H08C

Dual-In-Line Package

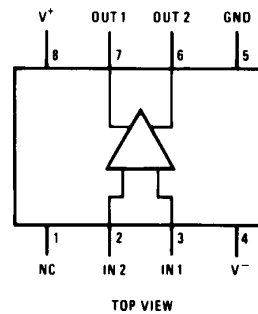

00570705

Order Number LM360M, LM360MX or LM360N
See NS Package Number M08A or N08E

Note 1: Also available in SMD# 5962-8767401

Absolute Maximum Ratings (Notes 6, 8)

If Military/Aerospace specified devices are required, please contact the National Semiconductor Sales Office/Distributors for availability and specifications.

Positive Supply Voltage	+8V
Negative Supply Voltage	-8V
Peak Output Current	20 mA
Differential Input Voltage	±5V
Input Voltage	$V^+ \geq V_{IN} \geq V^-$
ESD Tolerance (Note 9)	1600V
Operating Temperature Range	
LM160	-55°C to +125°C
LM360	0°C to +70°C

Storage Temperature Range	-65°C to +150°C
Lead Temperature	
(Soldering, 10 sec.)	260°C
Soldering Information	
Dual-In-Line Package	
Soldering (10 seconds)	260°C
Small Outline Package	
Vapor Phase (60 seconds)	215°C
Infrared (15 seconds)	220°C
See AN-450 "Surface Mounting Methods and Their Effect on Product Reliability" for other methods of soldering surface mount devices.	

Electrical Characteristics(T_{MIN} ≤ T_A ≤ T_{MAX})

Parameter	Conditions	Min	Typ	Max	Units
Operating Conditions					
Supply Voltage V _{CC} ⁺		4.5	5	6.5	V
Supply Voltage V _{CC} ⁻		-4.5	-5	-6.5	V
Input Offset Voltage	R _S ≤ 200Ω		2	5	mV
Input Offset Current			0.5	3	μA
Input Bias Current			5	20	μA
Output Resistance (Either Output)	V _{OUT} = V _{OH}		100		Ω
Response Time					
	T _A = 25°C, V _S = ±5V (Notes 2, 7)		13	25	ns
	T _A = 25°C, V _S = ±5V (Notes 3, 7)		12	20	ns
	T _A = 25°C, V _S = ±5V (Notes 4, 7)		14		ns
Response Time Difference between Outputs					
(t _{pd} of +V _{IN1}) - (t _{pd} of -V _{IN2})	T _A = 25°C (Notes 2, 7)		2		ns
(t _{pd} of +V _{IN2}) - (t _{pd} of -V _{IN1})	T _A = 25°C (Notes 2, 7)		2		ns
(t _{pd} of +V _{IN1}) - (t _{pd} of +V _{IN2})	T _A = 25°C (Notes 2, 7)		2		ns
(t _{pd} of -V _{IN1}) - (t _{pd} of -V _{IN2})	T _A = 25°C (Notes 2, 7)		2		ns
Input Resistance	f = 1 MHz		17		kΩ
Input Capacitance	f = 1 MHz		3		pF
Average Temperature Coefficient of Input Offset Voltage	R _S = 50Ω		8		μV/°C
Average Temperature Coefficient of Input Offset Current			7		nA/°C
Common Mode Input Voltage Range	V _S = ±6.5V	±4	±4.5		V
Differential Input Voltage Range		±5			V
Output High Voltage (Either Output)	I _{OUT} = -320 μA, V _S = ±4.5V	2.4	3		V
Output Low Voltage (Either Output)	I _{SINK} = 6.4 mA		0.25	0.4	V
Positive Supply Current	V _S = ±6.5V		18	32	mA
Negative Supply Current	V _S = ±6.5V		-9	-16	mA

Note 2: Response time measured from the 50% point of a 30 mVp-p 10 MHz sinusoidal input to the 50% point of the output.

Note 3: Response time measured from the 50% point of a 2 Vp-p 10 MHz sinusoidal input to the 50% point of the output.

Electrical Characteristics (Continued)

Note 4: Response time measured from the start of a 100 mV input step with 5 mV overdrive to the time when the output crosses the logic threshold.

Note 5: Typical thermal impedances are as follows:

Cavity DIP (J):	θ_{jA}	135°C/W	Header (H)	θ_{jA}	165°C/W	(Still Air)
Molded DIP (N):	θ_{jA}	130°C/W			67°C/W	(400 LF/min Air Flow)
				θ_{jC}	25°C/W	

Note 6: The device may be damaged if used beyond the maximum ratings.

Note 7: Measurements are made in AC Test Circuit, Fanout = 1

Note 8: Refer to RETS 160X for LM160H, LM160J-14 and LM160J military specifications.

Note 9: Human body model, 1.5 k Ω in series with 100 pF.

Typical Performance Characteristics

Offset Voltage

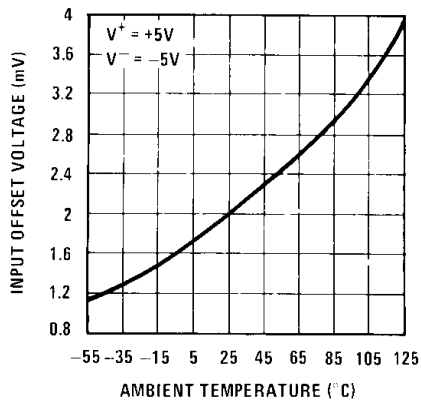

00570708

Input Current vs Ambient Temperature

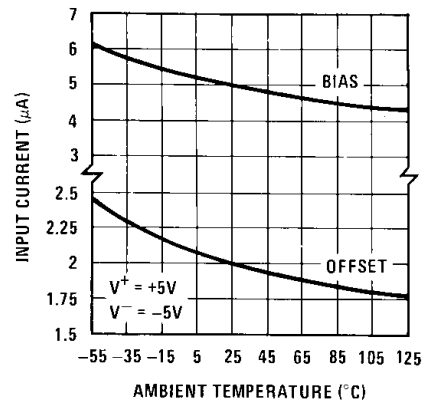

00570709

Input Characteristics

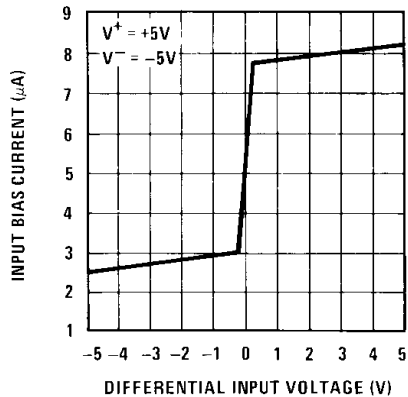

00570710

Supply Current vs Ambient Temperature

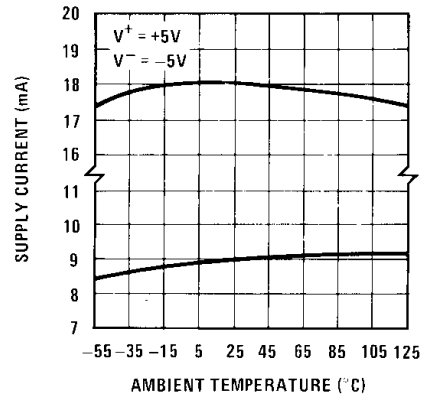

00570711

Typical Performance Characteristics (Continued)

Propagation Delay vs Ambient Temperature

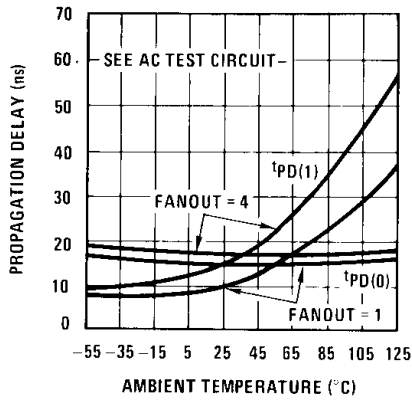

00570712

Delay of Output 1 With Respect to Output 2 vs Ambient Temperature

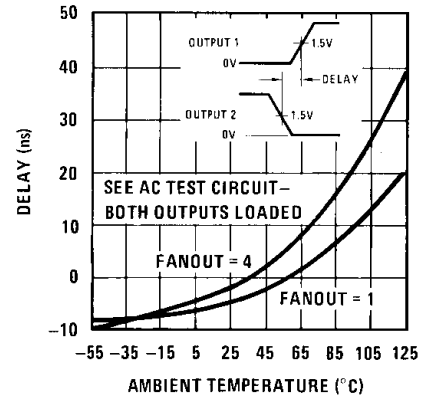

00570713

Common-Mode Pulse Response

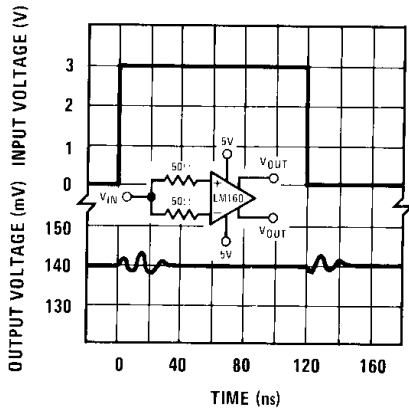

00570714

AC Test Circuit

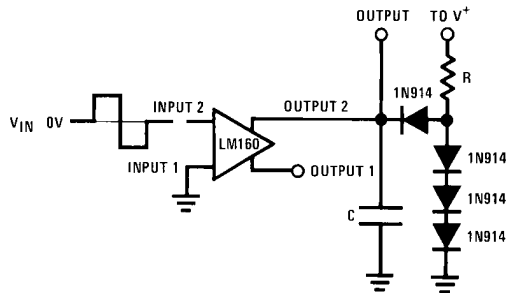

00570703

$V_{IN} = \pm 50 \text{ mV}$ FANOUT=1 FANOUT=4
 $V^+ = +5\text{V}$ $R = 2.4\text{k}$ $R = 630\Omega$
 $V^- = -5\text{V}$ $C = 15 \text{ pF}$ $C = 30 \text{ pF}$

Schematic Diagram

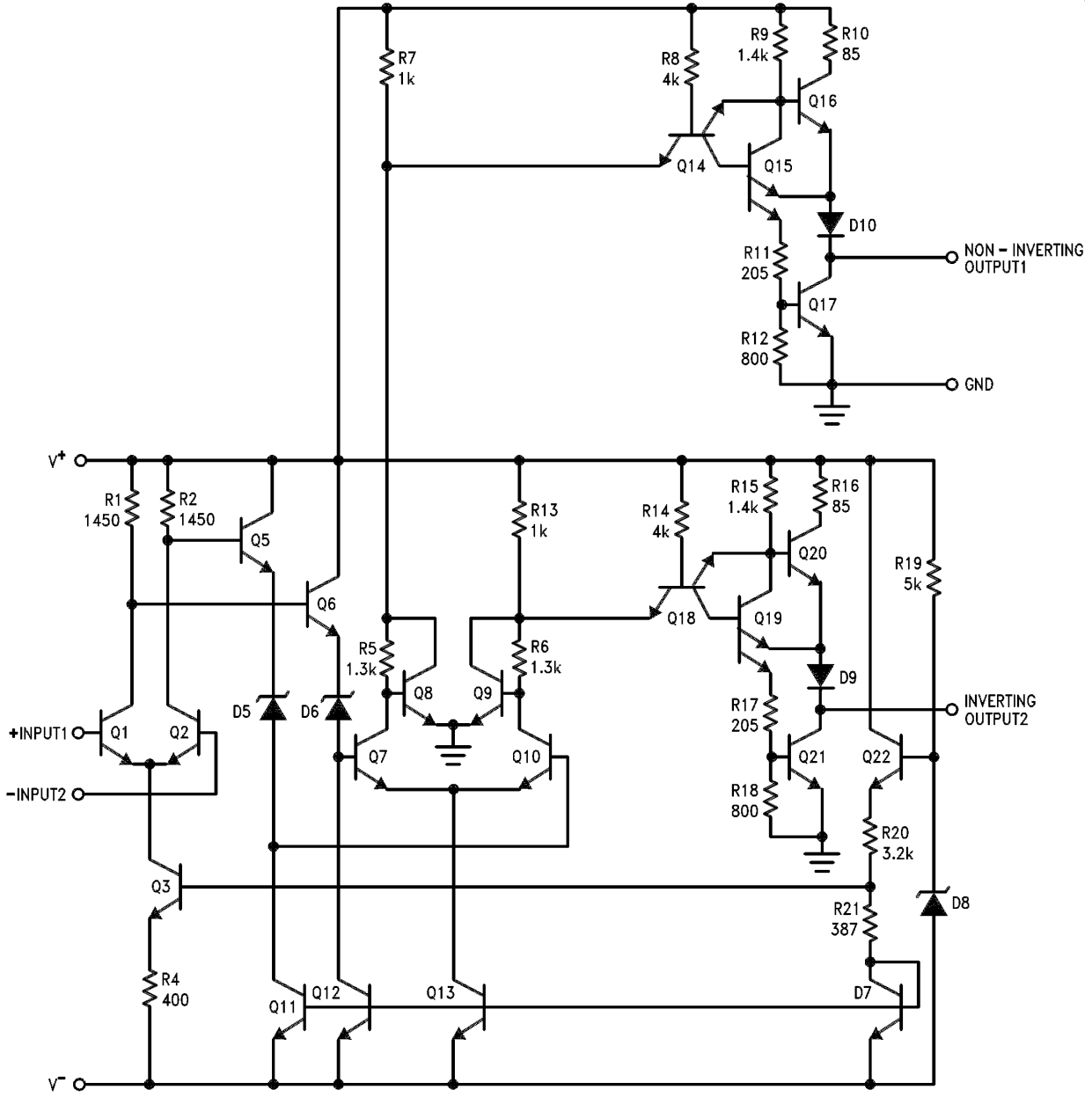

00570701

Physical Dimensions inches (millimeters)

unless otherwise noted

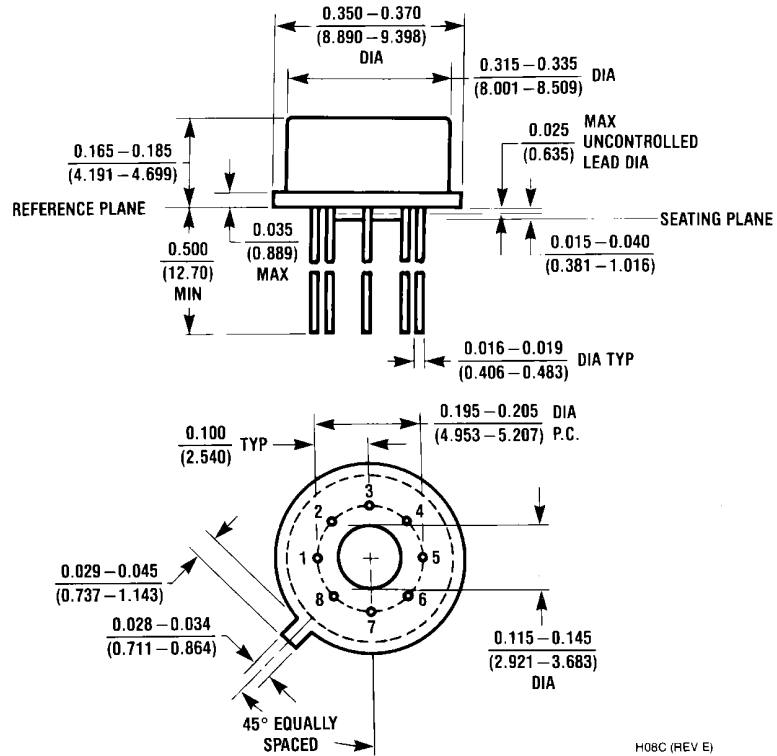

Metal Can Package (H)
Order Number LM160H/883
NS Package Number H08C

H08C (REV E)

Physical Dimensions inches (millimeters) unless otherwise noted (Continued)

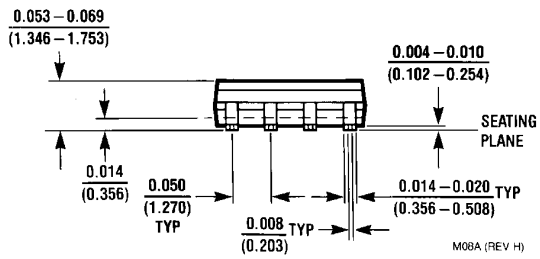
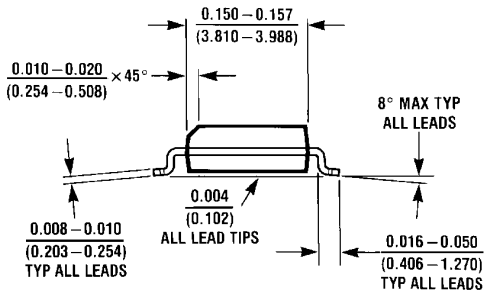
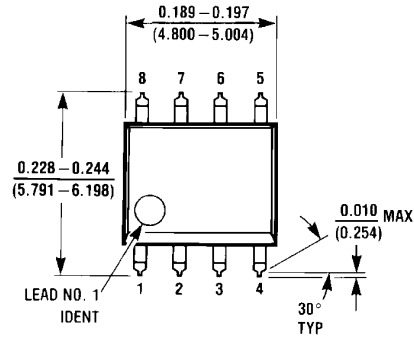

Molded Dual-In-Line Package (M)
Order Number LM360M or LM360MX
NS Package Number M08A

Physical Dimensions inches (millimeters) unless otherwise noted (Continued)

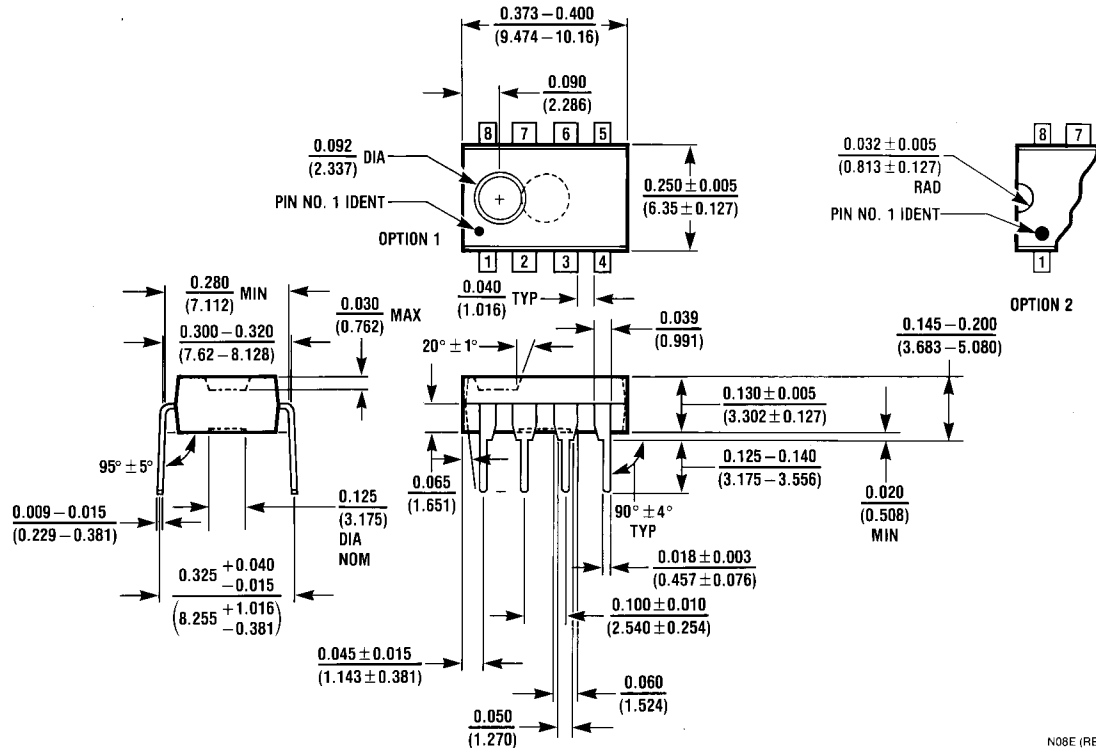

Molded Dual-In-Line Package (N)
Order Number LM360N
NS Package Number N08E

N08E (REV F)

National does not assume any responsibility for use of any circuitry described, no circuit patent licenses are implied and National reserves the right at any time without notice to change said circuitry and specifications.

For the most current product information visit us at www.national.com.

LIFE SUPPORT POLICY

NATIONAL'S PRODUCTS ARE NOT AUTHORIZED FOR USE AS CRITICAL COMPONENTS IN LIFE SUPPORT DEVICES OR SYSTEMS WITHOUT THE EXPRESS WRITTEN APPROVAL OF THE PRESIDENT AND GENERAL COUNSEL OF NATIONAL SEMICONDUCTOR CORPORATION. As used herein:

1. Life support devices or systems are devices or systems which, (a) are intended for surgical implant into the body, or (b) support or sustain life, and whose failure to perform when properly used in accordance with instructions for use provided in the labeling, can be reasonably expected to result in a significant injury to the user.
2. A critical component is any component of a life support device or system whose failure to perform can be reasonably expected to cause the failure of the life support device or system, or to affect its safety or effectiveness.

BANNED SUBSTANCE COMPLIANCE

National Semiconductor certifies that the products and packing materials meet the provisions of the Customer Products Stewardship Specification (CSP-9-111C2) and the Banned Substances and Materials of Interest Specification (CSP-9-111S2) and contain no "Banned Substances" as defined in CSP-9-111S2.

 **National Semiconductor**
Americas Customer Support Center
 Email: new.feedback@nsc.com
 Tel: 1-800-272-9959

National Semiconductor
Europe Customer Support Center
 Fax: +49 (0) 180-530 85 86
 Email: europe.support@nsc.com
 Deutsch Tel: +49 (0) 69 9508 6208
 English Tel: +44 (0) 870 24 0 2171
 Français Tel: +33 (0) 1 41 91 8790

National Semiconductor
Asia Pacific Customer Support Center
 Email: ap.support@nsc.com

National Semiconductor
Japan Customer Support Center
 Fax: 81-3-5639-7507
 Email: jpn.feedback@nsc.com
 Tel: 81-3-5639-7560