

AZ DISPLAYS

SPECIFICATIONS FOR HDMI BOARD

CUSTOMER APPROVAL			
※ PART NO.: <u>ZEDH 40PIN B SERIES HDMI BOARD</u>			
APPROVAL		COMPANY CHOP	
CUSTOMER COMMENTS			

AZ DISPLAYS ENGINEERING APPROVAL		
DESIGNED BY	CHECKED BY	APPROVED BY

A-----	Over View-----	page 4
B-----	Features-----	page 4
C-----	Application diagram-----	page 4
D-----	Power Consumption-----	page 5
E-----	Power Input-----	page 5
F-----	Outline Drawing-----	page 6
G-----	Connector Interface-----	page 8
H-----	Connector Define-----	page 10
I-----	P/N Description-----	page 12

A. Overview:

ZEDH 40pin B series HDMI board is a LCD control board designed for digital LCD modules.

It uses a highly integrated single chip IC and fewer electronic components, so It has stable working performance and good display effect.

B. Features:

- Single power supply: +5V.
- Working Temperature: 0°C~+ 65 °C.
- Supports panel resolution up to Full-HD(1920*1080).
- Supports both internal Backlight drive circuit and external Backlight drive Board
- Supports 1 channel HDMI input , 1 channel VGA input and 1 channel CVBS input with L/R Audio input.
- Supports 1 channel USB input,needs a remote to control this function.
- Supports 2 Speaker with 2 watts of power .
- Supports key board and remote.
- Supports customized LOGO.

C. Application diagram:

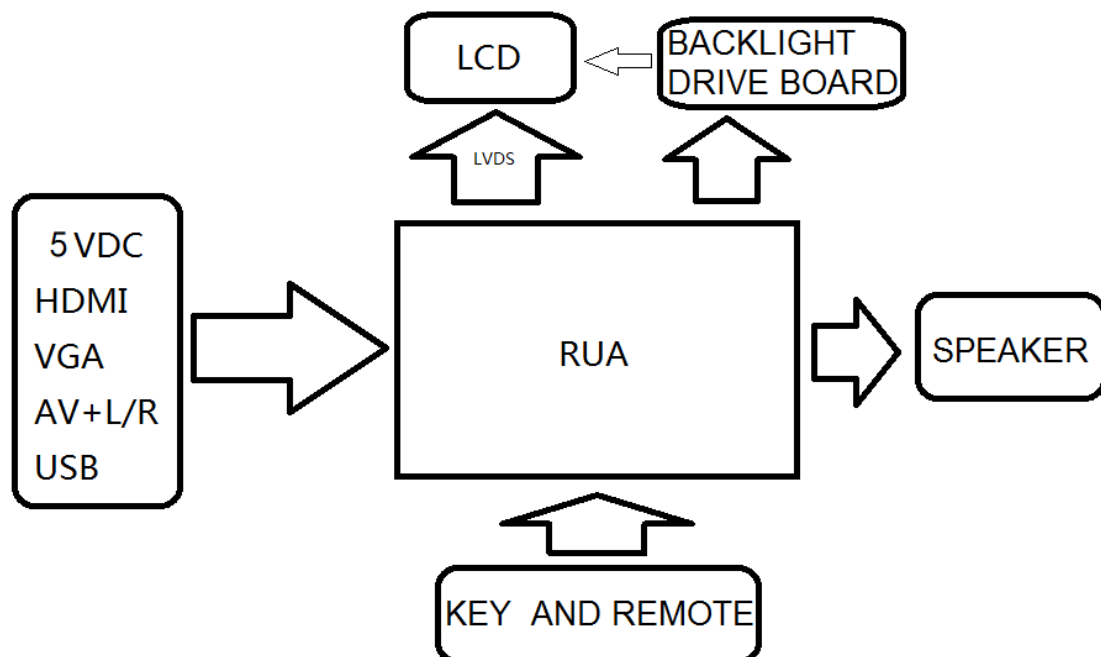

D. Power Consumption

Condition	Current Consumption			Unit
	Min	Typ	Max	
Vin = 5V		According to different panel		mA

E. Outline Drawing

- **Size:** 110.6mm*70.5mm
- **Thickness:** <9mm, including PCB board.

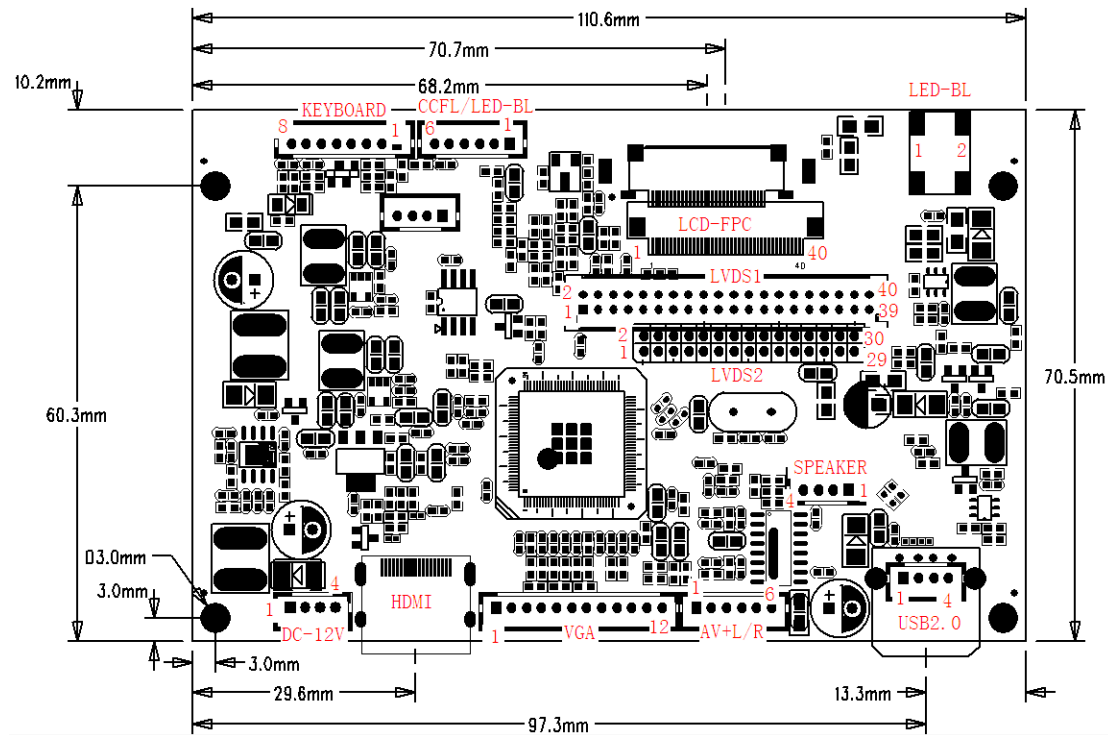

- **Product Photo:**

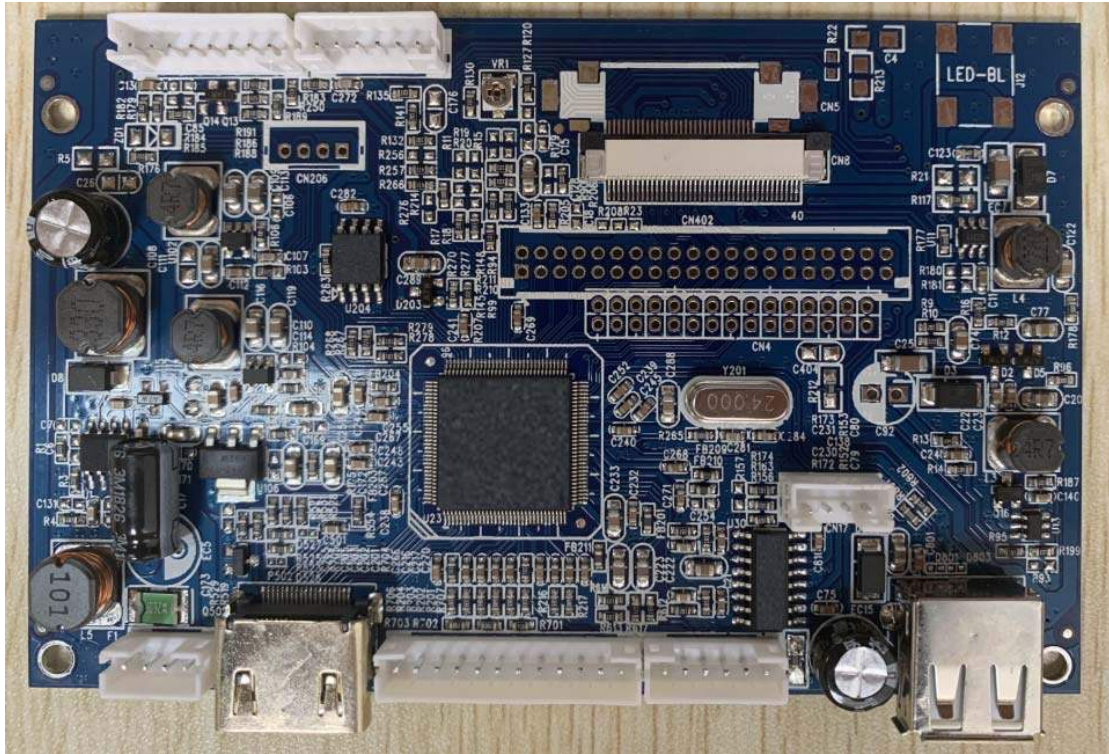

F. Connector interface description:

Connector Number	Connector Description	Pin Number	Definition
DC-5V	POWER IN	1	5V
		2	5V
		3	GND
		4	GND
VGA	VGA IN	1	RX-SCL
		2	TX-SDA
		3	GND
		4	B
		5	GND
		6	G
		7	GND
		8	R
		9	GND
		10	HS
		11	VS
		12	GND

AV+L/R	CVBS AND AUDIO IN	1	CVBS
		2	GND
		3	L CHANNEL
		4	GND
		5	R CHANNEL
		6	GND
KEY-BOARD	KEY BOARD CONNECTER	1	5V
		2	GND
		3	IR
		4	GREEN LED
		5	RED LED
		6	KEY 2
		7	KEY 1(Reserve)
		8	GND
CCFL/LED-BL	BACKLIGHT CONNECTER	1	12V
		2	12V
		3	GND
		4	PWM
		5	ON/OFF
		6	GND
SPEAKER	SPEAKER CONNECTER	1	L-
		2	L+
		3	R+
		4	R-
USB2.0	USB CONNECTER	1	5V
		2	D-
		3	D+
		4	GND

G. Connector Define:

- **LCD-FPC** ---pitch: 0.5mm/40pin

1	VCOM	Common Voltage
2	VDD	Power
3	VDD	Power
4	NC	Not Connect
5	RESET	Global Reset
6	STB	Standby Mode
7	GND	Ground
8	0-	Negative LVDS Data Signal
9	0+	Positive LVDS Data Signal
10	GND	Ground
11	1-	Negative LVDS Data Signal
12	1+	Positive LVDS Data Signal
13	GND	Ground
14	2-	Negative LVDS Data Signal
15	2+	Positive LVDS Data Signal
16	GND	Ground
17	CLK-	Negative LVDS Clock Signal
18	CLK+	Positive LVDS Clock Signal
19	GND	Ground
20	3-	Negative LVDS Data Signal
21	3+	Positive LVDS Data Signal
22	GND	Ground
23	NC	Not Connect
24	NC	Not Connect
25	GND	Ground
26	NC	Not Connect
27	NC	Not Connect
28	SELB	6/8bit Mode
29	AVDD	Power
30	GND	Ground
31	LED-	LED-
32	LED-	LED-
33	L/R	L/R
34	U/D	U/D
35	VGL	VGL
36	NC	Not Connect
37	NC	Not Connect
38	VGH	VGH
39	LED+	LED+
40	LED+	LED+

● **LVDS1---** pitch: 2.0mm*2*20

1	GND	21	E-2+
2	GND	22	E-2-
3	O-0+	23	CLK+
4	O-0-	24	CLK-
5	O-1+	25	E-3+
6	O-1-	26	E-3-
7	O-2+	27	NC
8	O-2-	28	NC
9	CLK+	29	GND
10	CLK-	30	GND
11	O-3+	31	GND
12	O-3-	32	GND
13	NC	33	+5V
14	NC	34	+5V
15	GND	35	+5V
16	GND	36	+5V
17	E-0+	37	+12V
18	E-0-	38	+12V
19	E-1+	39	+12V
20	E-1-	40	+12V

● **LVDS2:---** pitch: 2.0mm*2*15

1	0-	16	3+
2	0+	17	GND
3	1-	18	GND
4	1+	19	GND
5	GND	20	GND
6	GND	21	GND
7	GND	22	GND
8	GND	23	GND
9	GND	24	GND
10	GND	25	+3V3
11	2-	26	+3V3
12	2+	27	+5V
13	CLK-	28	+5V
14	CLK+	29	BL-PWM
15	3-	30	BL-EN

H. REMOTE (NEC CODE) AND KEY BOARD

- REMOTE controller (not offered as standard accessory, could be used to control the USB disk plugged to the USB port, could be used to display image/video stored in USB disk)



The all Remote keys could be defined any function you want.

- **KEY BOARD(Standard offer)**



POWER SOURCE MENU/DOWN MINUS PLUS

POWER : Power on/off.

SOURCE : Switch the input source.

MENU : OSD on/Page move.

MINUS : Minus value and save.

Manual Adjust Test Pattern when No SYNC Input at VIDEO Channel

PLUS : Plus value and save.

AUTO Loop Test Pattern when No SYNC Input at VIDEO Channel

NOTE: All Keyboard keys could be defined any function you want.

I. P/N DESCRIPTION

ZEDH0700L61

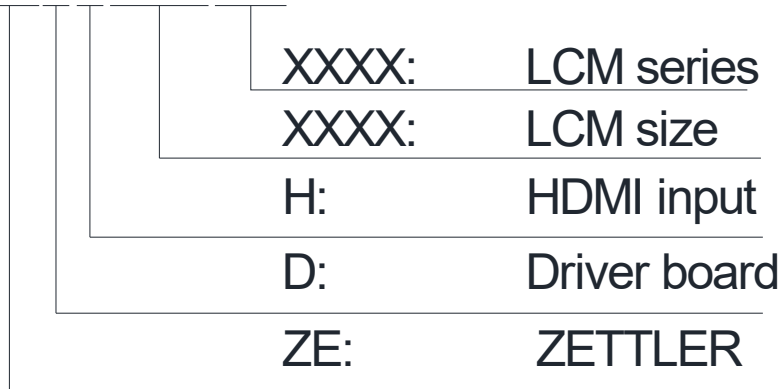

Available P/N:

ZEDH0700L61

ZEDH0700L61K (LCM will be released on December 2019)

ZEDH1010L19