

Data Sheet

1 Overview

1.1 Features

- Quad D-MOS switch driver
- Free configurable as bridge or quad-switch
- Optimized for DC motor management applications
- Low $R_{DS\ ON}$: 110 m Ω high-side switch, 100 m Ω low-side switch (typical values @ 25 °C)
- Maximum peak current: typ. 10 A @ 25 °C
- Very low quiescent current: typ. 5 μ A @ 25 °C
- Small outline, enhanced power P-DSO-package
- Full short-circuit-protection
- Operates up to 40 V
- Status flag diagnosis
- Overtemperature shut down with hysteresis
- Internal clamp diodes
- Open load detection in Off-mode
- Under-voltage detection with hysteresis
- PWM frequencies up to 1 kHz



Type	Ordering Code	Package
BTS 7741 G	Q67007-A9554	P-DSO-28-14

1.2 Description

The **BTS 7741 G** is part of the **TrilithIC** family containing three dies in one package: One double high-side switch and two low-side switches. The drains of these three vertical DMOS chips are mounted on separated lead frames. The sources are connected to individual pins, so the **BTS 7741 G** can be used in H-bridge- as well as in any other configuration. Both the double high-side and the two low-side switches of the **BTS 7741 G** are manufactured in **SMART SIPMOS**[®] technology which combines low $R_{DS\ ON}$ vertical DMOS power stages with CMOS control circuitry. The high-side switch is fully protected and contains the control and diagnosis circuitry. Also the low-side switches are fully protected, the equivalent standard product is the **BSP 77**.

In contrast to the **BTS 7740 G**, the **BTS 7741 G** offers an open load in Off-mode detection and slightly increased current limitation.

Pin Configuration
(top view)

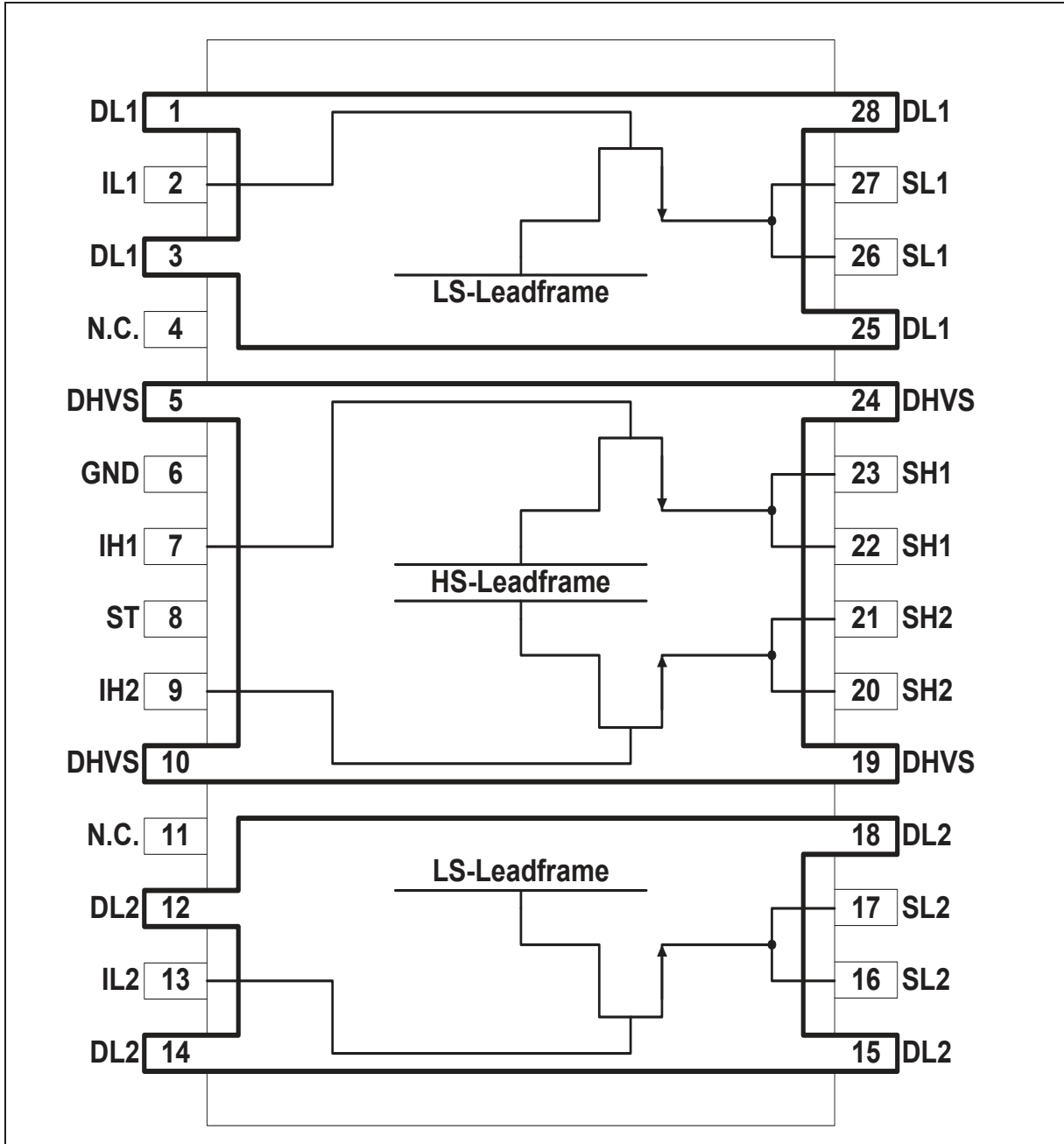

Figure 1

1.3 Pin Definitions and Functions

Pin No.	Symbol	Function
1, 3, 25, 28	DL1	Drain of low-side switch1, lead frame 1 ¹⁾
2	IL1	Analog input of low-side switch1
4	N.C.	not connected
5, 10, 19, 24	DHVS	Drain of high-side switches and power supply voltage, lead frame 2 ¹⁾
6	GND	Ground
7	IH1	Digital input of high-side switch1
8	ST	Status of high-side switches; open Drain output
9	IH2	Digital input of high-side switch2
11	N.C.	not connected
12, 14, 15, 18	DL2	Drain of low-side switch2, lead frame 3 ¹⁾
13	IL2	Analog input of low-side switch2
16,17	SL2	Source of low-side switch2
20,21	SH2	Source of high-side switch2
22,23	SH1	Source of high-side switch1
26,27	SL1	Source of low-side switch1

¹⁾ To reduce the thermal resistance these pins are direct connected via metal bridges to the lead frame.

Pins written in **bold type** need power wiring.

1.4 Functional Block Diagram

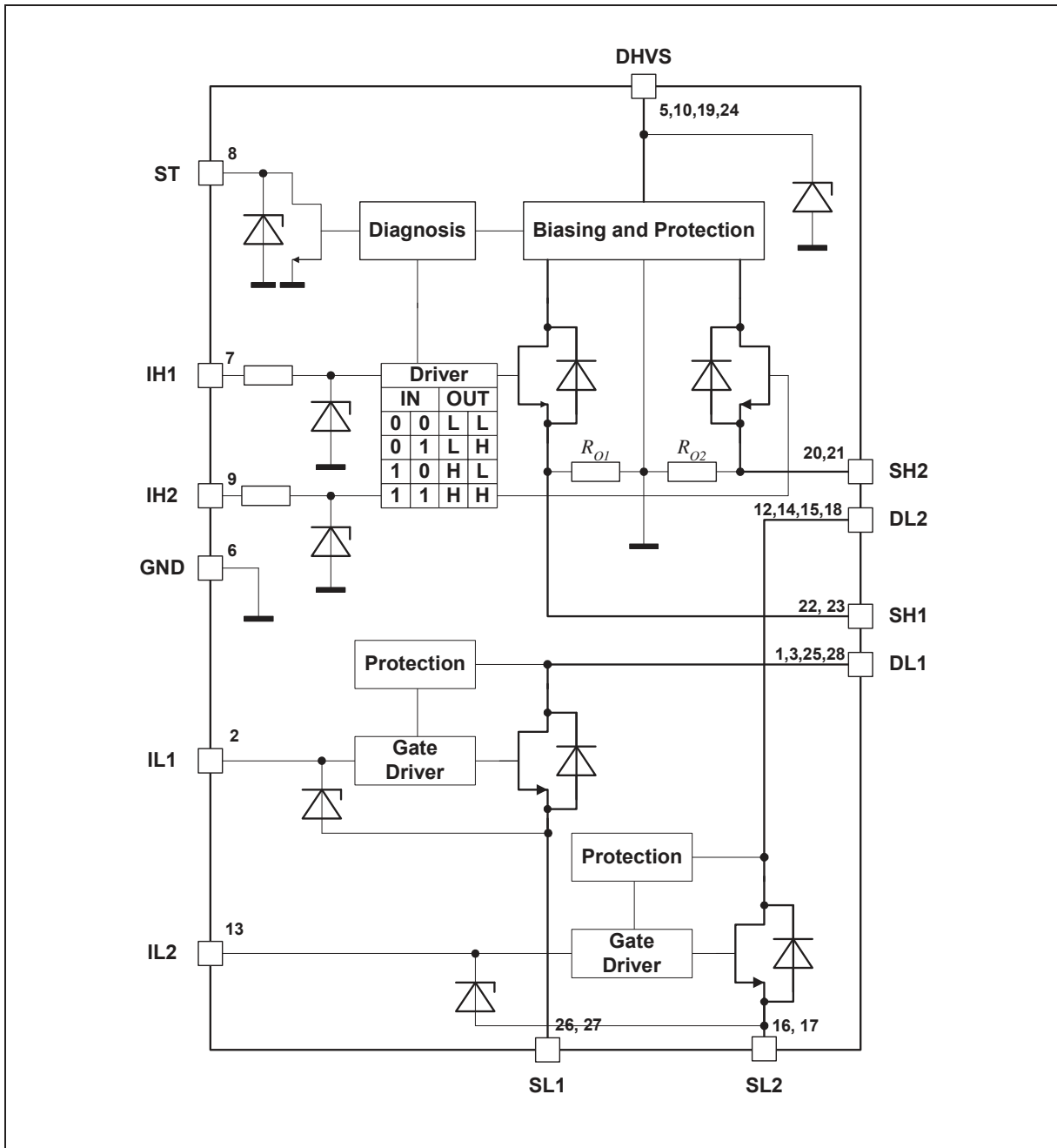

Figure 2
Block Diagram

1.5 Circuit Description

Input Circuit

The control inputs IH1,2 consist of TTL/CMOS compatible Schmitt-Triggers with hysteresis. Buffer amplifiers are driven by these stages and convert the logic signal into the necessary form for driving the power output stages. The inputs are protected by ESD clamp-diodes.

The inputs IL1 and IL2 are connected to the internal gate-driving units of the N-channel vertical power-MOS-FETs.

Output Stages

The output stages consist of an low $R_{DS\ ON}$ Power-MOS H-bridge. In H-bridge configuration, the D-MOS body diodes can be used for freewheeling when commutating inductive loads. If the high-side switches are used as single switches, positive and negative voltage spikes which occur when driving inductive loads are limited by integrated power clamp diodes.

Short Circuit Protection

The outputs are protected against

- output short circuit to ground
- output short circuit to the supply voltage, and
- overload (load short circuit).

An internal OP-Amp controls the Drain-Source-Voltage by comparing the DS-Voltage-Drop with an internal reference voltage. Above this trip point the OP-Amp reduces the output current depending on the junction temperature and the drop voltage.

In the case of overloaded high-side switches the status output is set to low.

The fully protected low-side switches have no status output.

Overtemperature Protection

The high-side and the low-side switches also incorporate an over temperature protection circuit with hysteresis which switches off the output transistors. In the case of the high-side switches, the status output is set to low.

Undervoltage-Lockout (UVLO)

When V_S reaches the switch-on voltage V_{UVON} the IC becomes active with a hysteresis. The High-Side output transistors are switched off if the supply voltage V_S drops below the switch off value V_{UVOFF} .

Open Load Detection

Open load is detected by voltage measurement in Off state. If the output voltage exceeds a specified level the error flag is set with a delay.

Status Flag

The status flag output is an open drain output with Zener-diode which requires a pull-up resistor, c.f. the application circuit on page 14. Various errors as listed in the table "Diagnosis" are detected by switching the open drain output ST to low. An open load detection is available when there is an external resistor $< R_0$ from SH1 and SH2 pin to DHVS or Vs. In order to reach low quiescent current, we recommend to disconnect this resistor when not used.

2 Truth table and Diagnosis (valid only for the High-Side-Switches)

Flag	IH1	IH2	SH1	SH2	ST	Remarks
	Inputs		Outputs			
Normal operation; identical with functional truth table	0	0	L	L	1	stand-by mode switch2 active switch1 active both switches active
	0	1	L	H	1	
	1	0	H	L	1	
	1	1	H	H	1	
Open load at high-side switch 1	0	X	Z	X	0	detected
	1	X	H	X	1	
Open load at high-side switch 2	X	0	X	Z	0	detected
	X	1	X	H	1	
Overtemperature high-side switch1	0	X	L	X	1	detected
	1	X	L	X	0	
Overtemperature high-side switch2	X	0	X	L	1	detected
	X	1	X	L	0	
Overtemperature both high-side switches	0	0	L	L	1	detected detected
	X	1	L	L	0	
	1	X	L	L	0	
Under voltage	X	X	L	L	1	not detected

Inputs:

0 = Logic LOW

1 = Logic HIGH

X = don't care

Outputs:

Z = Output in tristate condition

L = Output in sink condition

H = Output in source condition

X = Voltage level undefined

Status:

1 = No error

0 = Error

3 Electrical Characteristics

3.1 Absolute Maximum Ratings

$$-40\text{ °C} < T_j < 150\text{ °C}$$

Parameter	Symbol	Limit Values		Unit	Remarks
		min.	max.		

High-Side-Switches (Pins DHVS, IH1,2 and SH1,2)

Supply voltage	V_S	- 0.3	42	V	-
Supply voltage for full short circuit protection	$V_{S(SCP)}$		28	V	
HS-drain current*	I_S	- 7	**	A	$T_A = 25\text{ °C}; t_P < 100\text{ ms}$
HS-input current	I_{IH}	- 5	5	mA	Pin IH1 and IH2
HS-input voltage	V_{IH}	- 10	16	V	Pin IH1 and IH2

Note: * single pulse ** internally limited

Status Output ST

Status pull up voltage	V_{ST}	- 0.3	5.4	V	
Status Output current	I_{ST}	- 5	5	mA	Pin ST

Low-Side-Switches (Pins DL1,2, IL1,2 and SL1,2)

Drain-Source-Clamp voltage	V_{DSL}	42	-	V	$V_{IL} = 0\text{ V}; I_D \leq 1\text{ mA}$
Supply voltage for short circuit protection	$V_{DSL(SCP)}$		30	V	$V_{IL} = 5\text{ V}$
			20	V	$V_{IL} = 10\text{ V}$
LS-drain current*	I_{DL}	- 7	**	A	$T_A = 25\text{ °C}; t_P < 100\text{ ms}$
LS-input voltage	V_{IL}	- 0.3	10	V	-

Note: * single pulse ** internally limited

Temperatures

Junction temperature	T_j	- 40	150	°C	-
Storage temperature	T_{stg}	- 55	150	°C	-

3.1 Absolute Maximum Ratings (cont'd)

$$-40\text{ °C} < T_j < 150\text{ °C}$$

Parameter	Symbol	Limit Values		Unit	Remarks
		min.	max.		

Thermal Resistances (one HS-LS-Path active)

LS-junction case	R_{thjCL}	–	20	K/W	measured to pin 3 or 12
HS-junction case	R_{thjCH}	–	20	K/W	measured to pin 19
Junction ambient $R_{thja} = T_{j(HS)}/(P_{(HS)}+P_{(LS)})$	R_{thja}	–	60	K/W	device soldered to reference PCB with 6 cm ² cooling area

ESD Protection (Human Body Model acc. MIL STD 883D, method 3015.7 and EOS/ESD assn. standard S5.1 - 1993)

Input LS-Switch	V_{ESD}	–	2	kV	
Input HS-Switch	V_{ESD}	–	1	kV	
Status HS-Switch	V_{ESD}	–	2	kV	
Output LS and HS-Switch	V_{ESD}	–	8	kV	all other pins connected to Ground

Note: Maximum ratings are absolute ratings; exceeding any one of these values may cause irreversible damage to the integrated circuit.

3.2 Operating Range

$$-40\text{ °C} < T_j < 150\text{ °C}$$

Parameter	Symbol	Limit Values		Unit	Remarks
		min.	max.		
Supply voltage	V_S	V_{UVOFF}	42	V	After V_S rising above V_{UVON}
Input voltages	V_{IH}	– 0.3	15	V	–
Input voltages	V_{IL}	– 0.3	10	V	–
Output current	I_{ST}	0	2	mA	–
Junction temperature	T_j	– 40	150	°C	–

Note: In the operating range the functions given in the circuit description are fulfilled.

3.3 Electrical Characteristics

$I_{SH1} = I_{SH2} = I_{SL1} = I_{SL2} = 0 \text{ A}$; $-40 \text{ }^\circ\text{C} < T_j < 150 \text{ }^\circ\text{C}$; $8 \text{ V} < V_S < 18 \text{ V}$
 unless otherwise specified

Parameter	Symbol	Limit Values			Unit	Test Condition
		min.	typ.	max.		

Current Consumption HS-switch

Quiescent current	I_S	–	5	8	μA	$I_{H1} = I_{H2} = 0 \text{ V}$ $T_j = 25 \text{ }^\circ\text{C}$
		–	–	12	μA	$I_{H1} = I_{H2} = 0 \text{ V}$
Supply current	I_S	–	1.5	3	mA	I_{H1} or $I_{H2} = 5 \text{ V}$ $V_S = 12 \text{ V}$
		–	3	6	mA	I_{H1} and $I_{H2} = 5 \text{ V}$ $V_S = 12 \text{ V}$
Leakage current of high-side switch	I_{SHLK}	–	–	6	μA	$V_{IH} = V_{SH} = 0 \text{ V}$
Leakage current through logic GND in free wheeling condition	$I_{LKCL} = I_{FH} + I_{SH}$	–	–	10	mA	$I_{FH} = 3 \text{ A}$

Current Consumption LS-switch

Input current	I_{IL}	–	8	30	μA	$V_{IL} = 5 \text{ V}$; normal operation
		–	160	300	μA	$V_{IL} = 5 \text{ V}$; failure mode
Leakage current of low-side switch	I_{DLK}	–	2	10	μA	$V_{IL} = 0 \text{ V}$

Under Voltage Lockout (UVLO) HS-switch

Switch-ON voltage	V_{UVON}	–	–	4.8	V	V_S increasing
Switch-OFF voltage	V_{UVOFF}	1.8	–	3.5	V	V_S decreasing
Switch ON/OFF hysteresis	V_{UVHY}	–	1	–	V	$V_{UVON} - V_{UVOFF}$

3.3 Electrical Characteristics (cont'd)

$I_{SH1} = I_{SH2} = I_{SL1} = I_{SL2} = 0 \text{ A}$; $-40 \text{ }^\circ\text{C} < T_j < 150 \text{ }^\circ\text{C}$; $8 \text{ V} < V_s < 18 \text{ V}$
 unless otherwise specified

Parameter	Symbol	Limit Values			Unit	Test Condition
		min.	typ.	max.		

Output stages

Inverse diode of high-side switch; Forward-voltage	V_{FH}	–	0.8	1.2	V	$I_{FH} = 3 \text{ A}$
Inverse diode of low-side switch; Forward-voltage	V_{FL}	–	0.8	1.2	V	$I_{FL} = 3 \text{ A}$
Static drain-source on-resistance of high-side switch	$R_{DS\ ON\ H}$	–	110	140	m Ω	$I_{SH} = 1 \text{ A}$ $T_j = 25 \text{ }^\circ\text{C}$
Static drain-source on-resistance of low-side switch	$R_{DS\ ON\ L}$	–	100	120	m Ω	$I_{SL} = 1 \text{ A}$; $V_{GL} = 5 \text{ V}$ $T_j = 25 \text{ }^\circ\text{C}$
Static path on-resistance	$R_{DS\ ON}$	–	–	500	m Ω	$R_{DS\ ON\ H} + R_{DS\ ON\ L}$ $I_{SH} = 1 \text{ A}$;

Short Circuit of high-side switch to GND

Initial peak SC current	$I_{SCP\ H}$	9	11	14	A	$T_j = -40 \text{ }^\circ\text{C}$
		8	10	13	A	$T_j = +25 \text{ }^\circ\text{C}$
		6	8	10	A	$T_j = +150 \text{ }^\circ\text{C}$

Short Circuit of high-side switch to V_s

Output pull-down-resistor	R_O	12	22	50	k Ω	$V_{DSL} = 3 \text{ V}$
---------------------------	-------	----	----	----	------------	-------------------------

Short Circuit of low-side switch to V_s

Initial peak SC current	$I_{SCP\ L}$	14	17	22	A	$T_j = -40 \text{ }^\circ\text{C}$
		12	15	20	A	$T_j = 25 \text{ }^\circ\text{C}$
		8.5	10	15	A	$T_j = 150 \text{ }^\circ\text{C}$

Note: Integrated protection functions are designed to prevent IC destruction under fault conditions. Protection functions are not designed for continuous or repetitive operation.

3.3 Electrical Characteristics (cont'd)

$I_{SH1} = I_{SH2} = I_{SL1} = I_{SL2} = 0 \text{ A}$; $-40 \text{ }^\circ\text{C} < T_j < 150 \text{ }^\circ\text{C}$; $8 \text{ V} < V_S < 18 \text{ V}$
 unless otherwise specified

Parameter	Symbol	Limit Values			Unit	Test Condition
		min.	typ.	max.		

Thermal Shutdown

Thermal shutdown junction temperature	T_{jSD}	155	180	190	$^\circ\text{C}$	–
Thermal switch-on junction temperature	T_{jSO}	150	170	180	$^\circ\text{C}$	–
Temperature hysteresis	ΔT	–	10	–	$^\circ\text{C}$	$\Delta T = T_{jSD} - T_{jSO}$

Status Flag Output ST of high-side switch

Low output voltage	V_{STL}	–	0.2	0.6	V	$I_{ST} = 1.6 \text{ mA}$
Leakage current	I_{STLK}	–	–	10	μA	$V_{ST} = 5 \text{ V}$
Zener-limit-voltage	V_{STZ}	5.4	–	–	V	$I_{ST} = 1.6 \text{ mA}$

Open load detection in Off condition

Open load detection voltage	$V_{OUT(OL)}$	1.8	2.8	4	V	
Status change after neg. input slope with OL	$t_{d(OL)}$			500	μs	$V_S = 12 \text{ V}$

Switching times of high-side switch

Turn-ON-time; to 90% V_{SH}	t_{ON}	–	85	180	μs	$R_{Load} = 12 \text{ } \Omega$ $V_S = 12 \text{ V}$
Turn-OFF-time; to 10% V_{SH}	t_{OFF}	–	80	180	μs	$R_{Load} = 12 \text{ } \Omega$ $V_S = 12 \text{ V}$
Slew rate on 10 to 30% V_{SH}	dV/dt_{ON}	–	–	1.2	V/ μs	$R_{Load} = 12 \text{ } \Omega$ $V_S = 12 \text{ V}$
Slew rate off 70 to 40% V_{SH}	$-dV/dt_{OFF}$	–	–	1.5	V/ μs	$R_{Load} = 12 \text{ } \Omega$ $V_S = 12 \text{ V}$

Note: switching times are not subject to production test - specified by design

3.3 Electrical Characteristics (cont'd)

$I_{SH1} = I_{SH2} = I_{SL1} = I_{SL2} = 0$ A; $-40\text{ }^{\circ}\text{C} < T_j < 150\text{ }^{\circ}\text{C}$; $8\text{ V} < V_S < 18\text{ V}$
 unless otherwise specified

Parameter	Symbol	Limit Values			Unit	Test Condition
		min.	typ.	max.		

Switching times of low-side switch

Turn ON time to 10% V_{DL} $V_{IL} = 0$ to 10 V	t_{ON}	–	50	150	μs	$R_{Load} = 10\ \Omega$ $V_S = 12\text{ V}$
Turn-OFF-time; to 90% V_{DL}	t_{OFF}	–	60	150	μs	$R_{Load} = 10\ \Omega$ $V_S = 12\text{ V}$
Slew rate on 70 to 50% V_{SH} $V_{IL} = 0$ to 10 V	$-dV/dt_{ON}$	–	1	1.5	$\text{V}/\mu\text{s}$	$R_{Load} = 4.7\ \Omega$ $V_S = 12\text{ V}$
Slew rate off 50 to 70% V_{SH} $V_{IL} = 0$ to 10 V	dV/dt_{OFF}	–	1	1.5	$\text{V}/\mu\text{s}$	$R_{Load} = 4.7\ \Omega$ $V_S = 12\text{ V}$

Note: switching times are not subject to production test - specified by design

Control Inputs of high-side switches GH 1, 2

H-input voltage	$V_{IH\ High}$	–	–	2.5	V	–
L-input voltage	$V_{IH\ Low}$	1	–	–	V	–
Input voltage hysteresis	$V_{IH\ HY}$	–	0.3	–	V	–
H-input current	$I_{IH\ High}$	15	30	60	μA	$V_{IH} = 5\text{ V}$
L-input current	$I_{IH\ Low}$	5	–	20	μA	$V_{IH} = 0.4\text{ V}$
Input series resistance	R_i	2.7	4	5.5	$\text{k}\Omega$	–
Zener limit voltage	$V_{IH\ Z}$	5.4	–	–	V	$I_{IH} = 1.6\text{ mA}$

Control Inputs GL1, 2

Gate-threshold-voltage	$V_{IL\ th}$	0.9	1.7	2.2	V	$I_{DL} = 2\text{ mA}$
------------------------	--------------	-----	-----	-----	---	------------------------

Note: The listed characteristics are ensured over the operating range of the integrated circuit. Typical characteristics specified mean values expected over the production spread. If not otherwise specified, typical characteristics apply at $T_A = 25\text{ }^{\circ}\text{C}$ and the given supply voltage.

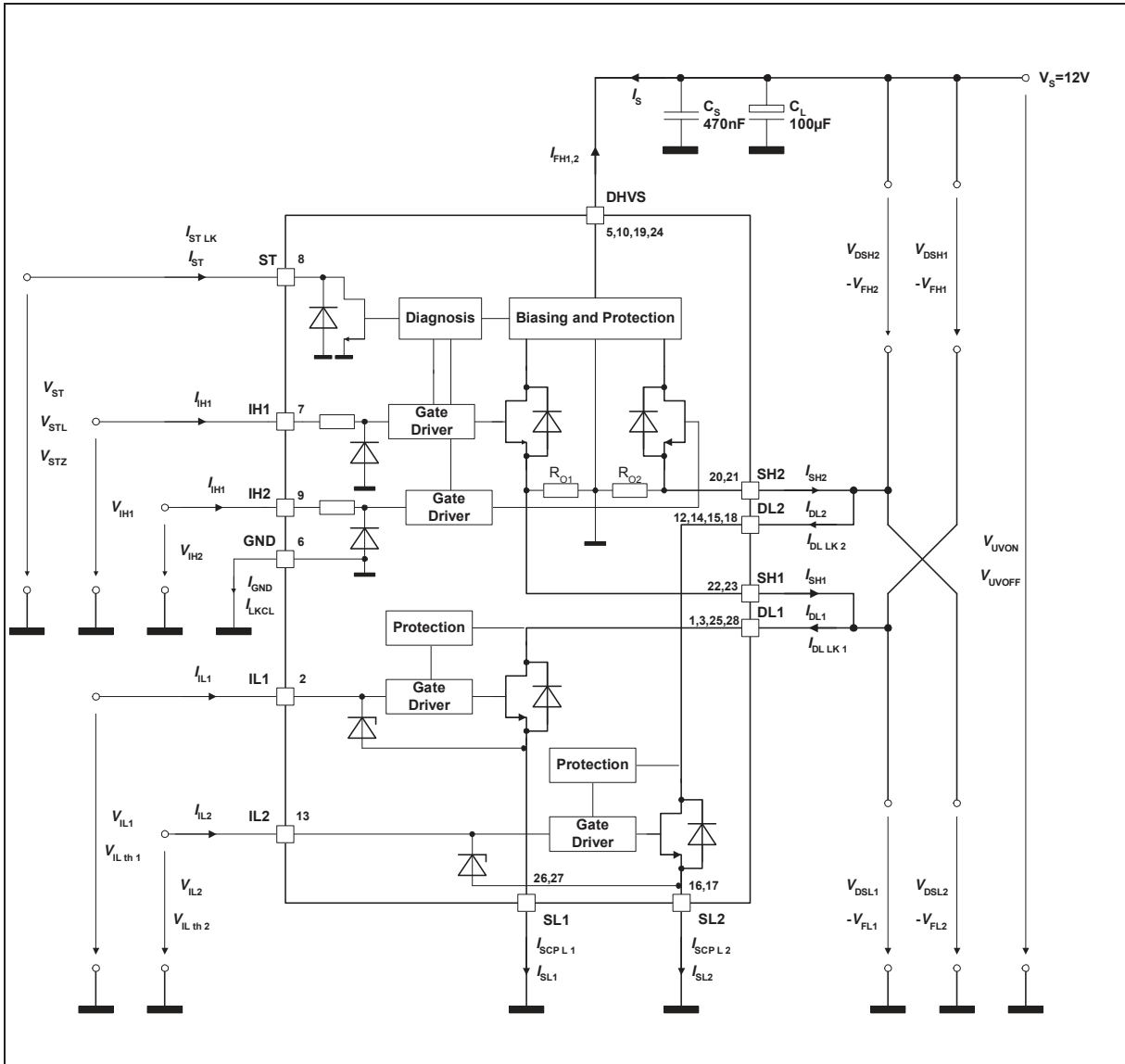

Figure 3
Test Circuit

HS-Source-Current	Named during Short Circuit	Named during Leakage-Cond.
$I_{SH1,2}$	$I_{SCP H}$	$I_{DL LK}$

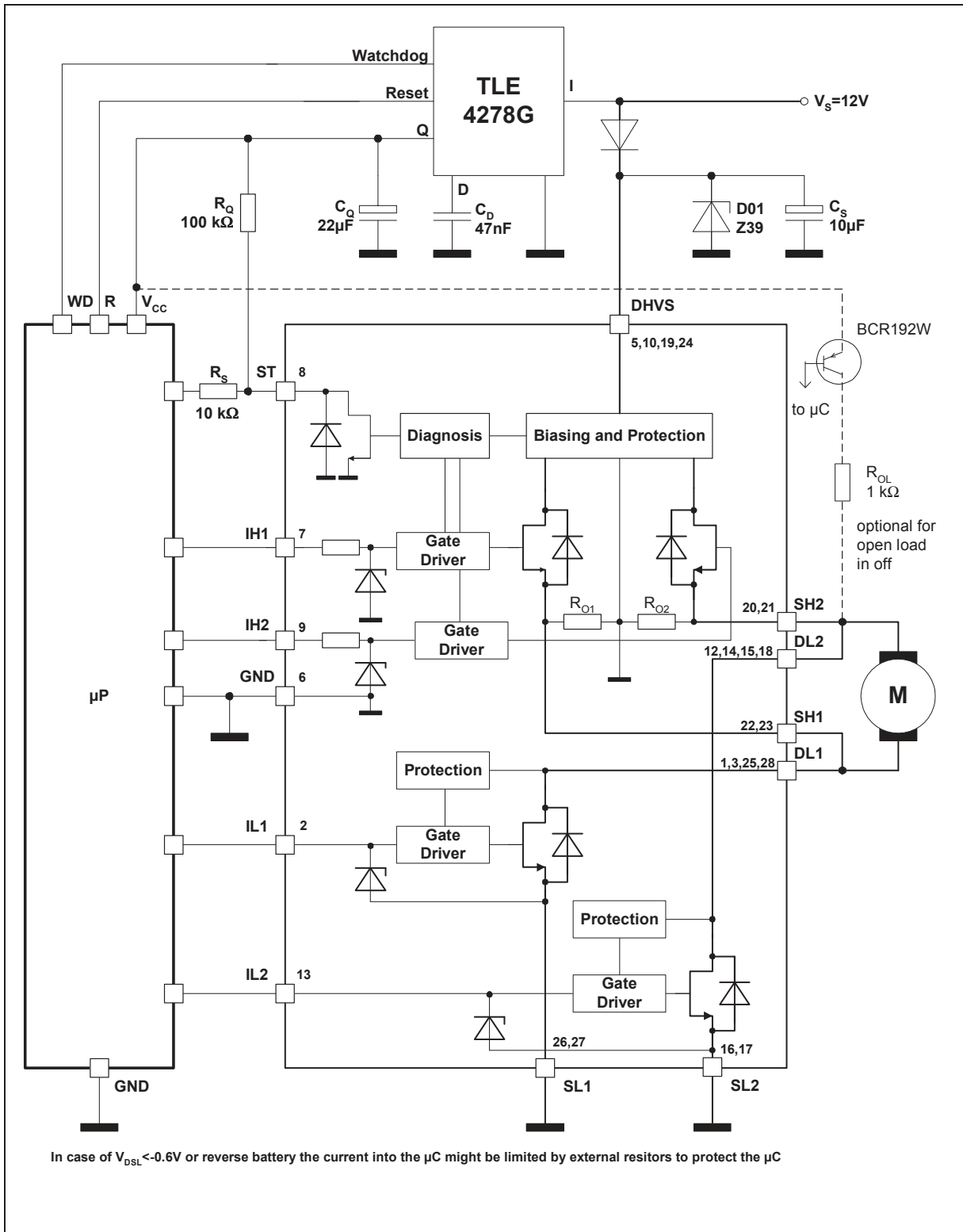
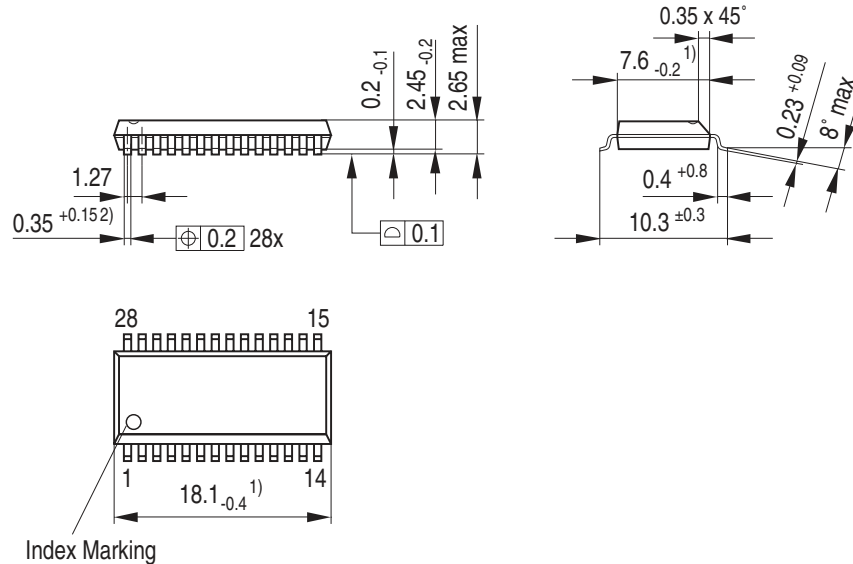

Figure 4
Application Circuit

4 Package Outlines

P-DSO-28-14
(Plastic Transistor Single Outline Package)



- 1) Does not include plastic or metal protrusions of 0.15 max per side
- 2) Does not include dambar protrusion of 0.05 max per side

GPS05123

GPS05123

Sorts of Packing

Package outlines for tubes, trays etc. are contained in our Data Book "Package Information".

SMD = Surface Mounted Device

Dimensions in mm

Edition 2003-01

**Published by Infineon Technologies AG,
St.-Martin-Strasse 53,
D-81669 München, Germany**

**© Infineon Technologies AG 3/13/03.
All Rights Reserved.**

Attention please!

The information herein is given to describe certain components and shall not be considered as a guarantee of characteristics.

Terms of delivery and rights to technical change reserved.

We hereby disclaim any and all warranties, including but not limited to warranties of non-infringement, regarding circuits, descriptions and charts stated herein.

Infineon Technologies is an approved CECC manufacturer

Information

For further information on technology, delivery terms and conditions and prices please contact your nearest Infineon Technologies Office in Germany or our Infineon Technologies Representatives worldwide (see address list).

Warnings

Due to technical requirements components may contain dangerous substances. For information on the types in question please contact your nearest Infineon Technologies Office.

Infineon Technologies Components may only be used in life-support devices or systems with the express written approval of Infineon Technologies, if a failure of such components can reasonably be expected to cause the failure of that life-support device or system, or to affect the safety or effectiveness of that device or system. Life support devices or systems are intended to be implanted in the human body, or to support and/or maintain and sustain and/or protect human life. If they fail, it is reasonable to assume that the health of the user or other persons may be endangered.