

LOC	DIST	P	ZONE	LTR	DESCRIPTION	DATE	APPD
G	14			A	REV 8 REDRAWN PER 0720-0008-93	2-2-93	18 DAP

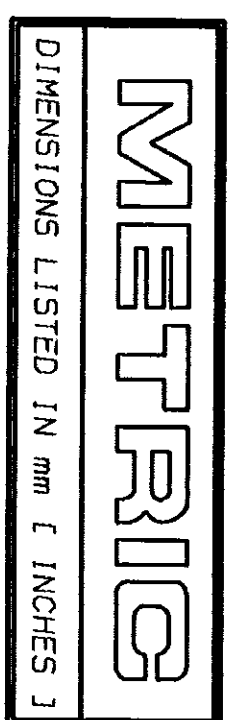

AMP WIRE RANGE 26-22 AWG STRANDED	UL E13288 Listed
LR7189 Certified	MILITARY P/N AND CLASS
NOT CERTIFIED	NOT APPLICABLE
NOT LISTED	NOT LISTED

△ STAMP AMP APPROX AS SHOWN

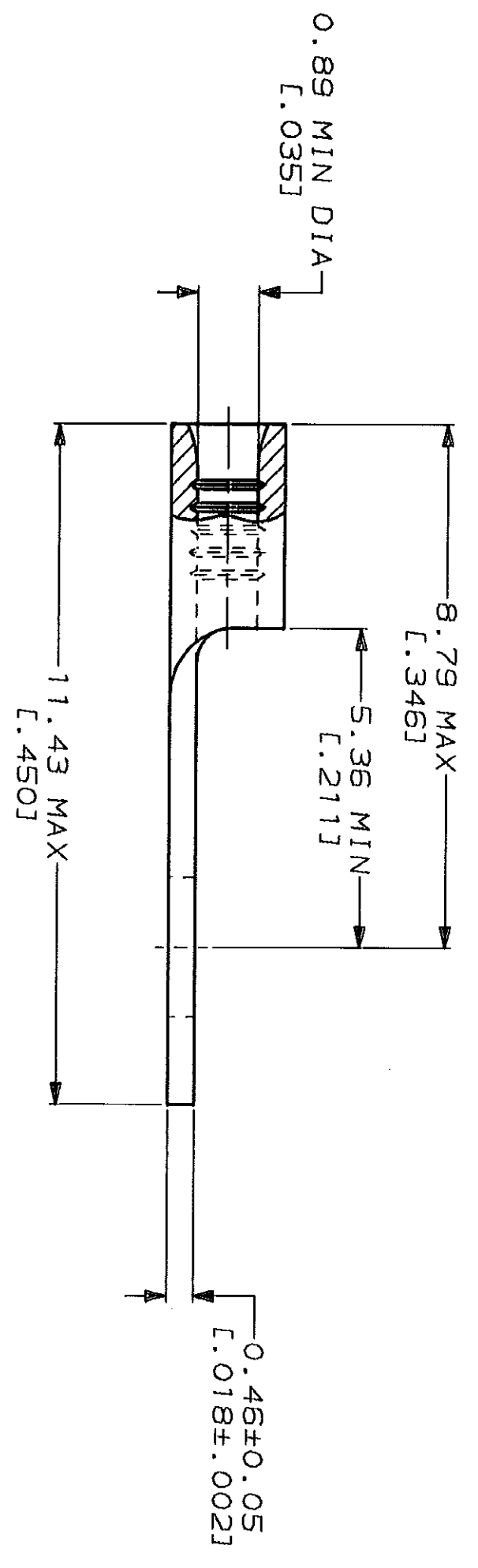
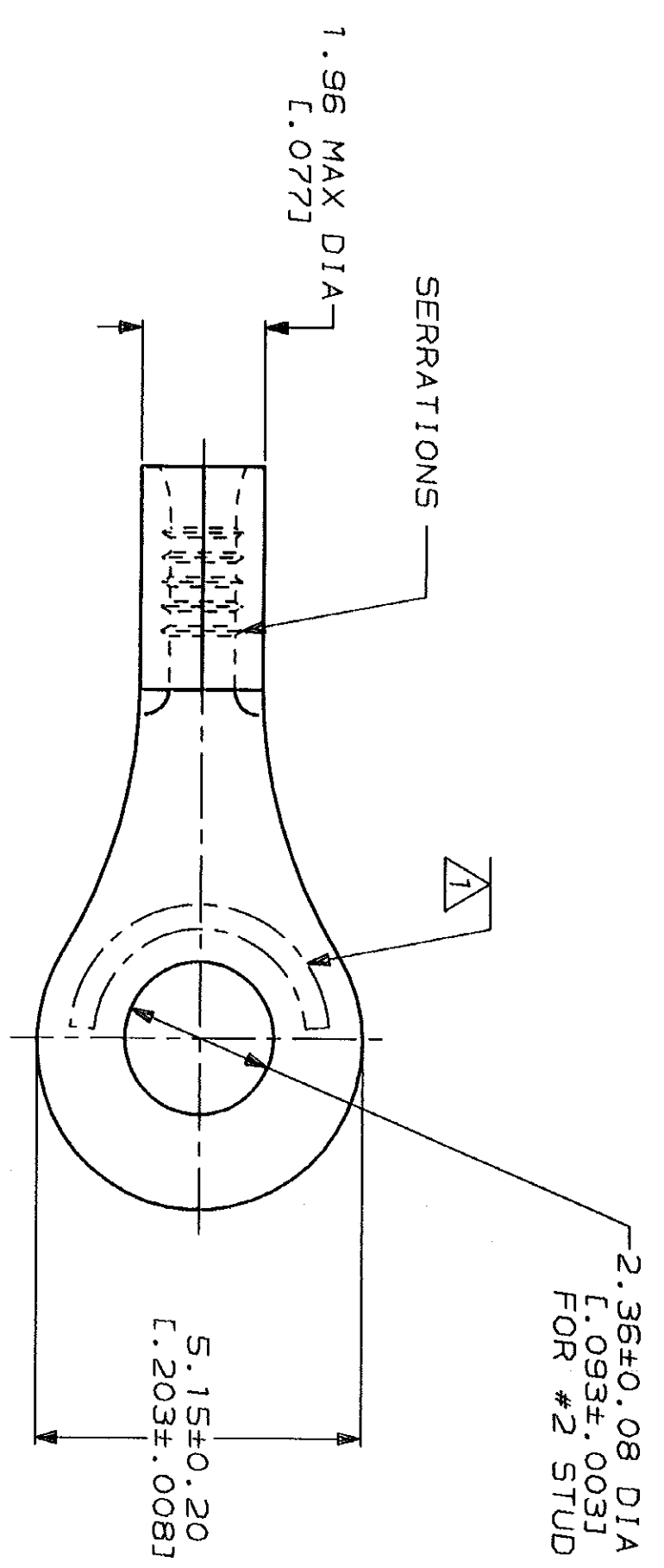

**AMP INCORPORATED
 CUSTOMER SERVICE SYSTEMS**

FOR ADDITIONAL
 PRODUCT INFORMATION OR
 COPIES OF DRAWINGS
 AND TECHNICAL DOCUMENTS
 1-800-522-6752

FOR APPLICATION
 TOOLING ASSISTANCE CENTER
 1-800-722-1111

FOR ORDER ENTRY
 1-800-526-5142

MAX RECOMMENDED OPERATING
 TEMPERATURE:
 170°C MAX

VOLTAGE RATING:
 NOT APPLICABLE

WIRE CROSS SECTIONAL AREA RANGE:
 0.1-0.41mm² [202-810] CIR MILS
 STRANDED

THIS DRAWING IS A CONTROLLED DOCUMENT FOR
 THE COMPANY. IT IS SUBJECT TO CHANGE
 AND THE COMPANY ASSUMES NO LIABILITY
 SHOULD BE CONTACTED FOR THE LATEST REVISION.

DO NOT SCALE PRINT.
 UNLESS SPECIFIED
 DIMENSIONS IN mm [INCHES]
 TOLERANCES ON:
 2 PLC DEC # -
 3 PLC DEC # -
 ANGLES # -
 MATERIAL
 COPPER PER
 ASTM B-152
 ANNEALED

FINISH
 TIN PLATE
 0.00254 [L.000100] MIN
 THK PER MIL-T-10727

DR 2-2-93 TA BRINKMAN	NAME
CHK 2-2-93 DA PATTERSON	AMP
APPD 2-2-93 DE MILLER	AMP Incorporated
APPD 2-2-93 JL MECKLEY	Harrisburg, PA 17105-3608
PRODUCT SPEC	
APPLICATION SPEC	
WEIGHT	

AMP
 AMP Incorporated
 Harrisburg, PA 17105-3608

TERMINAL, RING
 TONGUE, BUDGET

SIZE CAGE CODE DRAWING NO
 00779 33695

SCALE 10:1 SHEET 1 OF 1