

FMA SERIES

32347833
Issue C

MicroForce Sensors, Compensated/Amplified

DESCRIPTION

The FMA Series are piezoresistive-based force sensors offering a digital output for reading force over the specified full scale force span and temperature range. They are fully calibrated and temperature compensated for sensor offset, sensitivity, temperature effects, and nonlinearity using an on-board Application Specific Integrated Circuit (ASIC). Direct mechanical coupling allows for easy interface with the sensor, coupling with tubing, membrane or a plunger, providing repeatable performance and a reliable mechanical interface to the application. All products are designed and manufactured according to ISO 9001 standards. These products offer a more stable output which is directly proportional to the force applied to the mechanically-coupled sphere.

The FMA Series is available with pocket tape and reel packaging.

VALUE TO CUSTOMERS

The FMA Series are designed to meet the customer's need for a compensated, amplified force sensor which provides digital outputs, a variety of force sensing ranges, a small, cost-effective format, and enhanced durability and accuracy. The flexible design provides multiple standard configurations over a wide operating temperature range.

DIFFERENTIATION

- Multiple force ranges allow the customer to choose the force range to maximize sensitivity and improve system resolution/performance
- Smaller package allows for space constrained applications
- Robust design provides enhanced durability in applications where overforce may exist
- Enhanced accuracy includes all errors due to force non-linearity, force hysteresis, and non-repeatability
- Reduced Total Error Band enhances system performance
- Digital output enhances performance through reduced conversion requirements and the convenience of direct interface to microprocessors
- Diagnostic functions allow the user to determine if the sensor is working correctly by detecting if electrical paths are broken or shorted inside the sensor
- Selectable supply voltages provide customers with design flexibility

POTENTIAL APPLICATIONS

MEDICAL

- Infusion pumps
- Ambulatory pumps
- Enteral feeding pumps
- Kidney dialysis machines

INDUSTRIAL

- Load and compression sensing
- Touch panels
- Switch replacement
- Robotic equipment
- Weight measurement
- Force/grip measuring equipment

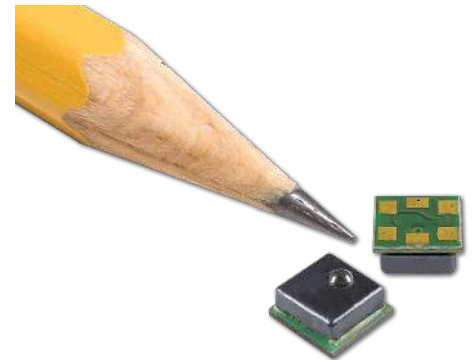

FEATURES

- Small form factor: 5 mm x 5 mm [0.20 in x 0.20 in]
- Accuracy: ± 2 %FSS typical
- SPI- or I²C-compatible digital output
- Fully calibrated and temperature compensated over a temperature range of 5°C to 50°C [41°F to 122°F]
- Available in a wide variety of standard and configurable force ranges
- Overforce: 3X force range
- Supply voltage: 3.3 Vdc typ. or 5.0 Vdc typ.
- Low power consumption: 14 mW
- Enhanced part-to-part repeatability
- Enhanced reliability
- Stable, stainless steel sphere interface
- Internal diagnostic functions available
- REACH and RoHS compliant



The FMA Series joins the FSA Series, FSG Series, FSS Series, FSS-SMT Series, TBF Series, and 1865 Series Force Sensors. To view the entire product portfolio, [click here](#).

Honeywell

MICROFORCE SENSORS, FMA SERIES

TABLE 1. ABSOLUTE MAXIMUM SPECIFICATIONS

CHARACTERISTIC	MINIMUM	TYPICAL	MAXIMUM	UNIT
Supply voltage	-0.3	—	6.0	Vdc
Voltage on any pin	-0.3	—	V _{supply} + 0.3	V
Digital clock frequency:				
SPI	50	—	800	kHz
I ² C	100	—	400	
ESD susceptibility (human body model)	8	—	—	kV
Storage temperature range	-40 [-40]	—	85 [185]	°C °[F]
Overforce limit	—	—	3X force range ¹	—

¹Repeated exposure to the overforce may cause permanent damage to the sensor.

TABLE 2. OPERATING SPECIFICATIONS

CHARACTERISTIC	MINIMUM	TYPICAL	MAXIMUM	UNIT
Supply voltage (V _{supply}) ^{1,2,3} :				
3.3 Vdc	3.0	3.3	3.6	Vdc
5.0 Vdc	4.75	5.0	5.25	
Supply current:				
3.3 Vdc	—	2.8	3.9	mA
5.0 Vdc	—	3.9	4.6	
Power input	—	20	—	mW
Operating temperature range ⁴	-40 [-40]	—	85 [185]	°C °[F]
Compensated temperature range ⁵	5 [41]	—	50 [122]	°C °[F]
Storage temperature range	-40 [-40]	—	85 [185]	°C °[F]
Startup time (power up to data ready)	—	—	3	ms
Response time	—	0.42	0.84	ms
SPI/I ² C voltage level:				
low	—	—	20	V _{supply}
high	80	—	—	
Pull up on SDA/MISO, SCL/SCLK, SS	1	—	—	kOhm
Accuracy ⁶	—	±2	—	%FSS ⁷ BFSL
Total Error Band ⁸	—	—	±8	%FSS
Output resolution	12	—	—	bits
Long term stability	—	±1.6	—	%FSS

¹Sensors are either 3.3 Vdc or 5.0 Vdc based on the catalog listing selected.

²Ratiometricity of the sensor (the ability of the device output to scale to the supply voltage) is achieved within the specified operating voltage.

³The sensor is not reverse polarity protected. Incorrect application of supply voltage or ground to the wrong pin may cause electrical failure.

⁴**Operating temperature range:** The temperature range over which the sensor will produce an output proportional to force.

⁵**Compensated temperature range:** The temperature range over which the sensor will produce an output proportional to force within the specified performance limits.

⁶**Accuracy:** The maximum deviation in output from a Best Fit Straight Line (BFSL) fitted to the output measured over the force range with single load-unload cycle at 25°C. Includes all errors due to force non linearity, force hysteresis, and non repeatability.

⁷**Full Scale Span (FSS):** The algebraic difference between the output voltage at full scale force and the output at zero force.

⁸**Total Error Band (TEB):** Combined error from calibration, accuracy and temperature effects over the compensated temperature range at 5.0 V from 20 %FSS to 80 %FSS.

MICROFORCE SENSORS, FMA SERIES

TABLE 3. ENVIRONMENTAL SPECIFICATIONS

CHARACTERISTIC	PARAMETER
Humidity	0% to 95% RH, non-condensing
Vibration	MIL-STD-202, Method 214, Condition 1F (20.71 Gms)
Shock	MIL-STD-202, Method 213, Condition A (50 G)
Life ¹	1 million full scale force cycles minimum

¹Life may vary depending on specific application in which the sensor is utilized.

TABLE 4. MATERIALS

COMPONENT	MATERIAL ¹
Covers	liquid crystal polymer
Sphere contact element	stainless steel 440C
Substrate	FR4
Adhesives	epoxy, silicone
Electronic components	silicon, glass, solder

¹Contact Honeywell customer service for detailed material information.

FIGURE 1. TRANSFER FUNCTION LIMITS

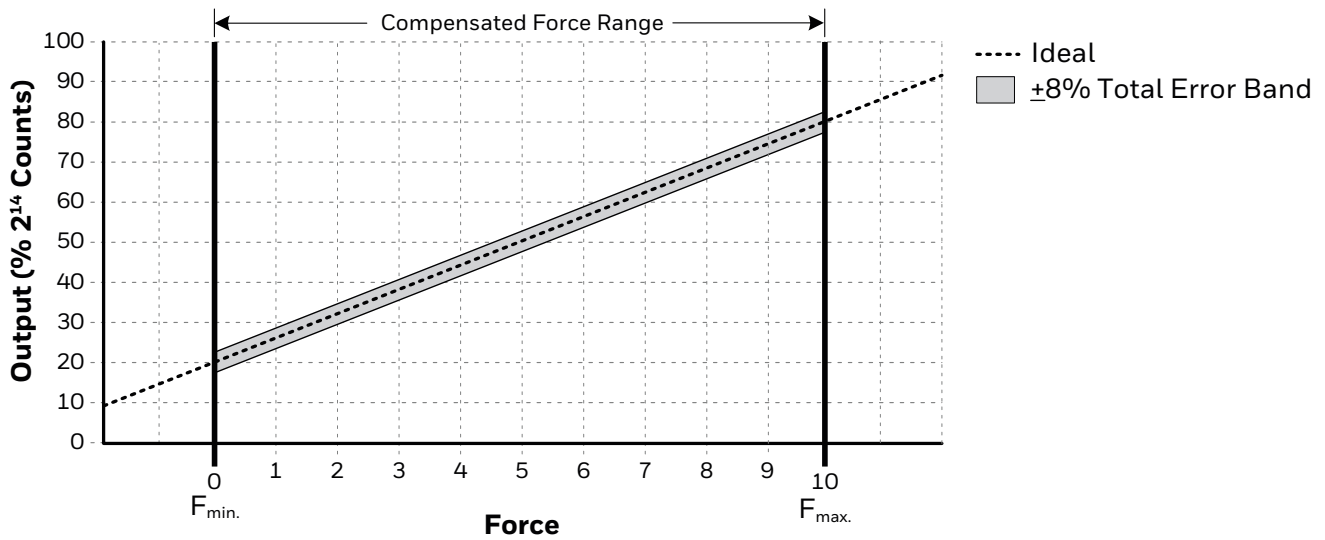

$$\text{Output (\% of } 2^{14} \text{ counts)} = \frac{60\%}{\text{Force}_{\text{range}}} \times (\text{Force}_{\text{applied}}) + 20\%$$

MICROFORCE SENSORS, FMA SERIES

FIGURE 2. NOMENCLATURE AND ORDER GUIDE

For example, **FMAMSDXX025WCSC3** defines an FMA Series Force Sensor, compensated/amplified, mechanically coupled, sphere contact element, sensor short and open diagnostics, 25 N force range, force unit in N, compression force type, SPI digital output, 20% to 80% transfer function, 3.3 Vdc supply voltage¹

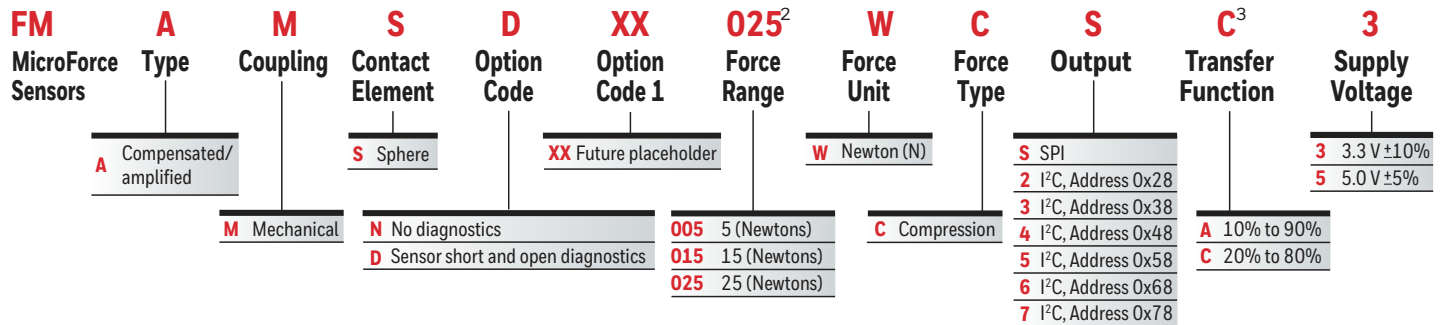

¹ Custom configurations are available upon request. Please contact Honeywell Sales.

² Three characters specify the desired force level; allowable characters are the numbers 0 through 9. See Table 5 for currently configurable force ranges.

³ For other available transfer functions, contact Honeywell Customer Service.

Note: Breakout boards, designed for use with the Honeywell SEB002 Sensor Evaluation Kit, are available with the FMA Series sensor already mounted. Please contact your Honeywell representative for details.

TABLE 5. FMA SERIES AVAILABILITY¹

CATALOG LISTING	FORCE RANGE	OUTPUT	DESCRIPTION
FMAMSDXX005WCSC3	5 N	SPI	FMA Series Force Sensor, compensated/amplified, mechanically coupled, sphere contact element, sensor short and open diagnostics, 5 N force range, compression force type, SPI digital output, 20% to 80% transfer function, 3.3 V ±10% supply voltage
FMAMSDXX005WC2C3		I ² C, address 0x28	FMA Series Force Sensor, compensated/amplified, mechanically coupled, sphere contact element, sensor short and open diagnostics, 5 N force range, compression force type, I ² C digital output, address 0x28, 20% to 80% transfer function, 3.3 V ±10% supply voltage
FMAMSDXX015WCSC3	15 N	SPI	FMA Series Force Sensor, compensated/amplified, mechanically coupled, sphere contact element, sensor short and open diagnostics, 15 N force range, compression force type, SPI digital output, 20% to 80% transfer function, 3.3 V ±10% supply voltage
FMAMSDXX015WC2C3		I ² C, address 0x28	FMA Series Force Sensor, compensated/amplified, mechanically coupled, sphere contact element, sensor short and open diagnostics, 15 N force range, compression force type, I ² C digital output, address 0x28, 20% to 80% transfer function, 3.3 V ±10% supply voltage
FMAMSDXX025WCSC3	25 N	SPI	FMA Series Force Sensor, compensated/amplified, mechanically coupled, sphere contact element, sensor short and open diagnostics, 25 N force range, compression force type, SPI digital output, 20% to 80% transfer function, 3.3 V ±10% supply voltage
FMAMSDXX025WC2C3		I ² C, address 0x28	FMA Series Force Sensor, compensated/amplified, mechanically coupled, sphere contact element, sensor short and open diagnostics, 25 N force range, compression force type, I ² C digital output, address 0x28, 20% to 80% transfer function, 3.3 V ±10% supply voltage

¹ These catalog listings are production released and are readily available. Other configurations per Figure 2 are possible; however, minimum order quantity thresholds and NRE may apply. Please consult the factory.

MICROFORCE SENSORS, FMA SERIES

FIGURE 3. SENSOR MOUNTING DIMENSIONS (FOR REFERENCE ONLY: MM/[IN].)

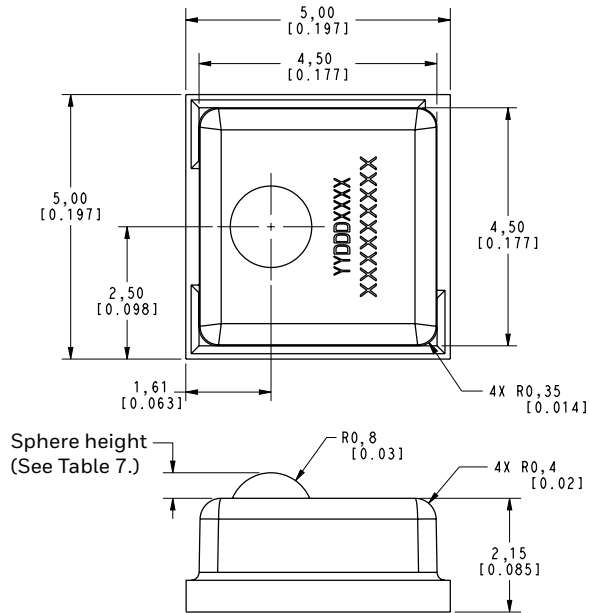
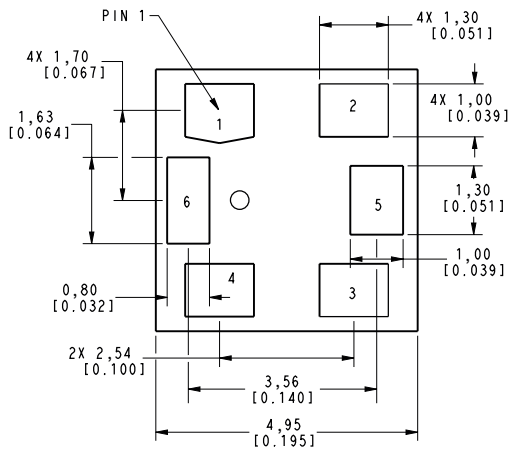

TABLE 6. PINOUT		
PIN	FUNCTION	
	I ² C	SPI
1	VS	VS
2	NC	SS
3	GND	GND
4	SCL	SCLK
5	SDA	MISO
6	NC	NC

TABLE 7. SPHERE FORCE VS HEIGHT	
FORCE (N)	SPHERE HEIGHT (MM)
5	0,293 ±0,075
15	0,393 ±0,075
25	0,483 ±0,075

Solder Pad Layout (viewed from top)



Recommended Land Pattern

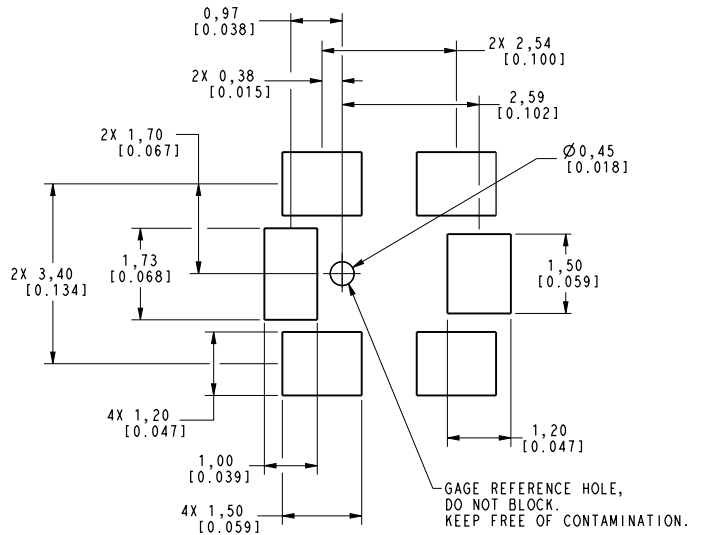

MICROFORCE SENSORS, FMA SERIES

FIGURE 4. REEL MOUNTING DIMENSIONS (FOR REFERENCE ONLY: MM/[IN], ALL DIMENSIONS COMPLY WITH EIA-481-1.)

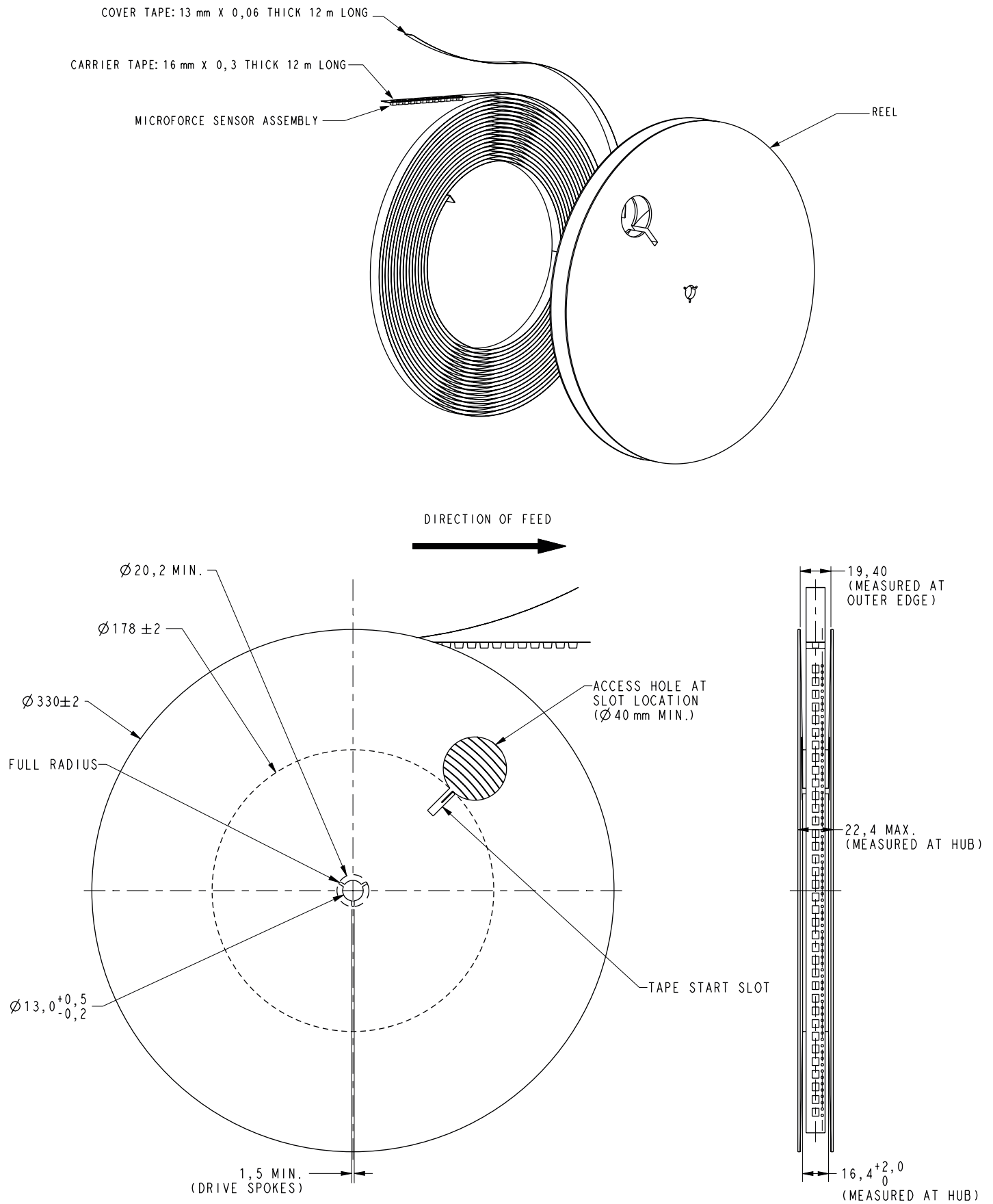

MICROFORCE SENSORS, FMA SERIES

FIGURE 5. TAPE MOUNTING DIMENSIONS (FOR REFERENCE ONLY: MM/[IN], ALL DIMENSIONS COMPLY WITH EIA-481-1.)

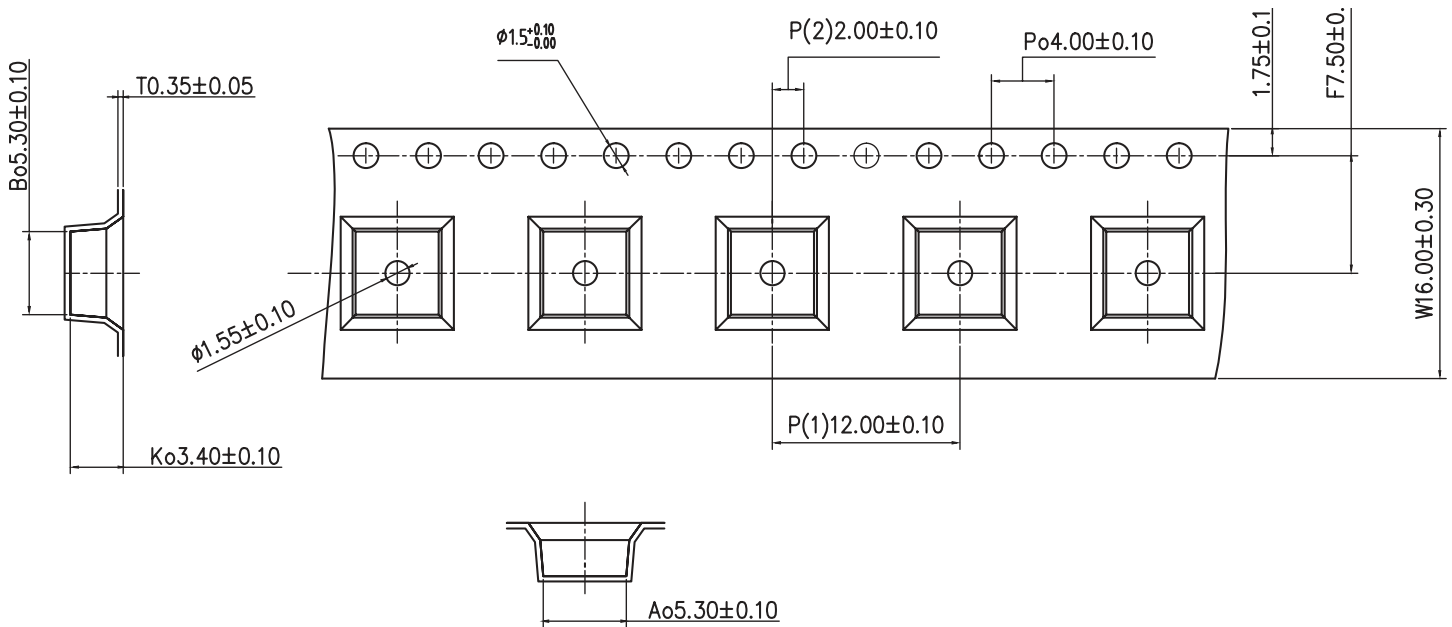

Note: FMA Series products are shipped in tape and reel packaging with a Minimum Order Quantity (MOQ) of 160 pieces. The maximum tape and reel quantity is 960 pieces per reel.

	CAUTION ELECTROSTATIC SENSITIVE DEVICES	
	DO NOT OPEN OR HANDLE EXCEPT AT A STATIC FREE WORKSTATION	
ESD SENSITIVITY: CLASS 3B		

ADDITIONAL MATERIALS

The following associated literature is available at sensing.honeywell.com:

- Product range guide
- Technical notes:
 - MicroForce Sensor Coupling
 - Overforce Design Considerations
 - Force Sensor Diagnostics
 - Digital Output Force Sensors I²C Communications
 - Digital Output Force Sensors SPI Communications
- Other technical notes
- Application notes
- Sell Sheets
- CAD Models

FOR MORE INFORMATION

Honeywell Sensing and Internet of Things services its customers through a worldwide network of sales offices and distributors. For application assistance, current specifications, pricing or the nearest Authorized Distributor, visit sensing.honeywell.com or call:

Asia Pacific	+65 6355-2828
Europe	+44 1698 481481
USA/Canada	+1-302-613-4491

Honeywell Sensing and Internet of Things

830 East Arapaho Road
Richardson, TX 75081
honeywell.com

WARRANTY/REMEDY

Honeywell warrants goods of its manufacture as being free of defective materials and faulty workmanship during the applicable warranty period. Honeywell's standard product warranty applies unless agreed to otherwise by Honeywell in writing; please refer to your order acknowledgment or consult your local sales office for specific warranty details. If warranted goods are returned to Honeywell during the period of coverage, Honeywell will repair or replace, at its option, without charge those items that Honeywell, in its sole discretion, finds defective.

The foregoing is buyer's sole remedy and is in lieu of all other warranties, expressed or implied, including those of merchantability and fitness for a particular purpose. In no event shall Honeywell be liable for consequential, special, or indirect damages.

WARNING PERSONAL INJURY

DO NOT USE these products as safety or emergency stop devices or in any other application where failure of the product could result in personal injury.

Failure to comply with these instructions could result in death or serious injury.

WARNING MISUSE OF DOCUMENTATION

- The information presented in this product sheet is for reference only. Do not use this document as a product installation guide.
- Complete installation, operation, and maintenance information is provided in the instructions supplied with each product.

Failure to comply with these instructions could result in death or serious injury.

While Honeywell may provide application assistance personally, through our literature and the Honeywell web site, it is buyer's sole responsibility to determine the suitability of the product in the application.

Specifications may change without notice. The information we supply is believed to be accurate and reliable as of this writing. However, Honeywell assumes no responsibility for its use.