



Features

- Supply Voltage: 8.5 V
- RF Frequency Range: 1400 MHz to 1550 MHz
- IF Frequency Range: 150 MHz to 250 MHz
- Enhanced IM3 Rejection
- Overall Gain Control Range: 30 dB Typically
- DSB Noise Figure: 10 dB
- Gain-controlled Amplifier and L-band Mixer
- Power-down Function for the Analog Part
- On-chip Gain-control Circuitry
- On-chip VCO, Typical Frequency 1261.568 MHz
- Internal VCO Can Be Overdriven by an External LO
- On-chip Frequency Synthesizer
 - Fixed LO Divider Factor: 2464
 - Nine Selectable Reference Divider Factors : 32, 33, 35, 36, 48, 49, 63, 64, 65
 - A Reference Oscillator (Can Be Overdriven by an External Reference Signal)
 - Tristate Phase Detector with Programmable Charge Pump
 - Programmable Deactivation of Tuning Output
 - Lock-status Indication
 - Test Interface

Electrostatic sensitive device.
Observe precautions for handling.



Description

The U2730B-N is a monolithically integrated L-band down-converter circuit fabricated with Atmel's advanced UHF5S technology. This IC covers all functions of an L-band down-converter in a DAB receiver. The device includes a gain-controlled amplifier, a gain-controlled mixer, an output buffer, a gain control block, a power save function for the analog part, an L-band oscillator and a complete frequency synthesizer unit. The frequency synthesizer block consists of a reference oscillator/buffer, a reference divider, an RF divider, a tri-state phase detector, a loop filter amplifier, a lock detector, a programmable charge pump, a test interface and a control interface.



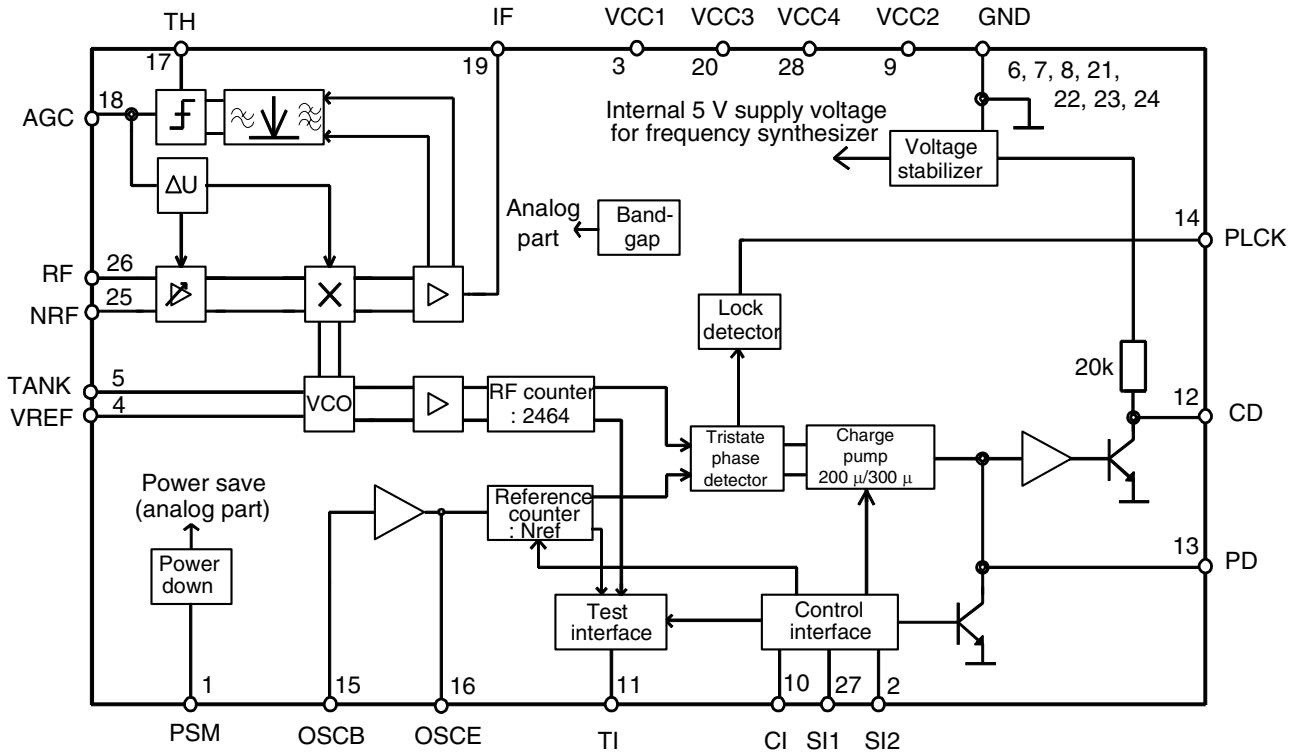
L-band Down-converter for DAB Receivers

U2730B-N

Preliminary

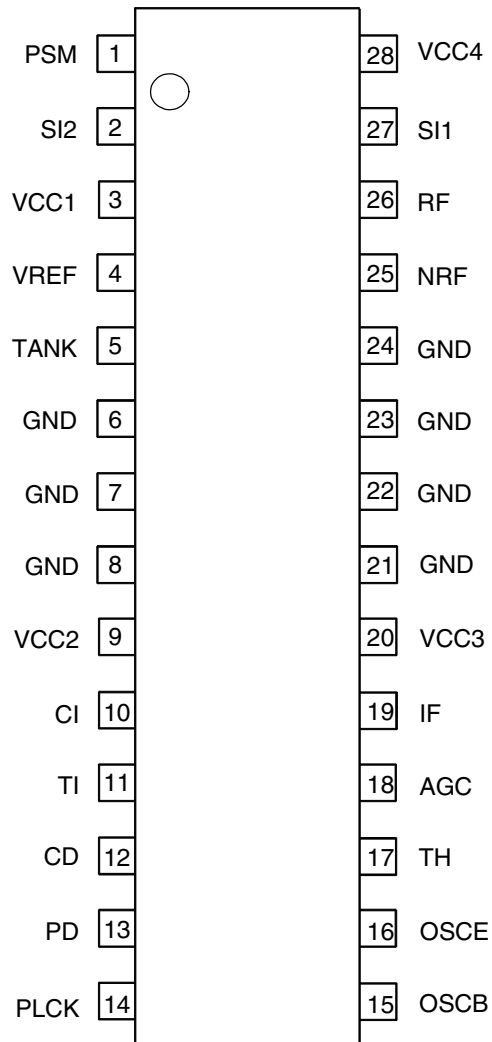


Figure 1. Block Diagram



Pin Configuration

Figure 2. Pinning SSO28



Pin Description

Pin	Symbol	Function
1	PSM	Power save mode
2	SI2	Control input
3	VCC1	Supply voltage VCO
4	VREF	Reference pin of VCO
5	TANK	Tank pin of VCO
6, 7, 8, 21, 22, 23, 24	GND	Ground
9	VCC2	Supply voltage PLL
10	CI	Control input
11	TI	Test interface
12	CD	Active filter output
13	PD	Tristate charge pump output
14	PLCK	Lock-indication output (open collector)
15	OSCB	Input of internal oscillator/buffer
16	OSCE	Output of internal oscillator/buffer
17	TH	Threshold voltage of comparator
18	AGC	Charge-pump output of comparator, AGC input for amplifier and mixer
19	IF	Intermediate frequency output
20	VCC3	Supply voltage
25	NRF	RF input (inverted)
26	RF	RF input
27	SI1	Control input
28	VCC4	Supply voltage

Functional Description

The U2730B-N is an L-band down-converter circuit covering a gain-controlled amplifier, a gain-controlled mixer, an output buffer, a gain control circuitry, an L-band oscillator and a frequency synthesizer block. Designed for applications in a DAB receiver, the circuit down-converts incoming L-band signals in the frequency range of 1452 MHz to 1492 MHz to an IF frequency in a range of 190 MHz to 230 MHz which can be handled by a subsequent DAB tuner. A block diagram of this circuit is shown in Figure 1.

Gain-controlled Amplifier RF signals applied to the 'RF' input pin are amplified by a gain-controlled amplifier. The complementary pin NRF is not internally blocked, it is recommended to block this pin carefully by an external capacitor. The gain-control voltage is generated by an internal gain-control circuitry. The output signal of this amplifier is fed to a gain-controlled mixer.

Gain-controlled Mixer and Output Buffer The purpose of this mixer is to down-convert the L-band signal in the frequency range of 1452 MHz to 1492 MHz to an IF frequency in the range of about 190 MHz to 230 MHz. Like the amplifier, the gain of the mixer is controlled by the gain-control circuitry. The IF signal is buffered and filtered by a one-pole low-pass filter at a 3 dB frequency of about 500 MHz, and then it is fed to the single-ended output pin IF.

Gain-control Circuitry The gain-control circuitry measures the signal power, compares it with a certain power level and generates control voltages for the gain-controlled amplifier and mixer. An equivalent circuit of this functional block is shown in Figure 6.

In order to meet this functionality, the output signal of the buffer amplifier is weakly band-pass filtered (transition range of about 60 MHz to 550 MHz), rectified, low-pass filtered and fed to a comparator whose threshold can be defined by an external resistor, RTH, at pin TH. By varying the value of this resistor, a power threshold of about -33 dBm to -20 dBm can be selected. In order to achieve a good intermodulation ratio, it is recommended to keep the power threshold below -25 dBm. An appropriate application is shown in Figure 3. Depending on the selection made by the comparator, a charge pump charges or discharges a capacitor which is applied to the AGC pin. By varying this capacitor, different time constants of the AGC loop can be realized. The voltage arising at the AGC pin is used to control the gain setting of the gain-controlled amplifier and mixer. The voltage at pin AGC is in the range of 5.75 V for maximum gain and 0.3 V for minimum gain. This voltage can be used to control a dual-gate GaAs-FET in front of the U2730B-N to achieve an extended AGC range. By applying an external voltage to the AGC pin, the internal AGC loop can be overdriven.

Voltage-controlled Oscillator

A voltage-controlled oscillator supplies a LO signal to the mixer. An equivalent circuit of this oscillator is shown in Figure 7. In the application circuits Figure 8 and Figure 9, a ceramic coaxial resonator is applied to the oscillator's TANK and VREF pins. It should be noted that V_{ref} has to be blocked carefully. Figure 9 shows a different application where the oscillator is overdriven by an external oscillator. In any case, a DC path at a low impedance must be established between the TANK and VREF pins. The output signal of the oscillator is fed to the LO divider block of the frequency synthesizer unit which locks the VCO's frequency on the frequency of a reference oscillator. Figure 5 shows the typical phase-noise performance of the oscillator in locked state.

Overall Properties of the Signal Path

The overall gain of this circuit amounts to 24 dB, the gain-control range is about 30 dB. With a new AGC concept in the amplifier and mixer, the U2730B-N reaches better inter-modulation distances (DIM3) at higher IF output power levels.

Power Save Mode

For $V_{PSSM} > 2\text{ V}$ (pin 1) the power consumption in the analog part (gain-controlled amplifier and mixer and gain-controlled circuitry) is reduced by 80%. The VCO and the PLL is not influenced by the power-down mode.

Frequency Synthesizer

The frequency synthesizer block consists of a reference oscillator, a reference divider, a LO divider in order to divide the frequency of the internal oscillator, a tri-state phase detector, a lock detector, a programmable charge pump, a loop filter amplifier, a control interface and a test interface. The control interface is accessed by three control pins, CI, SI1 and SI2. The test interface provides test signals which represent output signals of the reference and the LO divider.

The purpose of this unit is to lock the frequency f_{VCO} of the internal VCO on the frequency f_{ref} of the reference signal applied to the input pin OSCB phase-locked loop according to the following relation:

$$f_{VCO} = SF \times f_{ref} / SF_{ref}$$

where: $SF = 2464$,

SF_{ref} is the scaling factor of the reference divider according to Table 1

Table 1. Scaling Factors of the Reference Frequency

Voltage at Pin SI1	Voltage at Pin SI2	SF_{ref}	Reference Oscillator Frequency
GND	OPEN	36	18.432 MHz
GND	VCC	33	–
GND	GND	48	24.576 MHz
OPEN	OPEN	65	–
OPEN	VCC	63	–
OPEN	GND	64	32.768 MHz
VCC	OPEN	35	17.920 MHz
VCC	VCC	32	16.384 MHz
VCC	GND	49	–

Reference Oscillator

An on-chip crystal oscillator generates the reference signal which is fed to the reference divider. By connecting a quartz crystal to pins OSCE and OSCB according to Figure 10, this oscillator generates a highly stable reference signal. The U2731B (Atmel's one-chip front-end IC) offers the reference signal at pin FREF. This reference signal (LC-filtered to suppress harmonics) can be used to overdrive the oscillator. In this application (see Figure 11) the reference signal has to be applied to the pin OSCB and the pin OSCE must be left open.

Reference Divider

Nine different scaling factors of the reference divider can be selected by different voltage settings at the input pins SI1, SI2: 32, 33⁽¹⁾, 35, 36, 48, 49⁽¹⁾, 65⁽¹⁾, 64, 63⁽¹⁾. The reference divider factors result in reference oscillator frequencies shown in Table 1.

Note: 1. These scaling factors result in an output frequency of the reference divider of 512 kHz. If harmonics of the Bd. 3 VCO are falling in the L-band reception band, this spurious can influence the AGC of U2730B-N. That could be a problem for small incoming signals. In this case it is possible to switch the reference divider from nref to nref+1.

LO Divider

The LO divider is operated at the fixed division ratio 2464. Assuming the settings described in the section “Reference Divider”, the oscillator's frequency is controlled to be 1261.568 MHz in locked state and the output frequency of the RF divider is 512 kHz.

Phase Comparator, Charge Pump and Loop Filter

The tri-state phase detector causes the charge pump to source or to sink current at the output pin PD depending on the phase relation of its input signals which are provided by the reference and the RF divider respectively. By means of the control pin CI, two different values of this current can be selected, and furthermore the charge-pump current can be switched off.

The input of the high-gain amplifier (output pin CD) which is implemented in order to construct a loop filter, as shown in the application circuit, can be switched to GND by means of the control pin CI (see Table 2). In the application circuit, the loop filter is completed by connecting the pins PD and CD by an appropriate RC network.

Lock Detector

An internal lock detector checks if the phase difference of the input signals of the phase detector is smaller than approximately 250 ns in seven subsequent comparisons. If a phase lock is detected, the open collector output pin PLCK is set to HIGH. It should be noted that the output current of this pin must be limited by external circuitry as it is not limited internally. If the voltage at the control pin CI is chosen to be half the supply voltage, or if this control pin is left open, the lock-detector function is deactivated and the logical value of the PLCK output is undefined.

Test Interface

If the input control pin CI is left open (high impedance state), a test signal which monitors the output frequency of the reference divider appears at the output pin TI.

In analogy to the reference divider a test signal which monitors the output frequency of the RF divider appears at the test interface output pin TI if the input control pin CI is connected to VCC/2.

Table 2. Control Interface (CI) Settings

CI	PD	PLCK	TI
GND	200 μ A	ok	–
Vs	300 μ A	ok	–
VCC/2	0 μ A	Undefined	RF divider
Open	Connected to GND	Undefined	Reference divider

Absolute Maximum Ratings

Parameters	Pins	Symbol	Value	Unit
Supply voltage	3, 9, 20 and 28	V_{CC}	-0.3 to +9.5	V
RF input voltage	25 and 26	V_{RF}	750	mV _{pp}
Voltage at pin AGC	18	V_{AGC}	0.5 to 6	V
Voltage at pin TH	17	V_{TH}	-0.3 to +4.0	V
Input voltage at pin TANK (internal oscillator overdriven)	5	V_{TANK}	1	V _{pp}
Current at IF output	19	I_{IF}	4.0	mA
Reference input voltage (diff.)	15	OSCB	1	V _{pp}
Control input voltage	1, 2, 10 and 27	CI, SI1, SI2, PD	-0.3 to +9.5	V
PLCK output current	14	I_{PLCK}	0.5	mA
PLCK output voltage	14	V_{PLCK}	-0.3 to +5.5	V
Junction temperature		T_j	125	°C
Storage temperature		T_{stg}	-40 to +125	°C

Operating Range

Parameters	Pins	Symbol	Value	Unit
Supply voltage	3, 9, 20 and 28	V_{CC}	8 to 9.35	V
Ambient Temperature		T_{amb}	-40 to +85	°C

Thermal Resistance

Parameters	Symbol	Value	Unit
Junction ambient SSO28 (mod.)	R_{thJA}	50	K/W

Electrical Characteristics

Operating conditions: $V_{CC} = 8.5$ V, $T_{amb} = 25$ °C, see application circuit (Figure 8), unless otherwise specified

No.	Parameters	Test Conditions	Pin	Symbol	Min.	Typ.	Max.	Unit	Type*
	Supply current (max. gain)	$p_{RF} = -60$ dBm $V_{PSM} < 0.5$ V		$I_{S,MAX}$		40	48	mA	A
	Supply current (min. gain)	$p_{RF} = -10$ dBm $V_{PSM} < 0.5$ V		$I_{S,MIN}$		41	50	mA	B
	Supply current (power save mode)	$p_{RF} = -10$ dBm $V_{PSM} > 2$ V		$I_{S,PD}$		20	24	mA	A
Amplifier Mixer Pin 26				26 → 19					
	Maximum conversion gain	$p_{RF} = -60$ dBm		$g_{c,max}$	20	24		dB	A
	Minimum conversion gain	$p_{RF} = -15$ dBm		$g_{c,min}$		-8		dB	B
	AGC range			Δg_c	28	32		dB	A
	Third order 2 tone intermodulation ratio	$p_{RF1} + p_{RF2} = -10$ dBm $p_{RF1} + p_{RF2} = -15$ dBm		dim3	30 35	35 40		dB dB	B A

*) Type means: A = 100% tested, B = 100% correlation tested, C = Characterized on samples, D = Design parameter

Electrical Characteristics (Continued)

Operating conditions: $V_{CC} = 8.5\text{ V}$, $T_{amb} = 25^\circ\text{C}$, see application circuit (Figure 8), unless otherwise specified

No.	Parameters	Test Conditions	Pin	Symbol	Min.	Typ.	Max.	Unit	Type*
	DSB noise figure (50- Ω system)	Maximum gain Minimum gain		NF		10 30		dB dB	D
RF Input			26						
	Frequency range			$f_{in,RF}$	1400		1550	MHz	C
	Maximum input power	$dim3 \geq 20\text{ dB}$		$P_{in,max,RF}$		-6		dBm	C
	Input impedance			$Z_{in,RF}$		200 1		Ω pF	D
IF Output			19						
	Frequency range			$f_{out,IF}$	150		250	MHz	C
	Output impedance			$Z_{out,IF}$		50		Ω	D
	Voltage standing wave ratio			$VSWR_{IF}$		2.0			D
Gain Control									
	Threshold adjustment	External resistor	17	R_{TH}		100		k Ω	D
	Charge pump current	$P_{RF} = -10\text{ dBm}$ $V_{AGC} = 3.5\text{ V}$	18	$I_{CP,P}$	75	100	125	μA	A
		$P_{RF} = -60\text{ dBm}$ $V_{AGC} = 3.5\text{ V}$		$I_{CP,N}$	-125	-100	-75	μA	A
	Minimum gain control voltage	$P_{RF} = -10\text{ dBm}$	18	V_{AGCmin}		0.1	0.6	V	A
	Maximum gain control voltage	$P_{RF} = -60\text{ dBm}$	18	V_{AGCmax}	5.5	5.75		V	A
VCO			5						
	Frequency			f_{LO}	1000	1261.568	1500	MHz	
	Phase noise	1 kHz distance		L_{1kHz}		-75		dBc/Hz	C
	Minimum input power	VCO over-driven, see "Application Circuit" (Figure 8)		$P_{LO,MIN}$		-11		dBm	C
	Maximum input power			$P_{LO,MAX}$		-5		dBm	C
Frequency Synthesizer									
	RF divide factor			SF		2464			A
	Reference divide factor	SI1 = GND, SI2 = GND		SF_{ref}		48			A
		SI1 = GND, SI2 = VCC			33				
		SI1 = GND, SI2 = open			36				
		SI1 = VCC, SI2 = GND			49				
		SI1 = VCC, SI2 = VCC			32				
		SI1 = VCC, SI2 = open			35				
		SI1 = open, SI2 = GND			64				
		SI1 = open, SI2 = VCC			63				
	SI1 = open, SI2 = open		65						
	Input frequency range			f_{ref}	5		50	MHz	C
	Input sensitivity		15	V_{refs}			30	mV _{rms}	C
	Maximum input signal		15	V_{refmax}		300		mV _{rms}	C
	Input impedance	Single-ended		Z_{ref}		2.7k 2.5		k Ω pF	D

*) Type means: A = 100% tested, B = 100% correlation tested, C = Characterized on samples, D = Design parameter

Electrical Characteristics (Continued)

Operating conditions: $V_{CC} = 8.5\text{ V}$, $T_{amb} = 25^\circ\text{C}$, see application circuit (Figure 8), unless otherwise specified

No.	Parameters	Test Conditions	Pin	Symbol	Min.	Typ.	Max.	Unit	Type*
Phase Detector									
	Charge-pump current	Pin CI connected to GND	13	I_{PD2}	160	200	240	μA	A
		Pin CI connected to VCC		I_{PD1}	240	300	360	μA	A
		Pin CI connected to $V_{CC}/2$		$I_{PD1,tri}$			100	nA	A
	Output voltage PD	Pin CI open, Pin	13	V_{PD}			0.3	V	A
	Internal reference frequency			f_{PD}		512		kHz	B
	Typical tuning voltage range		12	V_{tune}	0.3		5	V	C
Lock Indication PLCK 14									
	Leakage current	$V_{PLCK} = 5.5\text{ V}$		I_{PLCK}			10	μA	A
	Saturation voltage	$I_{PLCK} = 0.25\text{ mA}$		$V_{PLCK,sat}$			0.5	V	A
Control Inputs SI 2 and 27									
	Input voltage	Pin connected to GND		V_L	0		0.1	V_{CC}	A
		Pin open		V_M		open			A
		Pin connected to V_{CC}		V_H	0.9		1	V_{CC}	A
Control Input CI 10									
	Input voltage	Pin connected to GND		V_L	0		0.1	V_{CC}	A
		Pin connected to $V_{CC}/2$		V_M		0.5		V_{CC}	A
		Pin open		V_{open}		open			A
		Pin connected to V_{CC}		V_H	0.9		1	V_{CC}	A
Test Interface TI 11									
	Reference test frequency	Pin CI open		$f_{test,ref}$		512		kHz	B
	LO test frequency	Pin CI = $V_{CC}/2$		$f_{test,LO}$		512		kHz	B
	Voltage swing	$R_{load} \geq 1\text{ M}\Omega$, $C_{load} \leq 15\text{ pF}$, Pin CI open or $V_{CC}/2$		V_{sw}		400		mV_{pp}	C
Power-save Mode PSM 1									
		PSM not active		V_{PSM}			0.6	V	A
		PSM active		V_{PSM}	2.0			V	A

*) Type means: A = 100% tested, B = 100% correlation tested, C = Characterized on samples, D = Design parameter

Example: reference divider factor = 35, $f_{REF} = 17.92\text{ MHz}$, charge-pump current = $200\text{ }\mu\text{A}$

**Gain Control
Charateristics**

Operating conditions: $V_{CC} = 8.5\text{ V}$, $T_{amb} = 27^\circ\text{C}$, $f_{RF} = 1490\text{ MHz}$, $F_{LO} = 1261.568\text{ MHz}$

Figure 3. IF Output Power (Pin 19)

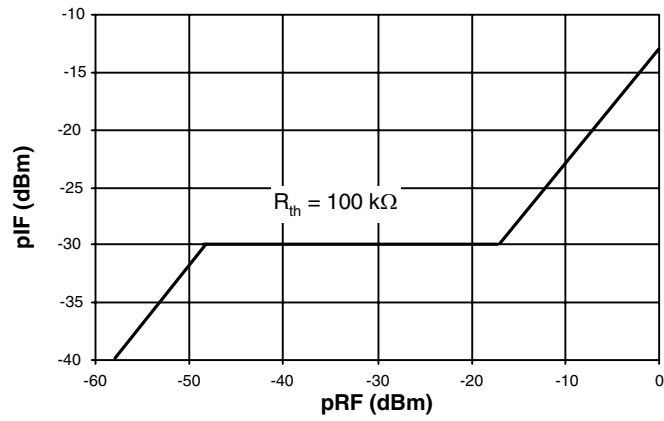
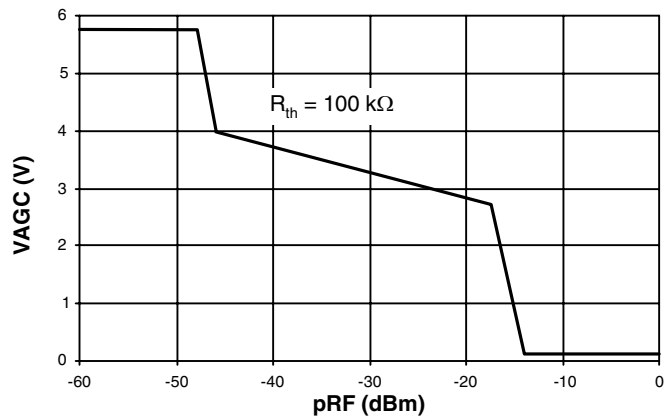


Figure 4. Gain Control Voltage (Pin 11)



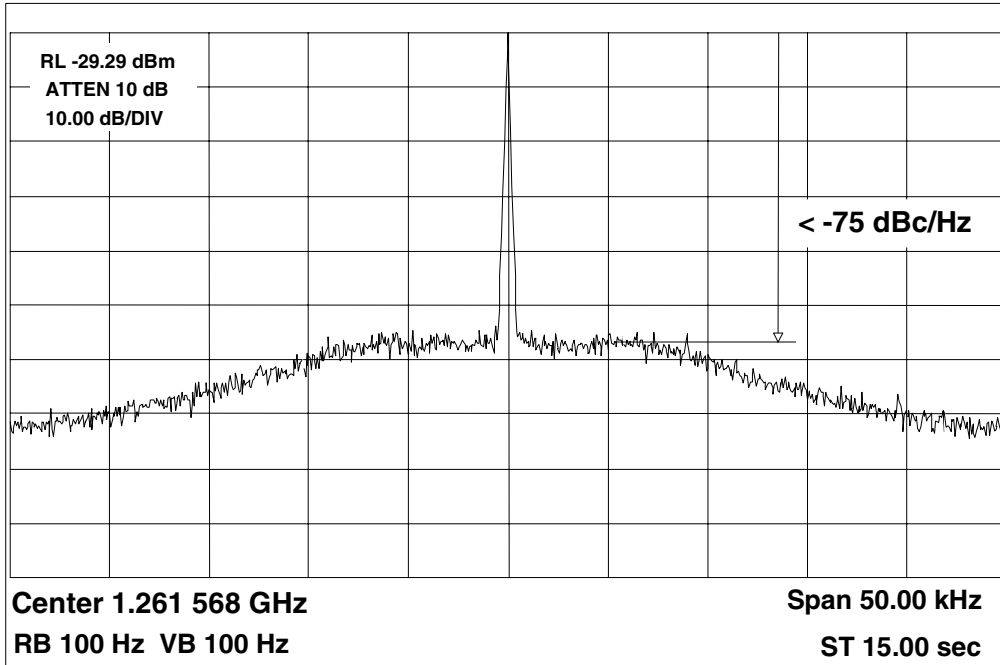
Phase-noise Performance

Measurement conditions:

Values acquired at Pin 19 with HP 70000 spectrum analyzer. RF input (Pin 26) is blocked with 100 pF to GND.

A low phase-noise signal generator (Marconi 2042) was taken as PLL reference.

Figure 5. Phase-noise Performance operating Conditions: $f_{REF} = 17.92 \text{ MHz}$, -10 dB , $I_{PD} = 200 \mu\text{A}$



Equivalent Circuits

Figure 6. AGC Control Circuit

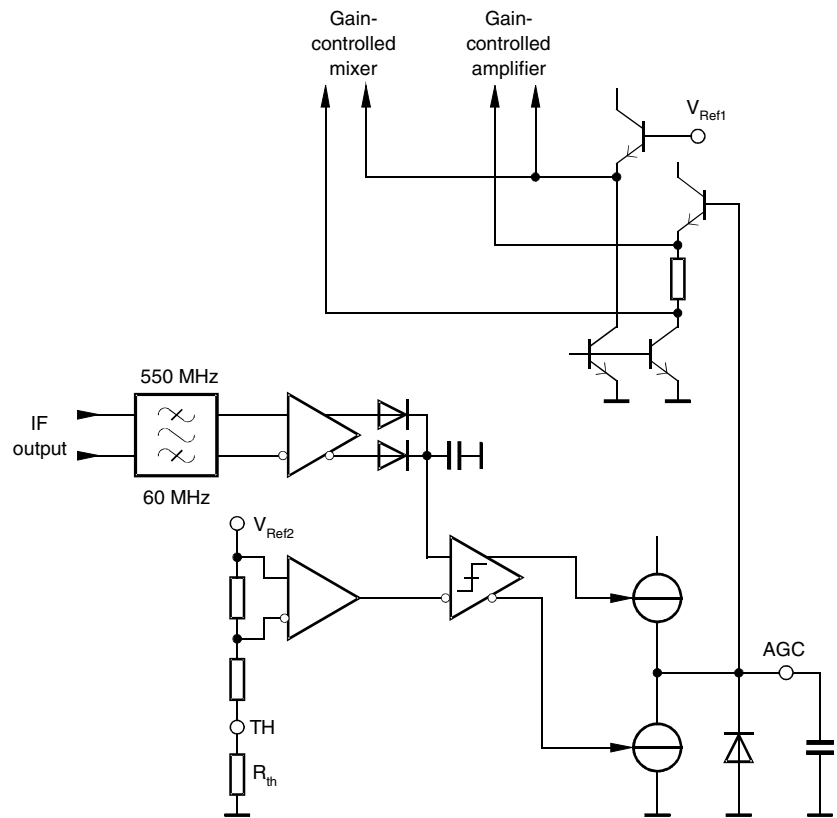
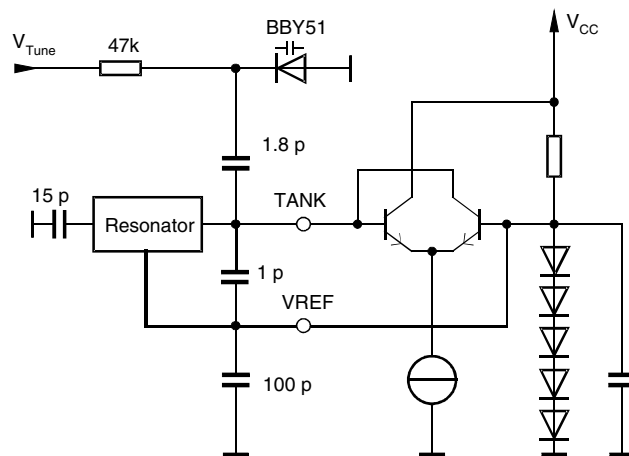
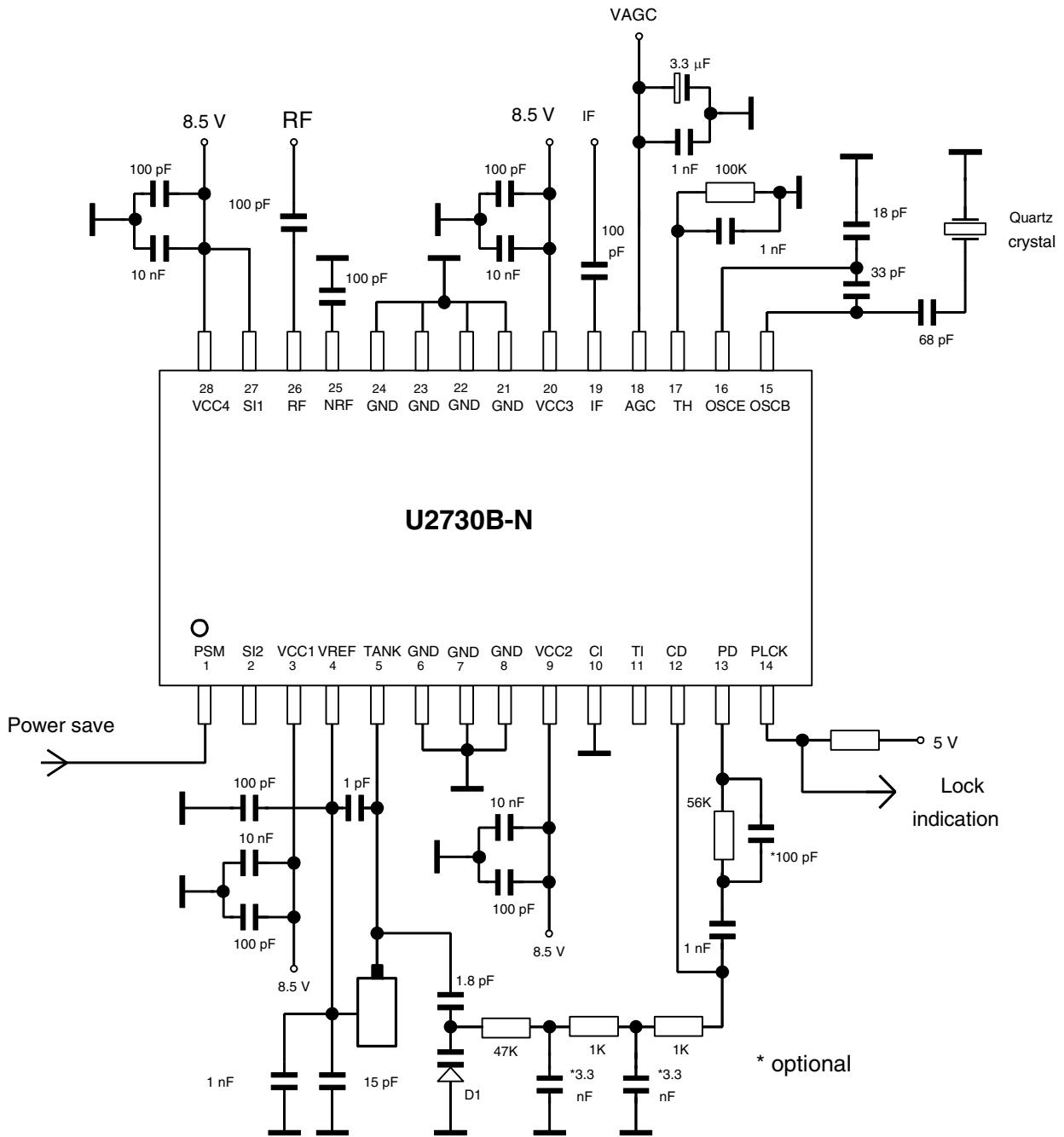


Figure 7. VCO Circuit



Resonator: Ceramic coaxial resonator
Murata 3 x 3 mm, 1.6 GHz
DRR030 KE1R600TC

Figure 8. Application Circuit



Application Circuit for External LO Signal

With an external LO signal it is possible to overdrive the VCO. In this case, the internal VCO acts as a LO buffer.

Figure 9. Application Circuit for External LO Signal

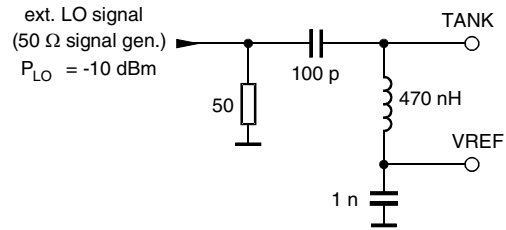


Figure 10. Reference Oscillator Operation

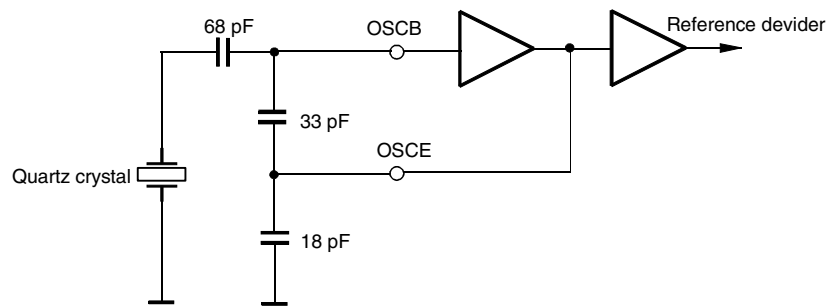
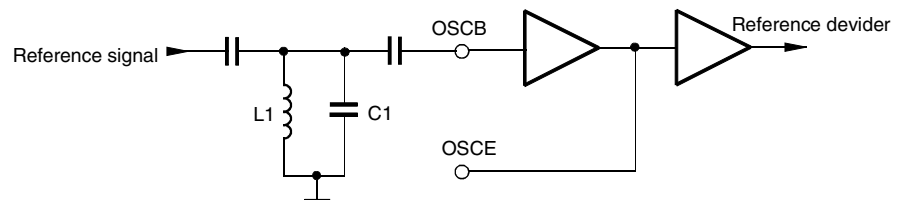


Figure 11. Reference Oscillator Overdriven



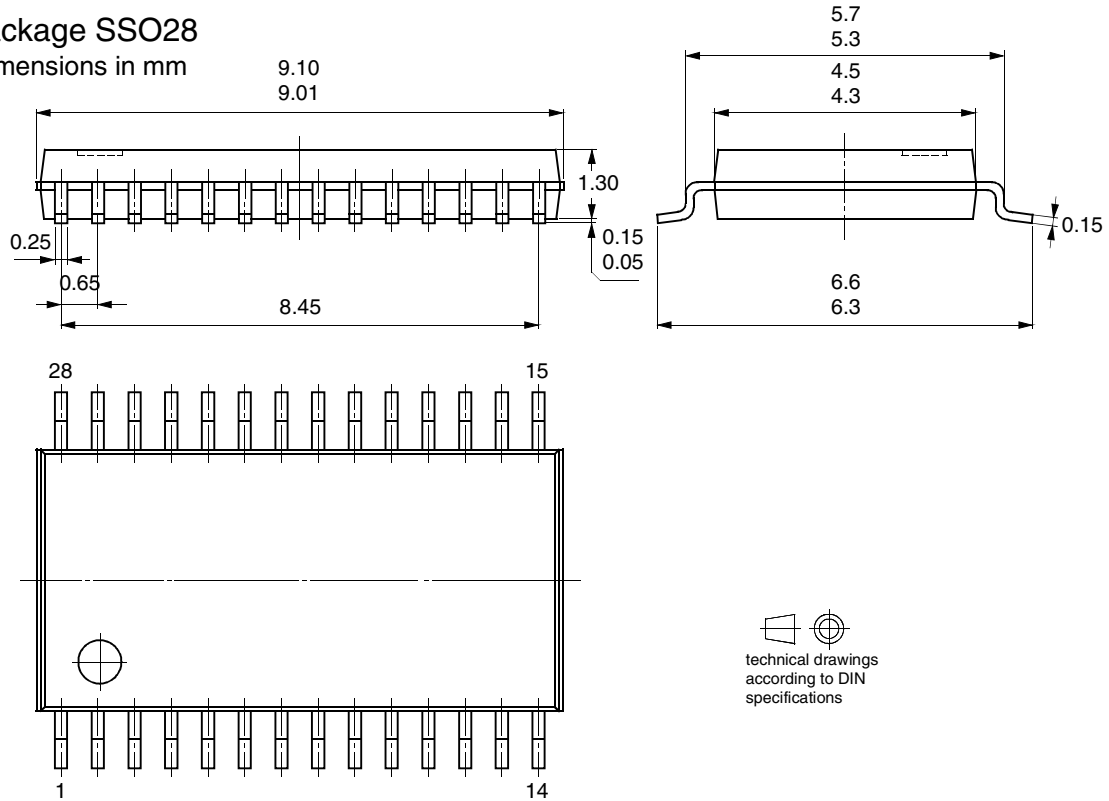
Ordering Information

Extended Type Number	Package	Remarks
U2730B-NFS	SSO28	Tube
U2730B-NFSG1	SSO28	Taped and reeled according to IEC 286-3

Package Information

Package SSO28

Dimensions in mm



technical drawings
 according to DIN
 specifications



Atmel Corporation

2325 Orchard Parkway
San Jose, CA 95131
Tel: 1(408) 441-0311
Fax: 1(408) 487-2600

Regional Headquarters

Europe

Atmel Sarl
Route des Arsenalux 41
Case Postale 80
CH-1705 Fribourg
Switzerland
Tel: (41) 26-426-5555
Fax: (41) 26-426-5500

Asia

Room 1219
Chinachem Golden Plaza
77 Mody Road Tsimshatsui
East Kowloon
Hong Kong
Tel: (852) 2721-9778
Fax: (852) 2722-1369

Japan

9F, Tonetsu Shinkawa Bldg.
1-24-8 Shinkawa
Chuo-ku, Tokyo 104-0033
Japan
Tel: (81) 3-3523-3551
Fax: (81) 3-3523-7581

Atmel Operations

Memory

2325 Orchard Parkway
San Jose, CA 95131
Tel: 1(408) 441-0311
Fax: 1(408) 436-4314

Microcontrollers

2325 Orchard Parkway
San Jose, CA 95131
Tel: 1(408) 441-0311
Fax: 1(408) 436-4314

La Chantrerie
BP 70602
44306 Nantes Cedex 3, France
Tel: (33) 2-40-18-18-18
Fax: (33) 2-40-18-19-60

ASIC/ASSP/Smart Cards

Zone Industrielle
13106 Rousset Cedex, France
Tel: (33) 4-42-53-60-00
Fax: (33) 4-42-53-60-01

1150 East Cheyenne Mtn. Blvd.
Colorado Springs, CO 80906
Tel: 1(719) 576-3300
Fax: 1(719) 540-1759

Scottish Enterprise Technology Park
Maxwell Building
East Kilbride G75 0QR, Scotland
Tel: (44) 1355-803-000
Fax: (44) 1355-242-743

RF/Automotive

Theresienstrasse 2
Postfach 3535
74025 Heilbronn, Germany
Tel: (49) 71-31-67-0
Fax: (49) 71-31-67-2340

1150 East Cheyenne Mtn. Blvd.
Colorado Springs, CO 80906
Tel: 1(719) 576-3300
Fax: 1(719) 540-1759

Biometrics/Imaging/Hi-Rel MPU/ High Speed Converters/RF Datacom

Avenue de Rochepleine
BP 123
38521 Saint-Egreve Cedex, France
Tel: (33) 4-76-58-30-00
Fax: (33) 4-76-58-34-80

e-mail

literature@atmel.com

Web Site

<http://www.atmel.com>

Disclaimer: Atmel Corporation makes no warranty for the use of its products, other than those expressly contained in the Company's standard warranty which is detailed in Atmel's Terms and Conditions located on the Company's web site. The Company assumes no responsibility for any errors which may appear in this document, reserves the right to change devices or specifications detailed herein at any time without notice, and does not make any commitment to update the information contained herein. No licenses to patents or other intellectual property of Atmel are granted by the Company in connection with the sale of Atmel products, expressly or by implication. Atmel's products are not authorized for use as critical components in life support devices or systems.

© Atmel Corporation 2003. All rights reserved.

Atmel® and combinations thereof are the registered trademarks of Atmel Corporation or its subsidiaries.

Other terms and product names may be the trademarks of others.



Printed on recycled paper.