

DO NOT SCALE
DIMENSIONS IN mm

METRIC

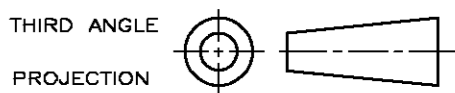

NOTES:

- ① BARREL TERMINALS WILL ACCEPT ONE OR TWO WIRES OF THE SAME SIZE PER TERMINAL.
WIRE SIZE FOR SOLID AND STRANDED WIRES:
0,12 mm² (26 AWG)–0,35 mm² (22 AWG).
MAXIMUM INSULATION DIA. 1,2 mm.
- ② STUFFER CAP IS SHIPPED NOT ASSEMBLED.
- ③ MATERIALS: STUFFER CAP – A.B.S. UL 94HB
BARREL TERMINALS – PHOS.BRONZE, PRE-TINPLATED.
CONTACTS – PHOS.BRONZE, PLATED 1,25µm
SELECTIVE GOLD OVER 1,25µm NICKEL.
HOUSING – PBT, UL 94HB
- ④ FOR 216005-4 DIMENSION 15,2 IS 14,6 ,
CORRESPONDING WITH THE MARKED DASH LINES

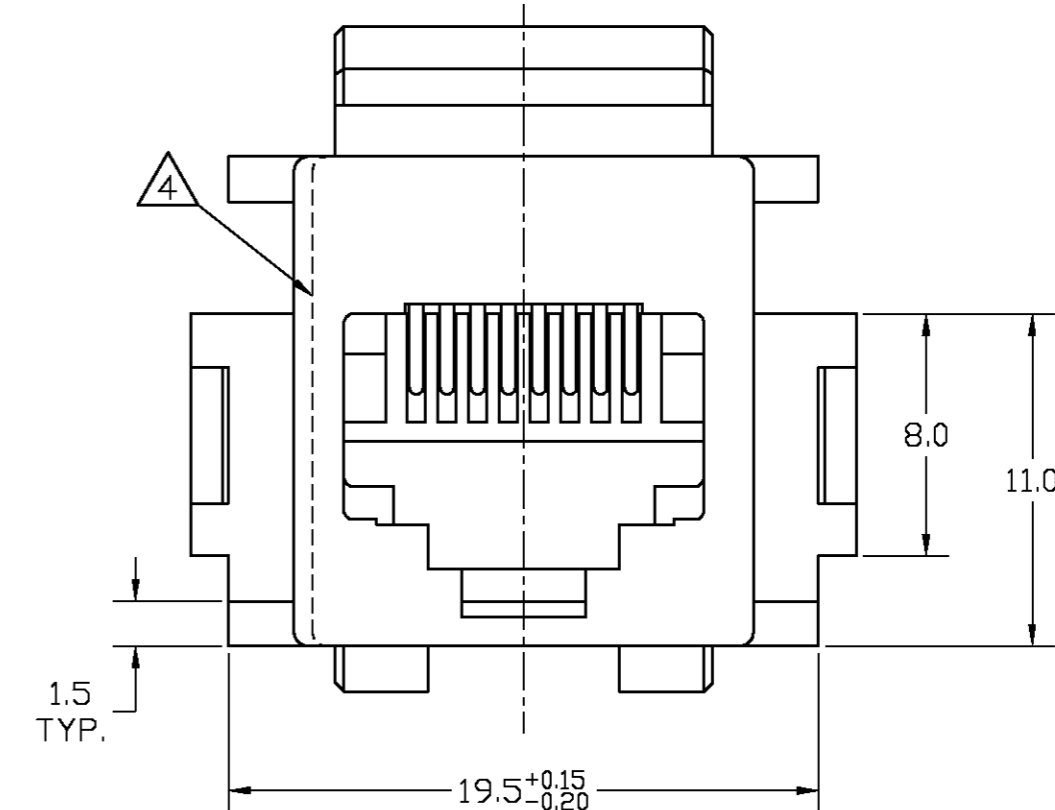
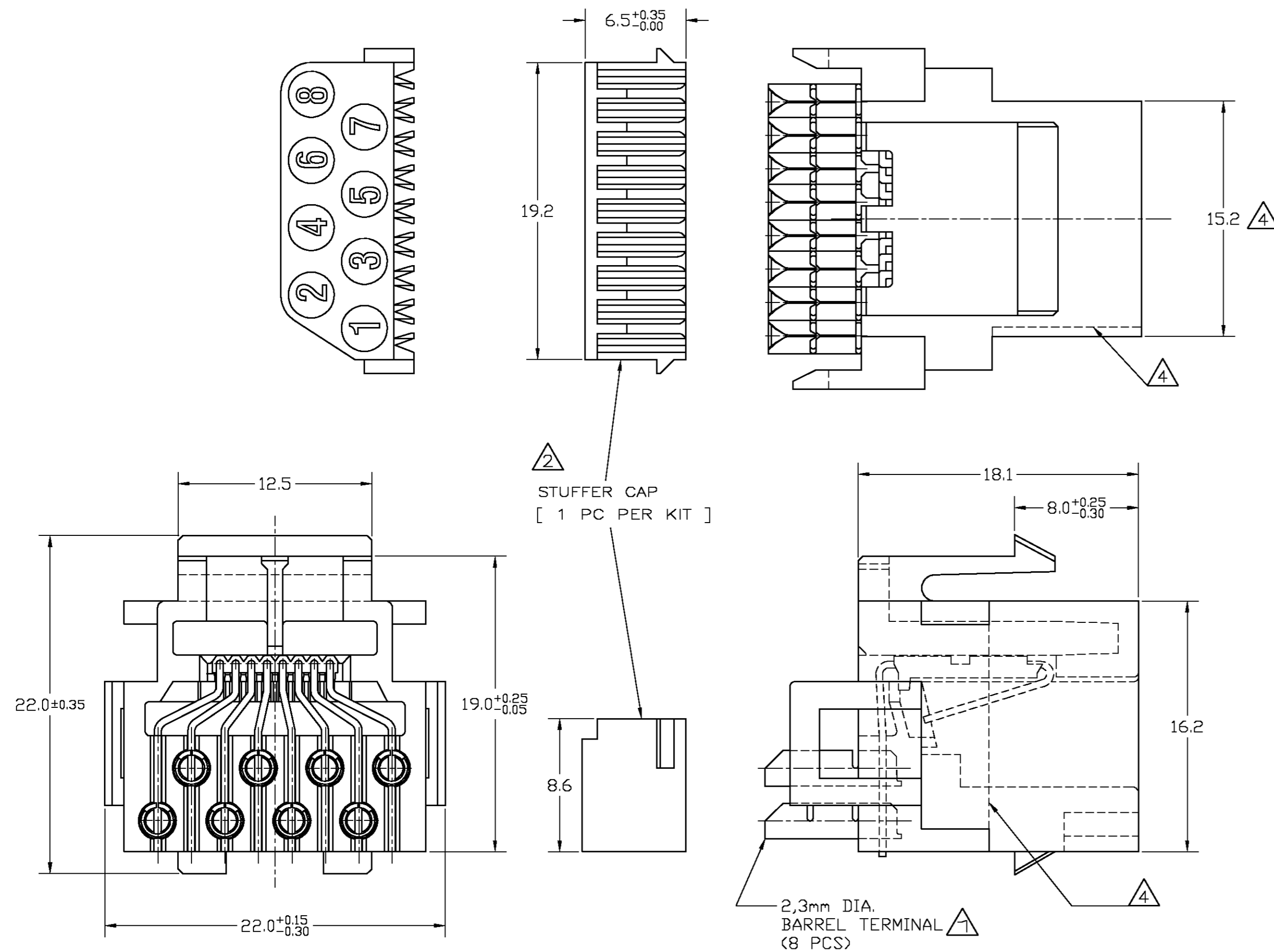

SUGGESTED PANEL CUTOUT DIMENSIONS

SCALE 2 : 1

X-216005-1

X-216005-4 AND X-216005-5

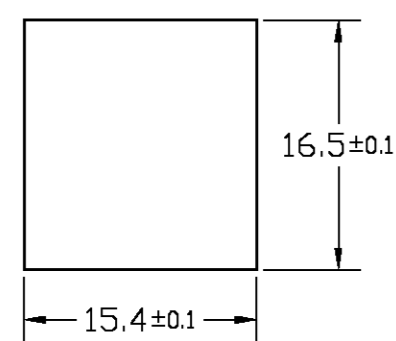
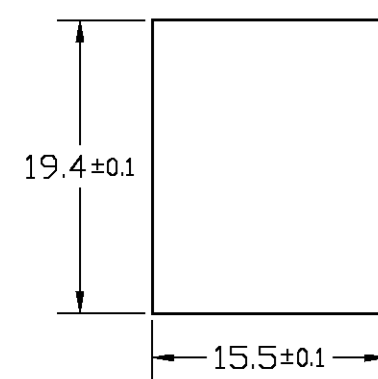

CUTOUT FOR
BACK PANEL
MOUNTING

CUTOUT FOR
FRONT PANEL
MOUNTING

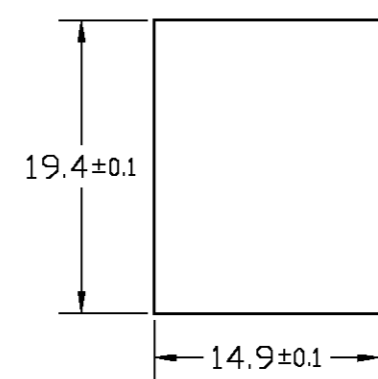

CUTOUT FOR
BACK PANEL
MOUNTING

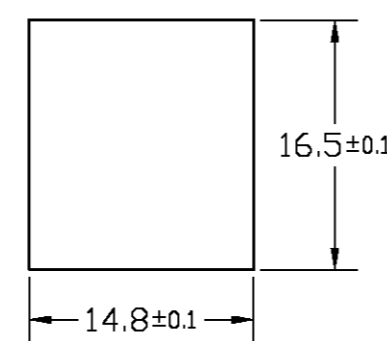

CUTOUT FOR
FRONT PANEL
MOUNTING

PANEL THICKNESS: 1,6 mm NOMINAL

TOLERANCE: ±0,15 UNLESS SPECIFIED OTHERWISE

500 PCS. IN A BOX	SEE NOTE ③	HOUSING COLOR: BLACK ③ SEE NOTE ③	216005-4 216005-1
PACKAGING	FINISH	MATERIAL	PARTNUMBER

CUSTOMER DRAWING FOR REFERENCE ONLY
WILL NOT BE UPDATED

THIS DRAWING IS UNPUBLISHED
RELEASED FOR PUBLICATION



P1	REVISED PER ECO-11-005294	RK	HMR	05APR11
LTR.	REVISION RECORD	DR.	CHK.	DATE

DR.: J.V.LIEMPT	CHK.: W.BRUMMANS	APP.: L. SOEST
DATE: 21 JAN 91	DATE:	DATE: 12 OCT 99

DWG.No.	C-216005	REV.LTR.	P1	SHEET	1 OF 1
---------	----------	----------	----	-------	--------

NAME	TOOLLESS MODULAR JACK KIT
	8 POS., FOR DISCRETE WIRES