

ELECTRICAL:

EMI SHIELDING : SHIELDED FOR THE RANGE 55dB UP TO 100MHZ  
 INSULATION RESISTANCE : >500MΩ PER ANSI-EIA-364-D METHOD 21  
 MAX. CURRENT RATING : SEE INSULATOR DRAWING  
 CONNECTOR TESTING VOLTAGE : SEE INSULATOR DRAWING  
 CONNECTOR WORKING VOLTAGE : SEE INSULATOR DRAWING

PHYSICAL:

MAXIMUM WIRE SIZE USED : SEE INSULATOR DRAWING  
 CABLE DIAMETER WITH PLASTIC COLLET SET SUPPLIED: Ø3.5mm MIN. TO Ø9.7mm MAX.

ENVIRONMENTAL:

ENDURANCE: 1000 CYCLES AS PER MIL-STD 1344A, METHOD 2016.1  
 SHOCK: 50 g , DURATION 6 ms; AS PER MIL-STD 1344A, METHOD 2004.1  
 VIBRATIONS: 10 TO 2000Hz g = 15g, AS PER MIL-STD 1344A, METHOD 2005.1  
 PROTECTION INDEX: IP 67 AS PER CEI 529  
 ROHS COMPLIANT  
 SALT MIST : 48Hr PER SAE AS 1344 METHOD 1001.1 CEI 529  
 OPERATING TEMPERATURE:  
 WITH PLASTIC COLLETS: -40°C TO +80°C (-40°F TO +176°F)

MASS (g)	VOLUME (mm <sup>3</sup> )
25.4	4652

NOTES:

1 RED DOT.

MATERIAL:

OUTER SHELL & BACK NUT : } BRASS  
 LATCHING SLEEVE }  
 HALF BUSHES : }

COLLET : RUBBER

FINISH:

OUTER SHELL & BACK NUT : CHROME

OTHER BRASS PARTS : NICKEL

T TOOLS

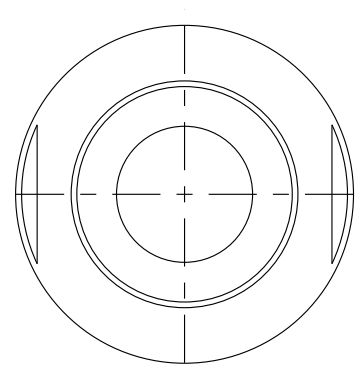

WIRE SIDE VIEW

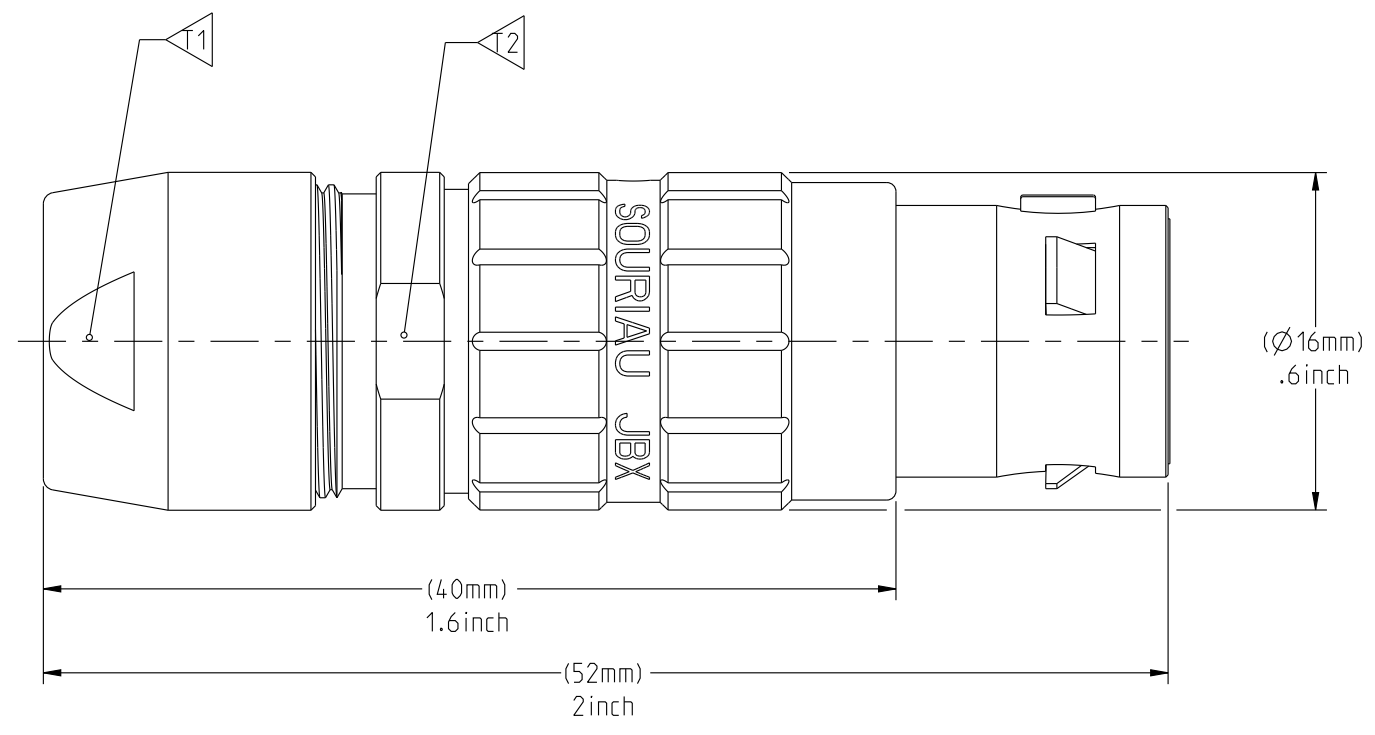

(ASSEMBLED VIEW FOR INFORMATION ONLY)

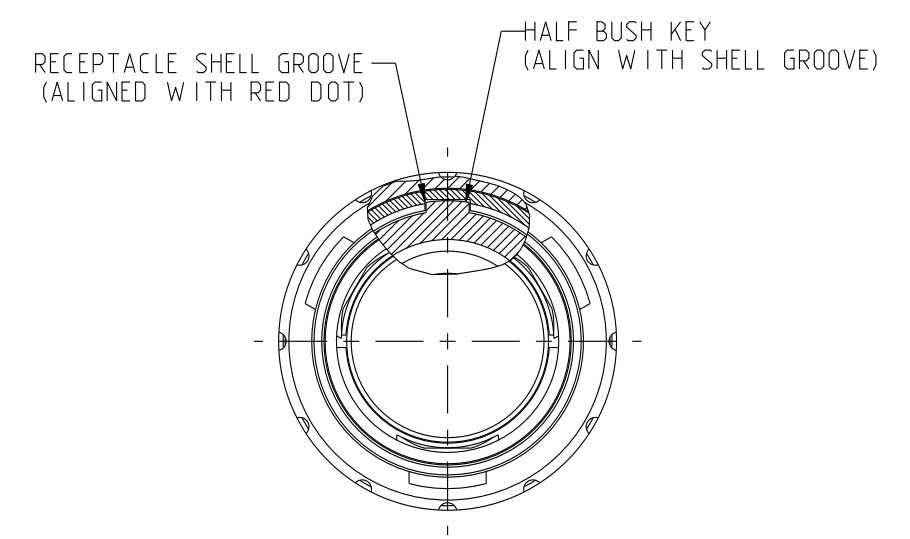

MATING SIDE VIEW

PART LIST	
ITEM NO.	DESCRIPTION
1	SLEEVE
2	HALF BUSH WITH WINDOW
3	HALF BUSH WITHOUT WINDOW
4	INSULATOR
5	Ø3.5-Ø9.7 CABLE COLLET (CHOOSE PER CABLE SIZE)
6	STANDARD BACK NUT
6a	BACK NUT FOR PROTECTIVE BOOT (OPTIONAL)

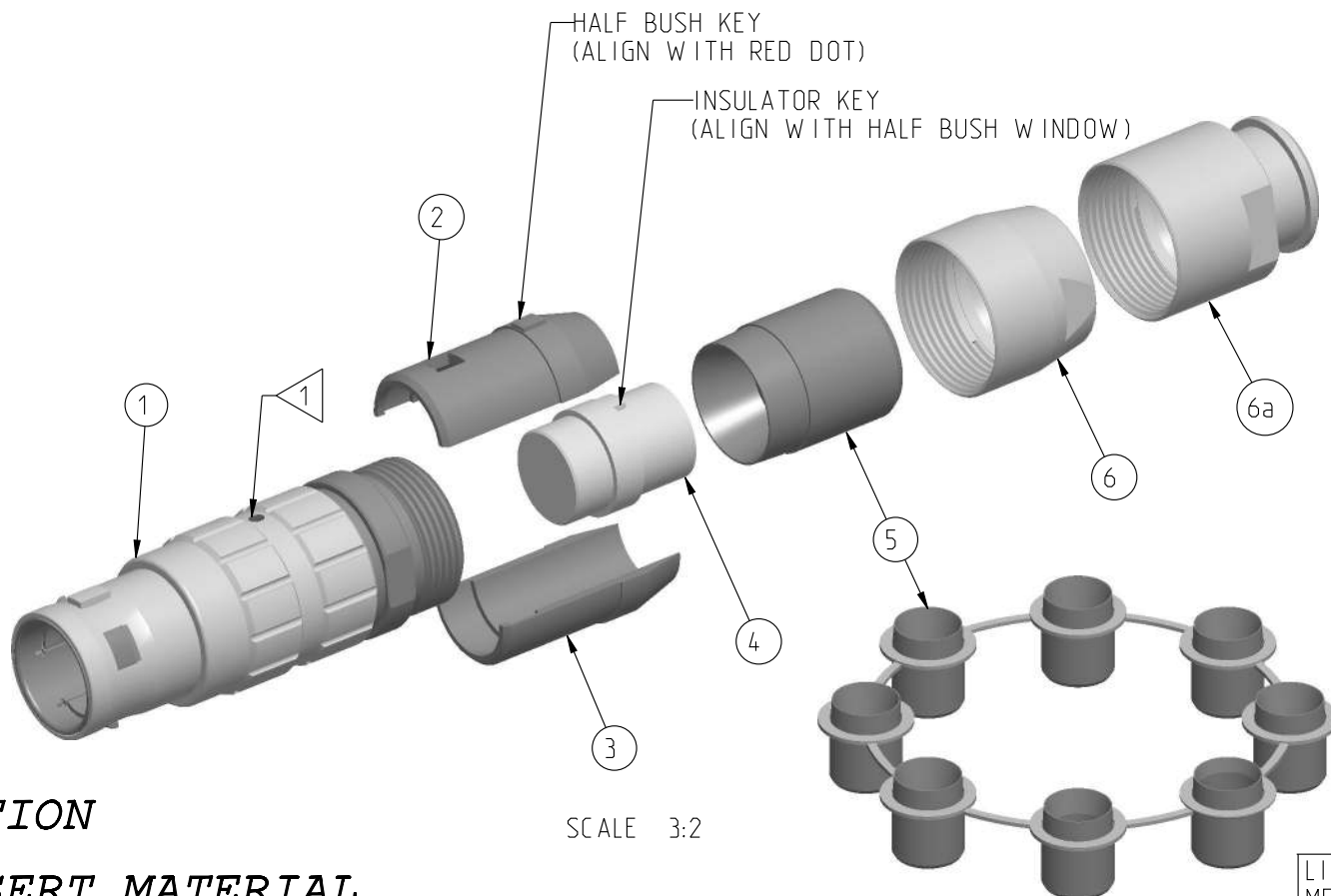

SCALE 3:2

COLLET SET SCALE 4:5

	TOOLS (JAW DIMENSION)	ADVISED TORQUE IN Nm
T1	13	1.5
T2	14	-

CATALOG NUMBER DESCRIPTION

JBX FH 2 XXXXXDXX

BASIC SERIES

SHELL TYPE

SHELL SIZE

KEYING

SEE INSULATOR DRAWING

OPTION

INSERT MATERIAL

COLLET OPTION

SURFACE PLATING

LINEAR MEASURE:  $\frac{mm}{(INCH)}$  mm (INCH)

THIRD ANGLE PROJECTION

TOLERANCES UNLESS OTHERWISE SPECIFIED

No. OF PLACES	mm [INCH]
WHOLE No.	±0.5 [±.02]
ONE PLACE	±0.2 [±.008]
TWO PLACES	±0.1 [±.004]

ANGLES ±1°

ORIGIN	COUNTRY	JURISDICTION	CLASSIFICATION
X	FR	Not listed	N/A
	US	EAR	ECCN =EAR99

These commodities, technology or software are exported from the United States in accordance with the Export Administration Regulations. Diversion contrary to U.S. law is prohibited.

A	RELEASED PER ECN 12280	TJS 06-10-15	EV 06-10-15
REV	DESCRIPTION	BY DATE	CHKD DATE

DRAWING TITLE: **JBX, SIZE 2, SEALED STRAIGHT PLUG**

CAT NO. **JBXFH2**

CAGE NO: 09922 SIZE: C

CUSTOMER: **SOURIAU**

www.souriau.com

INTERPRET THIS DRAWING IN ACCORDANCE WITH ASME Y14.5M - 1994.

APPROVAL: DRAWN: TJS 05-08-15, CHKD: EV 05-08-15, DSGN: EV 05-08-15, MFG: DH 05-08-15, QC: BB 05-08-15

DRAWING SCALE: 4:1

DRAWING NO. **JBXFH2C** REV **A**

1 OF 1

THIS DRAWING IS A CONTROLLED DOCUMENT FOR SOURIAU USA, INC. IT IS SUBJECT TO CHANGE WITHOUT NOTICE. CONTACT THE DOCUMENT CONTROL CENTER FOR THE LATEST REVISION.

THE INFORMATION CONTAINED IN THIS DRAWING IS CONFIDENTIAL AND MAY NOT BE DISCLOSED WITHOUT WRITTEN CONSENT FROM SOURIAU USA, INC.

DWG. NO.  
JBX2INSMSC

**MALE INSULATOR, SOLDER CONTACT**

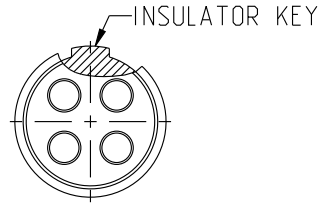
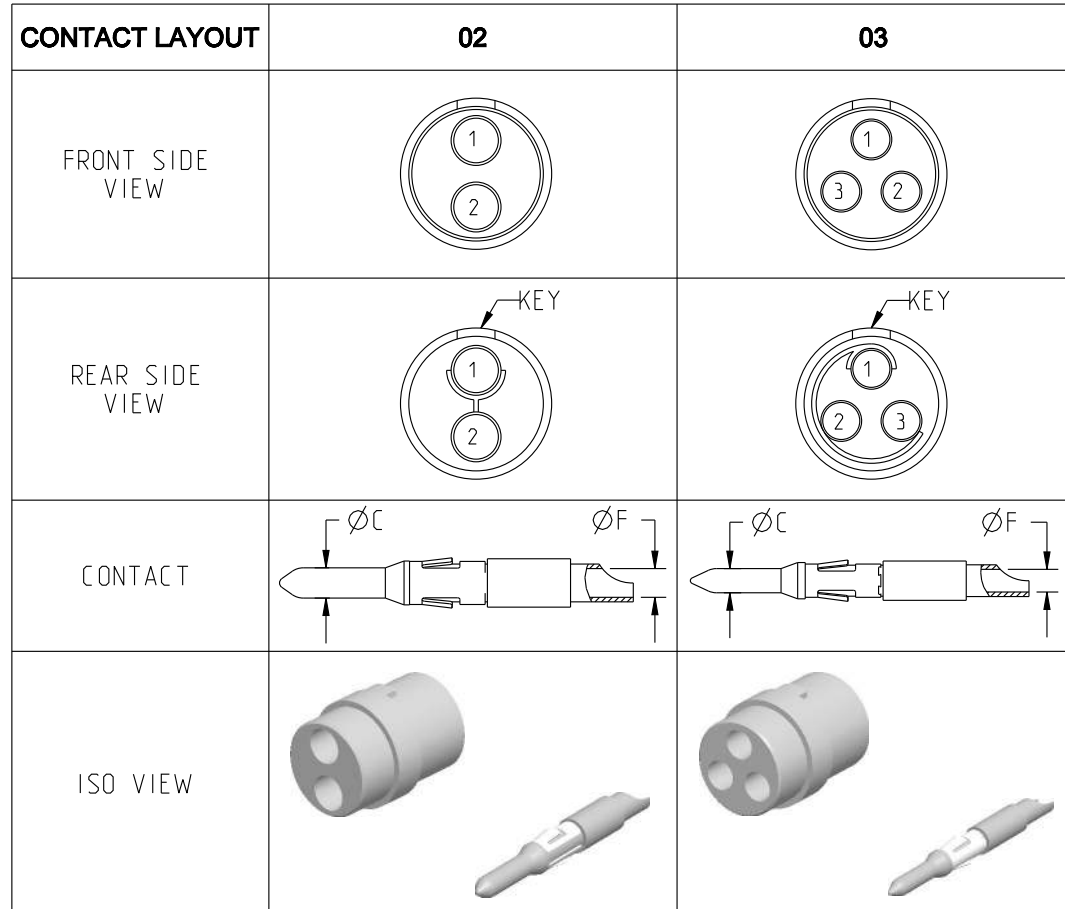

**CONTACT TYPE :** M (MALE)  
**CONTACT TERMINATION :** S (SOLDER)  
**MATERIAL :**  
 CONTACT: BRASS  
 CLIP: COPPER ALLOY  
 INSULATOR: PEEK  
**FINISH :**  
 CONTACTS: GOLD

**CATALOG NUMBER DESCRIPTION**

**JBXXX 2 XYYMS XXXX**

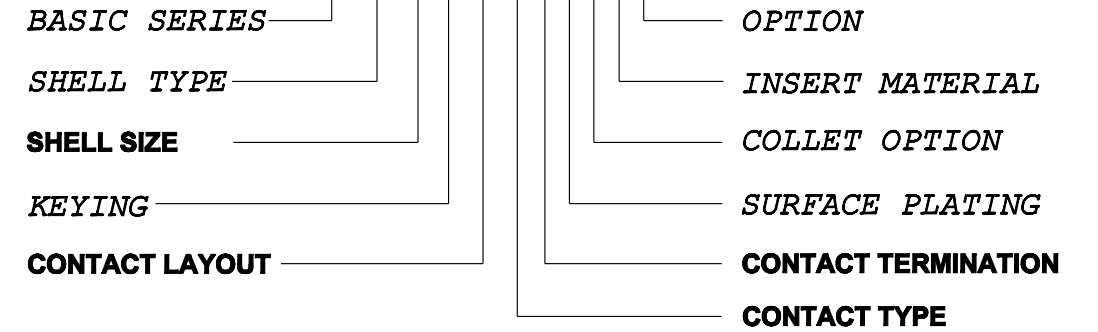

	02	03
CONTACT		
ØC	2	1.6
ØF	1.9	1.5
MAX. AWG	16	18
MAX. CURRENT RATING (A)	30	17
CONTACT RESISTANCE (mΩ)	2.5	2.5
INSULATOR		
NUMBER OF CAVITY	2	3
MAX. CURRENT RATING	30	17
TEST VOLTAGE (Vrms)	2100	1700
WORKING VOLTAGE (Vdc/Vrms)	1000/700	830/560

B	REVISED PER ECN 12286	RSK 06-10-15	EV 06-10-15
A	RELEASED PER ECN 12264	SKV 03-10-15	EV 03-10-15
REV	DESCRIPTION	BY DATE	CHKD DATE

THIS DRAWING IS A CONTROLLED DOCUMENT FOR SOURIAU USA, INC. IT IS SUBJECT TO CHANGE WITHOUT NOTIFICATION. CONTACT THE DOCUMENT CONTROL CENTER FOR THE LATEST REVISION.

THE INFORMATION CONTAINED IN THIS DRAWING IS CONFIDENTIAL AND MAY NOT BE DISCLOSED WITHOUT WRITTEN CONSENT FROM SOURIAU USA, INC.

B

A

LINEAR MEASURE:  $\frac{mm}{INCH}$  mm (INCH)

THIRD ANGLE PROJECTION

TOLERANCES UNLESS OTHERWISE SPECIFIED

No. OF PLACES	mm [INCH]
ONE PLACE	±3 [±.1]
TWO PLACES	±0.5 [±.02]
THREE PLACES	±0.25 [±.010]

ANGLES ±1°

ORIGIN	COUNTRY	JURISDICTION	CLASSIFICATION
X	FR	Not listed	N/A
	US	EAR	ECCN =EAR99

These commodities, technology or software are exported from the United States in accordance with the Export Administration Regulations. Diversion contrary to U.S. law is prohibited

DRAWING TITLE  
**JBX, SIZE 2, MALE INSULATOR, SOLDER CONTACT**

CAT NO. **JBX2INSMS**

CAGE NO: 09922    SIZE: B

**CUSTOMER**

**SOURIAU**

WWW.SOURIAU.COM

INTERPRET THIS DRAWING IN ACCORDANCE WITH ASME Y14.5M - 1994.

APPROVAL	DRAWN: SKV	02-02-15
	CHKD : EV	02-02-15
	DSGN : EV	02-02-15
	MFG : DH	02-02-15
	QC : BB	02-02-15
	DRAWING SCALE: NA	
	DRAWING NO.	REV
	JBX2INSMSC	B
	1 OF 3	

THIS DRAWING IS A CONTROLLED DOCUMENT FOR SOURIAU USA, INC. IT IS SUBJECT TO CHANGE WITHOUT NOTIFICATION. CONTACT THE DOCUMENT CONTROL CENTER FOR THE LATEST REVISION.

THE INFORMATION CONTAINED IN THIS DRAWING IS CONFIDENTIAL AND MAY NOT BE DISCLOSED WITHOUT WRITTEN CONSENT FROM SOURIAU USA, INC.

DWG. NO.  
JBX2INSMSC

	2				1		
CONTACT LAYOUT	04	05	06	07	08	10	
FRONT SIDE VIEW							
REAR SIDE VIEW							
CONTACT							
ISO VIEW							
CONTACT	ØC	1.3	1.3	1.3	0.9	0.9	
	ØF	1.1	1.1	1.1	0.8	0.8	
	MAX. AWG	20	20	20	24	24	
	MAX. CURRENT RATING (A)	15	15	15	10	10	
INSULATOR	CONTACT RESISTANCE (mΩ)	3	3	3	3.5	3.5	
	NUMBER OF CAVITY	4	5	6	7	10	
	MAX. CURRENT RATING	15	14	12	11	8	
	TEST VOLTAGE (Vrms)	2400	1900	1900	1500	1700	
WORKING VOLTAGE (Vdc/Vrms)	1000/700	900/630	900/630	730/500	830/560	830/560	

DRAWING TITLE  
**JBX, SIZE 2, MALE INSULATOR, SOLDER CONTACT**

CAT NO. **JBX2INSMS**

CAGE NO: 09922      SIZE: B

CUSTOMER

SOURIAU

WWW.SOURIAU.COM

INTERPRET THIS DRAWING IN ACCORDANCE WITH ASME Y14.5M - 1994.

APPROVAL	DRAWN: SKV	02-02-15
	CHKD : EV	02-02-15
	DSGN : EV	02-02-15
	MFG : DH	02-02-15
	QC : BB	02-02-15
DRAWING SCALE: NA		
DRAWING NO. JBX2INSMSC		REV B
		2 OF 3

ORIGIN	COUNTRY	JURISDICTION	CLASSIFICATION
X	FR	Not listed	N/A
	US	EAR	ECCN =EAR99

These commodities, technology or software are exported from the United States in accordance with the Export Administration Regulations. Diversion contrary to U.S. law is prohibited.

LINEAR MEASURE: mm (INCH) mm (INCH)

THIRD ANGLE PROJECTION

TOLERANCES UNLESS OTHERWISE SPECIFIED

No. OF PLACES	mm [INCH]
ONE PLACE	±3 [±.1]
TWO PLACES	±0.5 [±.02]
THREE PLACES	±0.25 [±.010]

ANGLES ±1°

B

A

DWG. NO.  
JBX2INSMSC

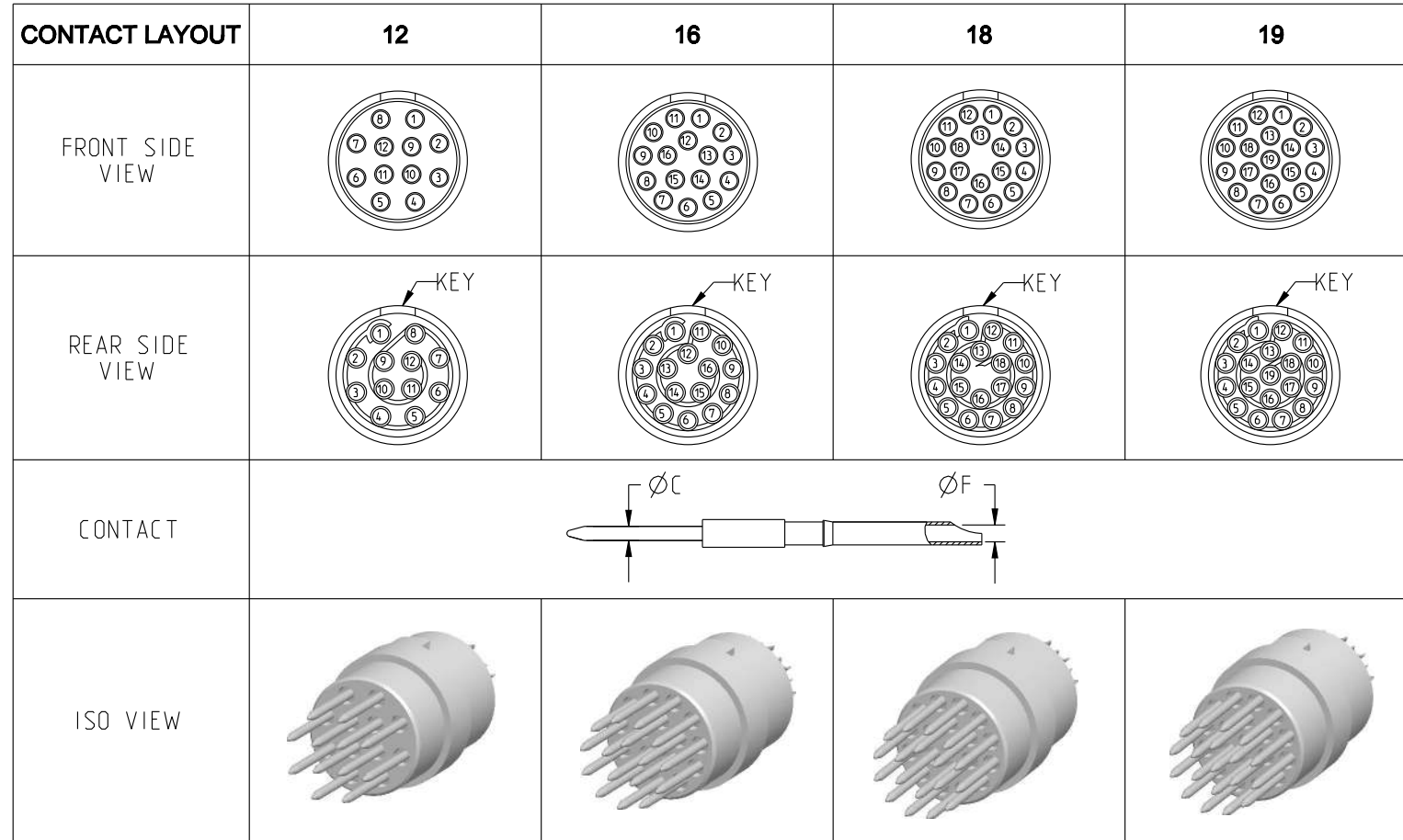

CONTACT	ØC	0.7	0.7	0.7	0.7
	ØF	0.81	0.81	0.81	0.81
	MAX. AWG	22	22	22	22
	MAX. CURRENT RATING (A)	7	7	7	7
	CONTACT RESISTANCE (mΩ)	5	5	5	5
INSULATOR	NUMBER OF CAVITY	12	16	18	19
	MAX. CURRENT RATING	7	6	5.5	5
	TEST VOLTAGE (Vrms)	1700	1500	1400	1400
	WORKING VOLTAGE (Vdc/Vrms)	830/560	730/500	660/460	660/460

THIS DRAWING IS A CONTROLLED DOCUMENT FOR SOURIAU USA, INC. IT IS SUBJECT TO CHANGE WITHOUT NOTIFICATION. CONTACT THE DOCUMENT CONTROL CENTER FOR THE LATEST REVISION.

THE INFORMATION CONTAINED IN THIS DRAWING IS CONFIDENTIAL AND MAY NOT BE DISCLOSED WITHOUT WRITTEN CONSENT FROM SOURIAU USA, INC.

B

A

DRAWING TITLE  
**JBX, SIZE 2, MALE INSULATOR, SOLDER CONTACT**

CAT NO. **JBX2INSMS**

CAGE NO: 09922      SIZE: B

<b>CUSTOMER</b>	<b>SOURIAU</b>	APPROVAL	DRAWN: SKV 02-02-15
		CHKD : EV 02-02-15	
INTERPRET THIS DRAWING IN ACCORDANCE WITH ASME Y14.5M - 1994.	<b>WWW.SOURIAU.COM</b>	DSGN : EV 02-02-15	DRAWING SCALE: NA
		MFG : DH 02-02-15	DRAWING NO. REV
		QC : BB 02-02-15	JBX2INSMSC B
			3 OF 3

LINEAR MEASURE:  $\frac{mm}{INCH}$  mm (INCH)

THIRD ANGLE PROJECTION

TOLERANCES UNLESS OTHERWISE SPECIFIED

No. OF PLACES	mm [INCH]
ONE PLACE	±3 [±.1]
TWO PLACES	±0.5 [±.02]
THREE PLACES	±0.25 [±.010]

ANGLES ±1°

ORIGIN	COUNTRY	JURISDICTION	CLASSIFICATION
X	FR	Not listed	N/A
	US	EAR	ECCN =EAR99

These commodities, technology or software are exported from the United States in accordance with the Export Administration Regulations. Diversion contrary to U.S. law is prohibited