

54ACT16652, 74ACT16652 16-BIT TRANSCEIVERS AND REGISTERS WITH 3-STATE OUTPUTS

SCAS128C – MARCH 1990 – REVISED APRIL 1996

- Members of the Texas Instruments *Widebus™* Family
- Inputs Are TTL-Voltage Compatible
- Independent Registers and Enables for A and B Buses
- Multiplexed Real-Time and Stored Data
- Flow-Through Architecture Optimizes PCB Layout
- Distributed V_{CC} and GND Pin Configuration Minimizes High-Speed Switching Noise
- *EPIC™* (Enhanced-Performance Implanted CMOS) 1- μ m Process
- 500-mA Typical Latch-Up Immunity at 125°C
- Package Options Include Plastic 300-mil Shrink Small-Outline (DL) Packages Using 25-mil Center-to-Center Pin Spacings and 380-mil Fine-Pitch Ceramic Flat (WD) Packages Using 25-mil Center-to-Center Spacings

description

The 'ACT16652 are 16-bit bus transceivers consisting of D-type flip-flops and control circuitry arranged for multiplexed transmission of data directly from the data bus or from the internal storage registers. The devices can be used as two 8-bit transceivers or one 16-bit transceiver.

Complementary output-enable (OEAB and \overline{OEBA}) inputs are provided to control the transceiver functions. Select-control (SAB and SBA) inputs are provided to select whether real-time or stored data is transferred. A low input level selects real-time data, and a high input level selects stored data. The circuitry used for select control eliminates the typical decoding glitch that occurs in a multiplexer during the transition between stored and real-time data. Figure 1 illustrates the four fundamental bus-management functions that can be performed with the 'ACT16652.

54ACT16652 . . . WD PACKAGE
74ACT16652 . . . DL PACKAGE
(TOP VIEW)

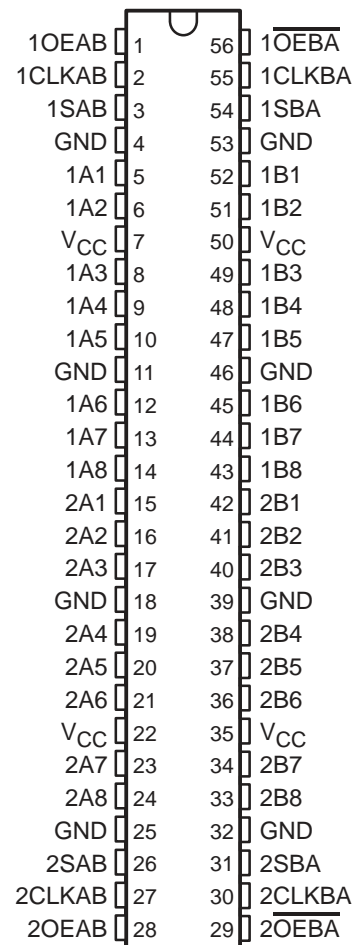

Please be aware that an important notice concerning availability, standard warranty, and use in critical applications of Texas Instruments semiconductor products and disclaimers thereto appears at the end of this data sheet.

EPIC and Widebus are trademarks of Texas Instruments Incorporated.

UNLESS OTHERWISE NOTED this document contains PRODUCTION DATA information current as of publication date. Products conform to specifications per the terms of Texas Instruments standard warranty. Production processing does not necessarily include testing of all parameters.



POST OFFICE BOX 655303 • DALLAS, TEXAS 75265

Copyright © 1996, Texas Instruments Incorporated

54ACT16652, 74ACT16652
16-BIT TRANSCEIVERS AND REGISTERS
WITH 3-STATE OUTPUTS

SCAS128C – MARCH 1990 – REVISED APRIL 1996

description (continued)

Data on the A or B bus, or both, can be stored in the internal D flip-flops by low-to-high transitions at the appropriate clock (CLKAB or CLKBA) inputs, regardless of the levels on the select-control or output-enable inputs. When SAB and SBA are in the real-time transfer mode, it is also possible to store data without using the internal D-type flip-flops by simultaneously enabling OEAB and OEBA. In this configuration, each output reinforces its input. Thus, when all other data sources to the two sets of bus lines are at high impedance, each set of bus lines remains at its last state.

The 74ACT16652 is packaged in TI's shrink small-outline package, which provides twice the I/O pin count and functionality of standard small-outline packages in the same printed-circuit-board area.

The 54ACT16652 is characterized for operation over the full military temperature range of -55°C to 125°C. The 74ACT16652 is characterized for operation from -40°C to 85°C.

FUNCTION TABLE

| INPUTS | | | | | | DATA I/O† | | OPERATION OR FUNCTION |
|--------|------|-------|-------|-----|-----|--------------|--------------|---|
| OEAB | OEBA | CLKAB | CLKBA | SAB | SBA | A1-A8 | B1-B8 | |
| L | H | L | L | X | X | Input | Input | Isolation |
| L | H | ↑ | ↑ | X | X | Input | Input | Store A and B data |
| X | H | ↑ | L | X | X | Input | Unspecified‡ | Store A, hold B |
| H | H | ↑ | ↑ | X‡ | X | Input | Output | Store A in both registers |
| L | X | L | ↑ | X | X | Unspecified‡ | Input | Hold A, store B |
| L | L | ↑ | ↑ | X | X‡ | Output | Input | Store B in both registers |
| L | L | X | X | X | L | Output | Input | Real-time B data to A bus |
| L | L | X | L | X | H | Output | Input | Stored B data to A bus |
| H | H | X | X | L | X | Input | Output | Real-time A data to B bus |
| H | H | L | X | H | X | Input | Output | Stored A data to B bus |
| H | L | L | L | H | H | Output | Output | Stored A data to B bus and stored B data to A bus |

† The data-output functions may be enabled or disabled by a variety of level combinations at OEAB or OEBA. Data-input functions are always enabled; i.e., data at the bus terminals is stored on every low-to-high transition of the clock inputs.

‡ Select control = L; clocks can occur simultaneously.

Select control = H; clocks must be staggered to load both registers.



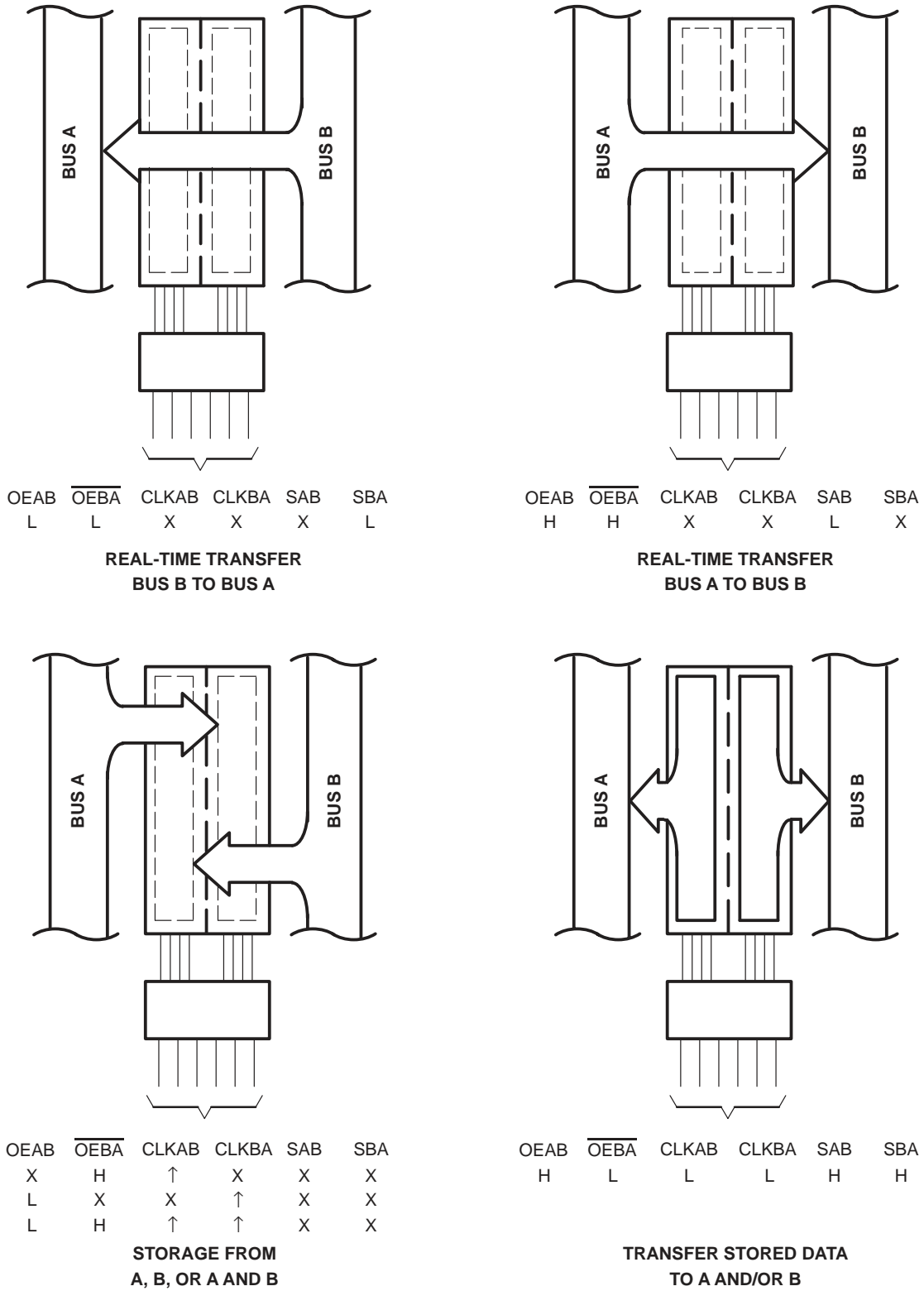
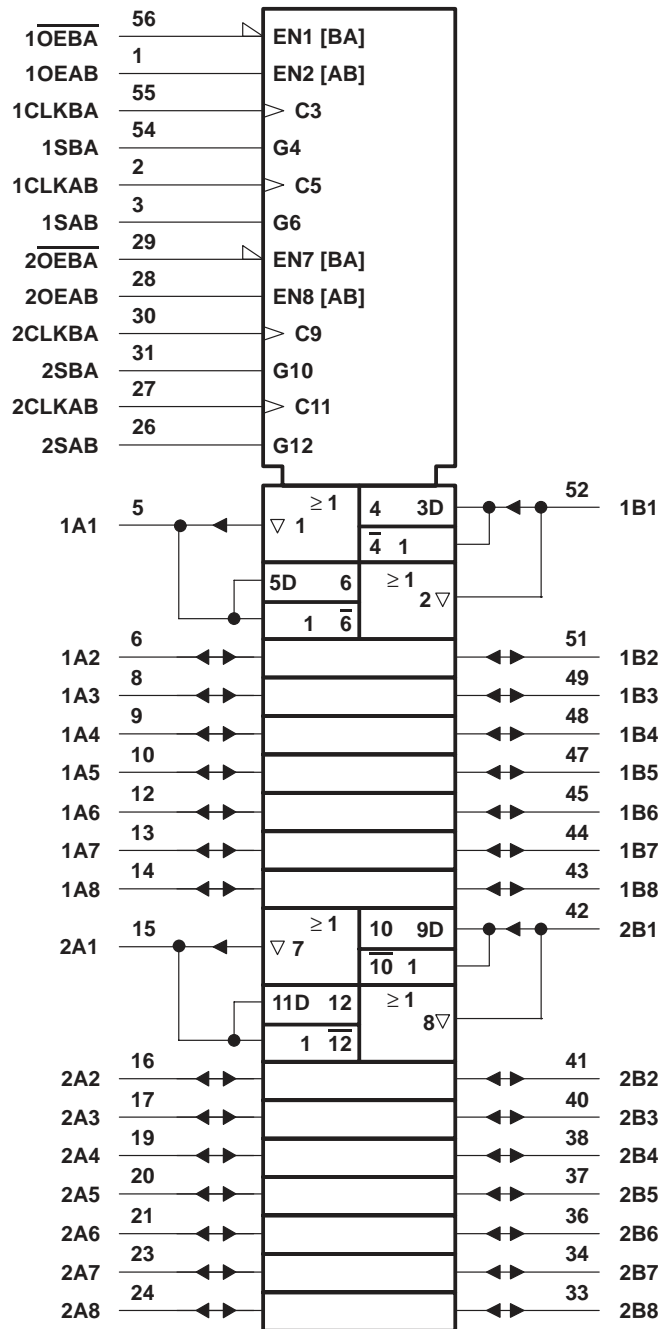

Figure 1. Bus-Management Functions

54ACT16652, 74ACT16652 16-BIT TRANSCEIVERS AND REGISTERS WITH 3-STATE OUTPUTS

SCAS128C – MARCH 1990 – REVISED APRIL 1996

logic symbol†



† This symbol is in accordance with ANSI/IEEE Std 91-1984 and IEC Publication 617-12.

54ACT16652, 74ACT16652
 16-BIT TRANSCEIVERS AND REGISTERS
 WITH 3-STATE OUTPUTS

SCAS128C – MARCH 1990 – REVISED APRIL 1996

logic diagram (positive logic)

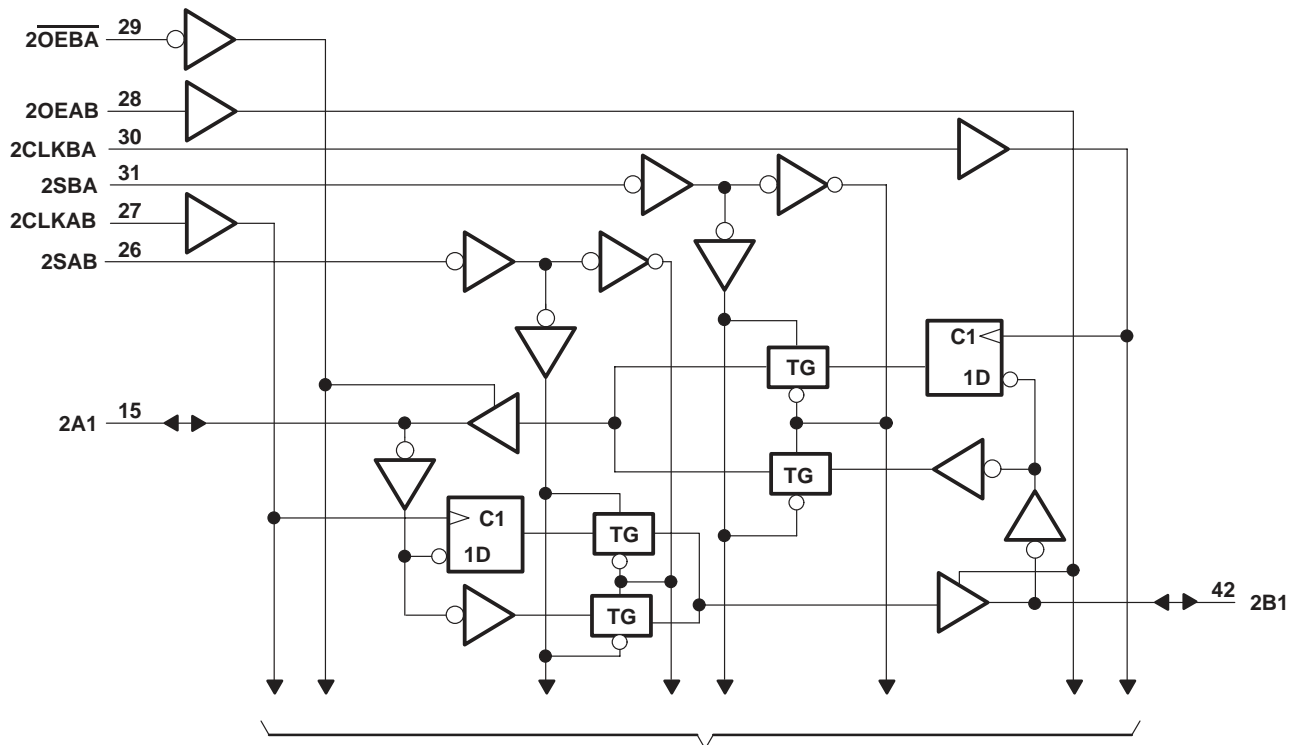
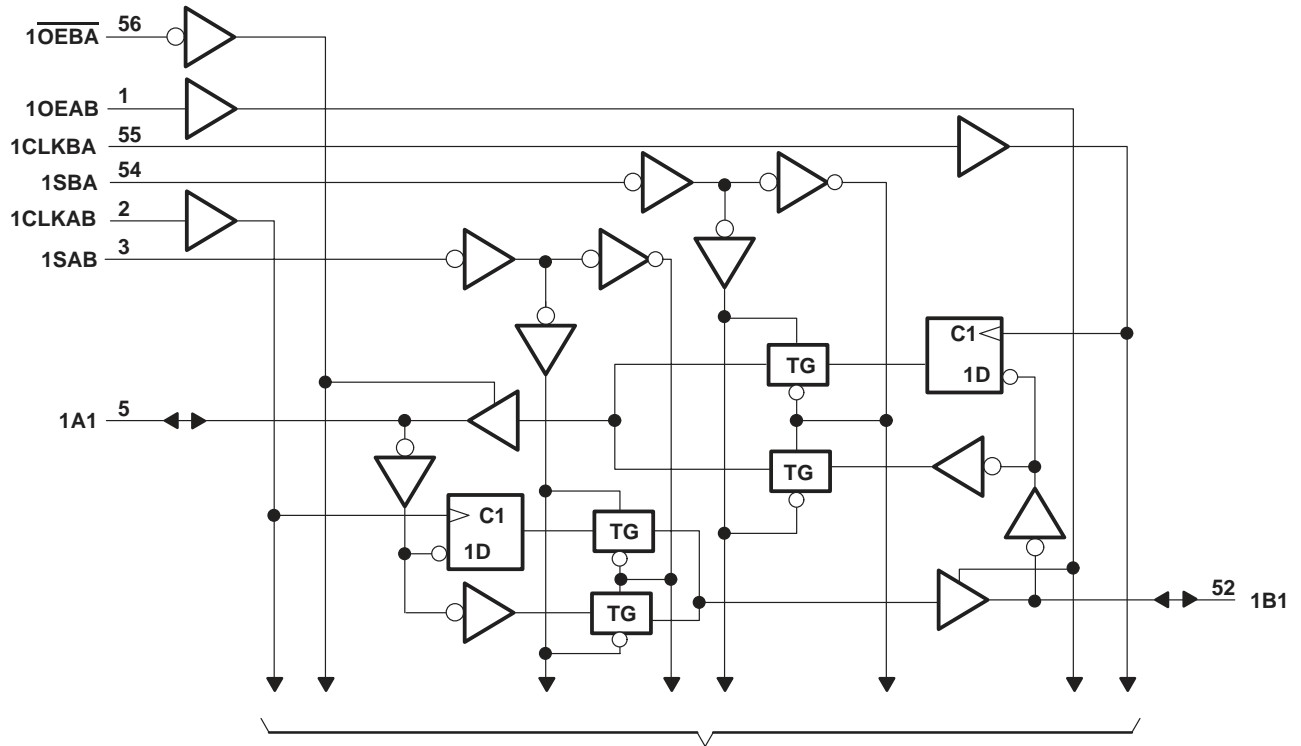

54ACT16652, 74ACT16652 16-BIT TRANSCEIVERS AND REGISTERS WITH 3-STATE OUTPUTS

SCAS128C – MARCH 1990 – REVISED APRIL 1996

absolute maximum ratings over operating free-air temperature range (unless otherwise noted)†

| | |
|---|--|
| Supply voltage range, V_{CC} | -0.5 V to 7 V |
| Input voltage range, V_I (see Note 1) | -0.5 V to $V_{CC} + 0.5$ V |
| Output voltage range, V_O (see Note 1) | -0.5 V to $V_{CC} + 0.5$ V |
| Input clamp current, I_{IK} ($V_I < 0$ or $V_I > V_{CC}$) | ± 20 mA |
| Output clamp current, I_{OK} ($V_O < 0$ or $V_O > V_{CC}$) | ± 50 mA |
| Continuous output current, I_O ($V_O = 0$ to V_{CC}) | ± 50 mA |
| Continuous current through V_{CC} or GND | ± 400 mA |
| Maximum package power dissipation at $T_A = 55^\circ\text{C}$ (in still air) (see Note 2): DL package | 1.4 W |
| Storage temperature range, T_{stg} | -65°C to 150°C |

† Stresses beyond those listed under “absolute maximum ratings” may cause permanent damage to the device. These are stress ratings only, and functional operation of the device at these or any other conditions beyond those indicated under “recommended operating conditions” is not implied. Exposure to absolute-maximum-rated conditions for extended periods may affect device reliability.

- NOTES: 1. The input and output voltage ratings may be exceeded if the input and output current ratings are observed.
2. The maximum package power dissipation is calculated using a junction temperature of 150°C and a board trace length of 750 mils.

recommended operating conditions (see Note 3)

| | 54ACT16652 | | | 74ACT16652 | | | UNIT |
|--|------------|-----|----------|------------|-----|----------|------------------|
| | MIN | NOM | MAX | MIN | NOM | MAX | |
| V_{CC} Supply voltage | 4.5 | 5 | 5.5 | 4.5 | 5 | 5.5 | V |
| V_{IH} High-level input voltage | 2 | | | 2 | | | V |
| V_{IL} Low-level input voltage | | | 0.8 | | | 0.8 | V |
| V_I Input voltage | 0 | | V_{CC} | 0 | | V_{CC} | V |
| V_O Output voltage | 0 | | V_{CC} | 0 | | V_{CC} | V |
| I_{OH} High-level output current | | | -24 | | | -24 | mA |
| I_{OL} Low-level output current | | | 24 | | | 24 | mA |
| $\Delta t/\Delta v$ Input transition rise or fall rate | 0 | | 10 | 0 | | 10 | ns/V |
| T_A Operating free-air temperature | -55 | | 125 | -40 | | 85 | $^\circ\text{C}$ |

NOTE 3: Unused pins (input or I/O) must be held high or low to prevent them from floating.

54ACT16652, 74ACT16652
16-BIT TRANSCEIVERS AND REGISTERS
WITH 3-STATE OUTPUTS

SCAS128C – MARCH 1990 – REVISED APRIL 1996

electrical characteristics over recommended operating free-air temperature range (unless otherwise noted)

| PARAMETER | TEST CONDITIONS | V _{CC} | T _A = 25°C | | | 54ACT16652 | | 74ACT16652 | | UNIT |
|-------------------------------|---------------------------------------|---|-----------------------|-----|------|------------|------|------------|-----|------|
| | | | MIN | TYP | MAX | MIN | MAX | MIN | MAX | |
| V _{OH} | I _{OH} = -50 μA | 4.5 V | 4.4 | | | 4.4 | | 4.4 | V | |
| | | 5.5 V | 5.4 | | | 5.4 | | 5.4 | | |
| | I _{OH} = -24 mA | 4.5 V | 3.94 | | | 3.8 | | 3.8 | | |
| | | 5.5 V | 4.94 | | | 4.8 | | 4.8 | | |
| | I _{OH} = -75 mA [†] | 5.5 V | | | | 3.85 | | 3.85 | | |
| V _{OL} | I _{OL} = 50 μA | 4.5 V | | | 0.1 | | 0.1 | 0.1 | V | |
| | | 5.5 V | | | 0.1 | | 0.1 | 0.1 | | |
| | I _{OL} = 24 mA | 4.5 V | | | 0.36 | | 0.44 | 0.44 | | |
| | | 5.5 V | | | 0.36 | | 0.44 | 0.44 | | |
| | I _{OL} = 75 mA [†] | 5.5 V | | | | 1.65 | | 1.65 | | |
| I _I | Control inputs | V _I = V _{CC} or GND | 5.5 V | | | ±0.1 | | ±1 | μA | |
| I _{OZ} [‡] | A or B ports | V _O = V _{CC} or GND | 5.5 V | | | ±0.5 | | ±5 | μA | |
| I _{CC} | | V _I = V _{CC} or GND, I _O = 0 | 5.5 V | | | 8 | | 80 | μA | |
| ΔI _{CC} [§] | | One input at 3.4 V, Other inputs at V _{CC} or GND | 5.5 V | | | 0.9 | | 1 | mA | |
| C _i | Control inputs | V _I = V _{CC} or GND | 5 V | | | 4 | | | pF | |
| C _{io} | A or B ports | V _O = V _{CC} or GND | 5 V | | | 12 | | | pF | |

[†] Not more than one output should be tested at a time, and the duration of the test should not exceed 10 ms.

[‡] For I/O ports, the parameter I_{OZ} includes the input leakage current.

[§] This is the increase in supply current for each input that is at one of the specified TTL voltage levels rather than 0 V or V_{CC}.

timing requirements over recommended operating free-air temperature range, V_{CC} = 5 V ± 0.5 V (unless otherwise noted) (see Figure 1)

| | | T _A = 25°C | | 54ACT16652 | | 74ACT16652 | | UNIT |
|--------------------|--|-----------------------|-----|------------|-----|------------|-----|------|
| | | MIN | MAX | MIN | MAX | MIN | MAX | |
| f _{clock} | Clock frequency | 0 | 90 | 0 | 90 | 0 | 90 | MHz |
| t _w | Pulse duration, CLKAB or CLKBA high or low | 5.5 | | 5.5 | | 5.5 | | ns |
| t _{su} | Setup time, A before CLKAB [↑] or B before CLKBA [↑] | 4.5 | | 4.5 | | 4.5 | | ns |
| t _h | Hold time, A after CLKAB [↑] or B after CLKBA [↑] | 1 | | 1 | | 1 | | ns |

PRODUCT PREVIEW information concerns products in the formative or design phase of development. Characteristic data and other specifications are design goals. Texas Instruments reserves the right to change or discontinue these products without notice.



POST OFFICE BOX 655303 • DALLAS, TEXAS 75265

54ACT16652, 74ACT16652
16-BIT TRANSCEIVERS AND REGISTERS
WITH 3-STATE OUTPUTS

SCAS128C – MARCH 1990 – REVISED APRIL 1996

**switching characteristics over recommended operating free-air temperature range,
 $V_{CC} = 5\text{ V} \pm 0.5\text{ V}$ (unless otherwise noted) (see Figure 2)**

| PARAMETER | FROM (INPUT) | TO (OUTPUT) | $T_A = 25^\circ\text{C}$ | | | 54ACT16652 | | 74ACT16652 | | UNIT |
|------------------|----------------------------------|-------------|--------------------------|------|------|------------|------|------------|------|------|
| | | | MIN | TYP | MAX | MIN | MAX | MIN | MAX | |
| f_{max} | | | 90 | | | 90 | | 90 | | MHz |
| t_{PLH} | A or B | B or A | 3.7 | 7.2 | 9.4 | 3.7 | 10.5 | 3.7 | 10.5 | ns |
| t_{PHL} | | | 3 | 8.1 | 10.5 | 3 | 11.6 | 3 | 11.6 | |
| t_{PLH} | CLKBA or CLKAB | A or B | 4.5 | 8.7 | 11.2 | 4.5 | 12.3 | 4.5 | 12.3 | ns |
| t_{PHL} | | | 4.9 | 8.9 | 11.3 | 4.9 | 12.3 | 4.9 | 12.3 | |
| t_{PLH} | SBA or SAB (with A or B high) | A or B | 4.9 | 10.4 | 14.1 | 4.9 | 16 | 4.9 | 16 | ns |
| t_{PHL} | | | 4.6 | 8.4 | 10.6 | 4.6 | 11.7 | 4.6 | 11.7 | |
| t_{PLH} | SBA or SAB (with A or B low) | A or B | 3.9 | 7.8 | 10 | 3.9 | 11.2 | 3.9 | 11.2 | ns |
| t_{PHL} | | | 5.6 | 12.3 | 14.9 | 5.6 | 16.9 | 5.6 | 16.9 | |
| t_{PZH} | $\overline{\text{OEBA}}$ | A | 3 | 8.1 | 10.5 | 3 | 11.7 | 3 | 11.7 | ns |
| t_{PZL} | | | 3.9 | 9.4 | 12 | 3.9 | 13.4 | 3.9 | 13.4 | |
| t_{PHZ} | $\overline{\text{OEBA}}$ | A | 5.3 | 7.4 | 8.9 | 5.3 | 9.5 | 5.3 | 9.5 | ns |
| t_{PLZ} | | | 4.8 | 6.8 | 8.6 | 4.8 | 9.2 | 4.8 | 9.2 | |
| t_{PZH} | OEAB | B | 4.1 | 7.7 | 9.8 | 4.1 | 10.8 | 4.1 | 10.8 | ns |
| t_{PZL} | | | 5 | 9 | 11 | 5 | 12.4 | 5 | 12.4 | |
| t_{PHZ} | OEAB | B | 4.4 | 8.1 | 10.1 | 4.4 | 10.5 | 4.4 | 10.5 | ns |
| t_{PLZ} | | | 4.3 | 7.7 | 9.7 | 4.3 | 9.9 | 4.3 | 9.9 | |

operating characteristics, $V_{CC} = 5\text{ V}$, $T_A = 25^\circ\text{C}$

| PARAMETER | | TEST CONDITIONS | TYP | UNIT |
|-----------------|---|------------------|-----|------|
| C_{pd} | Power dissipation capacitance per transceiver | Outputs enabled | 57 | pF |
| | | Outputs disabled | 13 | |

PRODUCT PREVIEW information concerns products in the formative or design phase of development. Characteristic data and other specifications are design goals. Texas Instruments reserves the right to change or discontinue these products without notice.



POST OFFICE BOX 655303 • DALLAS, TEXAS 75265

PARAMETER MEASUREMENT INFORMATION

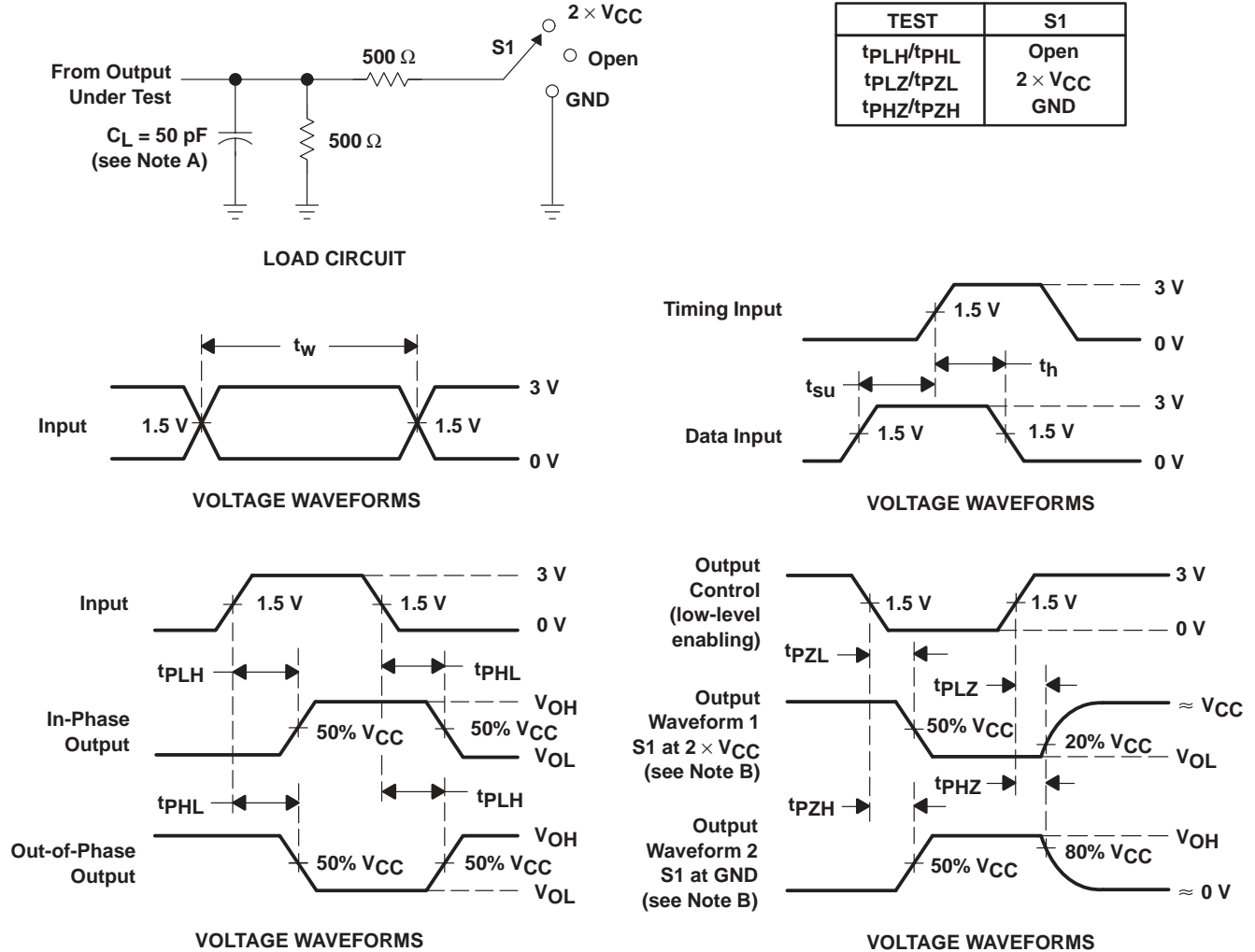

- NOTES: A. C_L includes probe and jig capacitance.
 B. Waveform 1 is for an output with internal conditions such that the output is low except when disabled by the output control. Waveform 2 is for an output with internal conditions such that the output is high except when disabled by the output control.
 C. All input pulses are supplied by generators having the following characteristics: $PRR \leq 1 \text{ MHz}$, $Z_O = 50 \Omega$, $t_r = 3 \text{ ns}$, $t_f = 3 \text{ ns}$.
 D. The outputs are measured one at a time with one input transition per measurement.

Figure 2. Load Circuit and Voltage Waveforms

PACKAGING INFORMATION

| Orderable Device | Status (1) | Package Type | Package Drawing | Pins | Package Qty | Eco Plan (2) | Lead finish/ Ball material (6) | MSL Peak Temp (3) | Op Temp (°C) | Device Marking (4/5) | Samples |
|------------------|---------------|--------------|-----------------|------|-------------|-----------------|--------------------------------------|----------------------|--------------|-------------------------|---------|
| 74ACT16652DL | LIFEBUY | SSOP | DL | 56 | 20 | RoHS & Green | NIPDAU | Level-1-260C-UNLIM | -40 to 85 | ACT16652 | |
| 74ACT16652DLR | ACTIVE | SSOP | DL | 56 | 1000 | RoHS & Green | NIPDAU | Level-1-260C-UNLIM | -40 to 85 | ACT16652 | Samples |

(1) The marketing status values are defined as follows:

ACTIVE: Product device recommended for new designs.

LIFEBUY: TI has announced that the device will be discontinued, and a lifetime-buy period is in effect.

NRND: Not recommended for new designs. Device is in production to support existing customers, but TI does not recommend using this part in a new design.

PREVIEW: Device has been announced but is not in production. Samples may or may not be available.

OBSELETE: TI has discontinued the production of the device.

(2) **RoHS:** TI defines "RoHS" to mean semiconductor products that are compliant with the current EU RoHS requirements for all 10 RoHS substances, including the requirement that RoHS substance do not exceed 0.1% by weight in homogeneous materials. Where designed to be soldered at high temperatures, "RoHS" products are suitable for use in specified lead-free processes. TI may reference these types of products as "Pb-Free".

RoHS Exempt: TI defines "RoHS Exempt" to mean products that contain lead but are compliant with EU RoHS pursuant to a specific EU RoHS exemption.

Green: TI defines "Green" to mean the content of Chlorine (Cl) and Bromine (Br) based flame retardants meet JS709B low halogen requirements of <=1000ppm threshold. Antimony trioxide based flame retardants must also meet the <=1000ppm threshold requirement.

(3) MSL, Peak Temp. - The Moisture Sensitivity Level rating according to the JEDEC industry standard classifications, and peak solder temperature.

(4) There may be additional marking, which relates to the logo, the lot trace code information, or the environmental category on the device.

(5) Multiple Device Markings will be inside parentheses. Only one Device Marking contained in parentheses and separated by a "~" will appear on a device. If a line is indented then it is a continuation of the previous line and the two combined represent the entire Device Marking for that device.

(6) Lead finish/Ball material - Orderable Devices may have multiple material finish options. Finish options are separated by a vertical ruled line. Lead finish/Ball material values may wrap to two lines if the finish value exceeds the maximum column width.

Important Information and Disclaimer:The information provided on this page represents TI's knowledge and belief as of the date that it is provided. TI bases its knowledge and belief on information provided by third parties, and makes no representation or warranty as to the accuracy of such information. Efforts are underway to better integrate information from third parties. TI has taken and continues to take reasonable steps to provide representative and accurate information but may not have conducted destructive testing or chemical analysis on incoming materials and chemicals. TI and TI suppliers consider certain information to be proprietary, and thus CAS numbers and other limited information may not be available for release.

In no event shall TI's liability arising out of such information exceed the total purchase price of the TI part(s) at issue in this document sold by TI to Customer on an annual basis.

TAPE AND REEL INFORMATION

QUADRANT ASSIGNMENTS FOR PIN 1 ORIENTATION IN TAPE

*All dimensions are nominal

| Device | Package Type | Package Drawing | Pins | SPQ | Reel Diameter (mm) | Reel Width W1 (mm) | A0 (mm) | B0 (mm) | K0 (mm) | P1 (mm) | W (mm) | Pin1 Quadrant |
|---------------|--------------|-----------------|------|------|--------------------|--------------------|---------|---------|---------|---------|--------|---------------|
| 74ACT16652DLR | SSOP | DL | 56 | 1000 | 330.0 | 32.4 | 11.35 | 18.67 | 3.1 | 16.0 | 32.0 | Q1 |

TAPE AND REEL BOX DIMENSIONS

*All dimensions are nominal

| Device | Package Type | Package Drawing | Pins | SPQ | Length (mm) | Width (mm) | Height (mm) |
|---------------|--------------|-----------------|------|------|-------------|------------|-------------|
| 74ACT16652DLR | SSOP | DL | 56 | 1000 | 367.0 | 367.0 | 55.0 |

TUBE

*All dimensions are nominal

| Device | Package Name | Package Type | Pins | SPQ | L (mm) | W (mm) | T (μm) | B (mm) |
|--------------|--------------|--------------|------|-----|--------|--------|--------|--------|
| 74ACT16652DL | DL | SSOP | 56 | 20 | 473.7 | 14.24 | 5110 | 7.87 |

IMPORTANT NOTICE AND DISCLAIMER

TI PROVIDES TECHNICAL AND RELIABILITY DATA (INCLUDING DATA SHEETS), DESIGN RESOURCES (INCLUDING REFERENCE DESIGNS), APPLICATION OR OTHER DESIGN ADVICE, WEB TOOLS, SAFETY INFORMATION, AND OTHER RESOURCES "AS IS" AND WITH ALL FAULTS, AND DISCLAIMS ALL WARRANTIES, EXPRESS AND IMPLIED, INCLUDING WITHOUT LIMITATION ANY IMPLIED WARRANTIES OF MERCHANTABILITY, FITNESS FOR A PARTICULAR PURPOSE OR NON-INFRINGEMENT OF THIRD PARTY INTELLECTUAL PROPERTY RIGHTS.

These resources are intended for skilled developers designing with TI products. You are solely responsible for (1) selecting the appropriate TI products for your application, (2) designing, validating and testing your application, and (3) ensuring your application meets applicable standards, and any other safety, security, regulatory or other requirements.

These resources are subject to change without notice. TI grants you permission to use these resources only for development of an application that uses the TI products described in the resource. Other reproduction and display of these resources is prohibited. No license is granted to any other TI intellectual property right or to any third party intellectual property right. TI disclaims responsibility for, and you will fully indemnify TI and its representatives against, any claims, damages, costs, losses, and liabilities arising out of your use of these resources.

TI's products are provided subject to [TI's Terms of Sale](#) or other applicable terms available either on [ti.com](https://www.ti.com) or provided in conjunction with such TI products. TI's provision of these resources does not expand or otherwise alter TI's applicable warranties or warranty disclaimers for TI products.

TI objects to and rejects any additional or different terms you may have proposed.

Mailing Address: Texas Instruments, Post Office Box 655303, Dallas, Texas 75265
Copyright © 2023, Texas Instruments Incorporated