



GHT21-0960-1

Antenna Datasheet

TITLE : AN010860C00 SERIES
AN010860C00 シリーズ

1. 特徴 Features

- スマートメータ LPWA 等向け 860 MHz アンテナ
860 MHz antenna for smart meter, LPWA, etc.
- 小型 Compact size
- 高効率 High efficiency
- 表面実装部品 Surface mount device
- エンボスリール梱包 Embossed reel package

2. 品名 Product name

単品 Single unit: AN010860C00

1700 個パッケージ 1700-piece package: AN010860C00R1700

3. 形状、寸法と重量 Shape, dimensions and weight

3.1. 形状 Shape

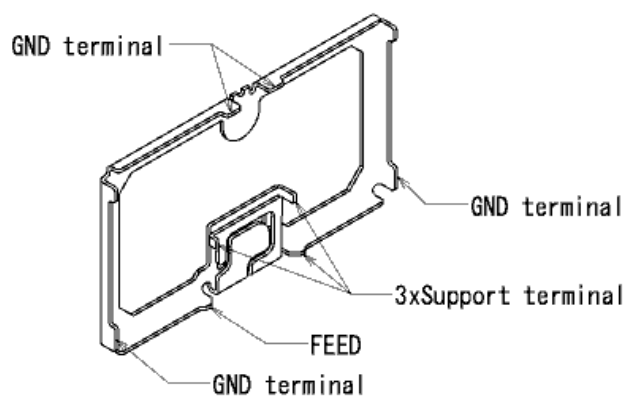



3.2. 寸法 Dimensions

30 (width) × 16.9 (depth) × 1.9 (height) mm

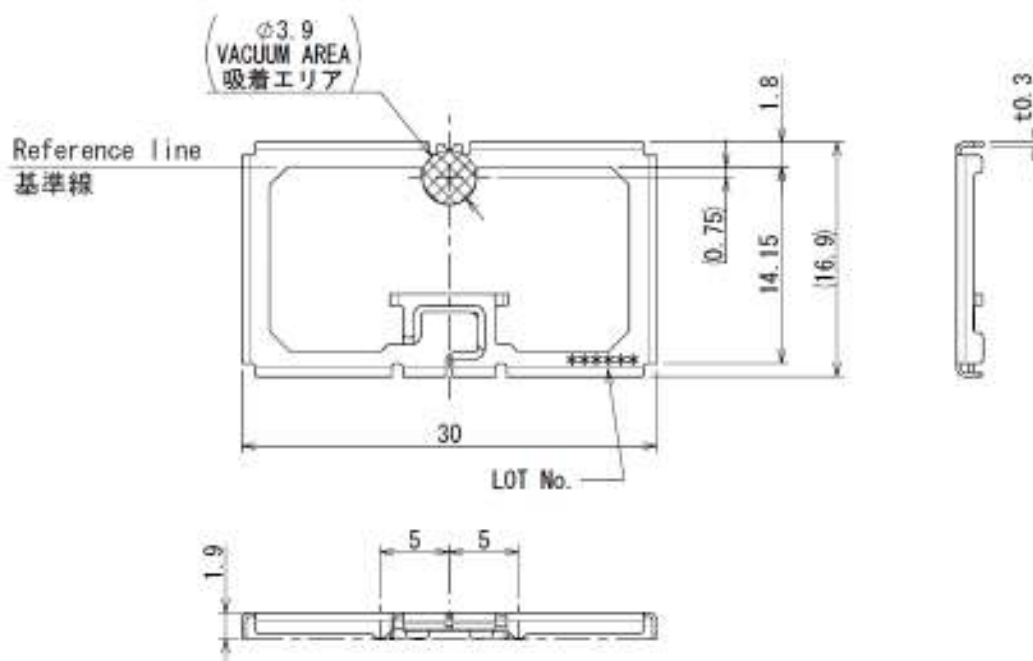

3.3. 重量 Weight

0.75 g (typical)

3.4. めっき Plating

なし None

3.5. 方式 Type

スプリットリング Split ring

3.6. 材料 Material

銅合金 Copper alloy

4. 高周波特性 RF characteristics

4.1. 周波数帯域 Frequency range

863– 870 MHz

4.2. インピーダンス Impedance

50 Ω

4.3. Voltage standing wave ratio (VSWR)

100 x 70 mm の標準基板実装時の VSWR 特性例

VSWR characteristics of the antenna on a 100 x 70-mm reference board

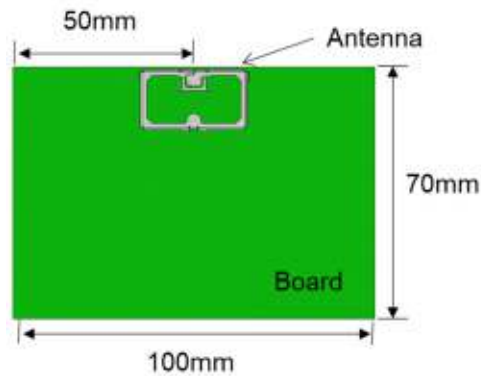

VSWR < 2.5 (frequency range: 863 – 870 MHz)

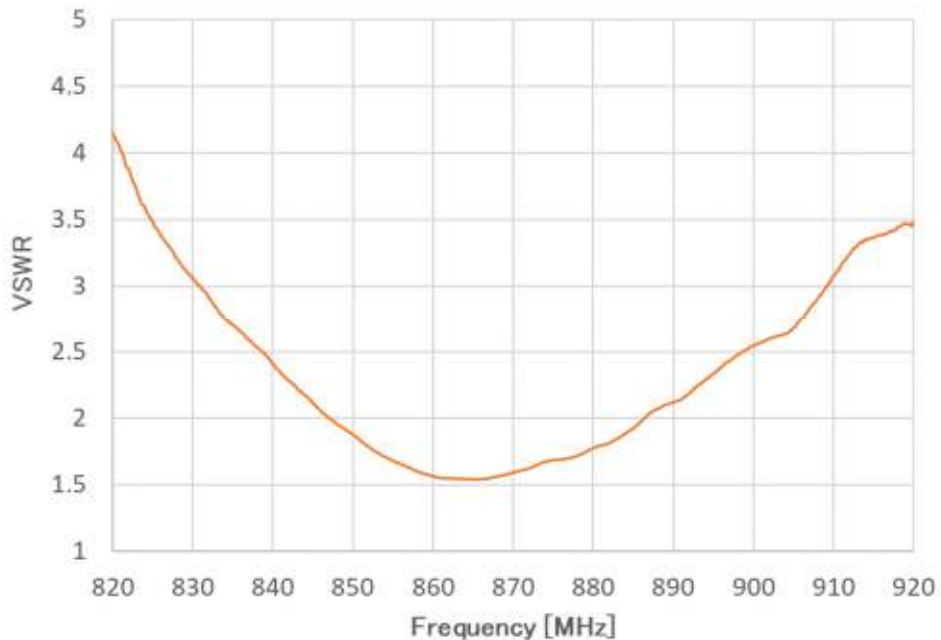



4.4 放射効率 Radiation efficiency

100 x 70 mm の標準基板実装時の放射効率特性例、ケーブル・配線損を除く

Radiation efficiency of the antenna mounted on a 100 × 70-mm reference board (excluding cable and feeder-line losses)

Radiation Efficiency > 85 % (frequency range: 863 – 870 GHz)

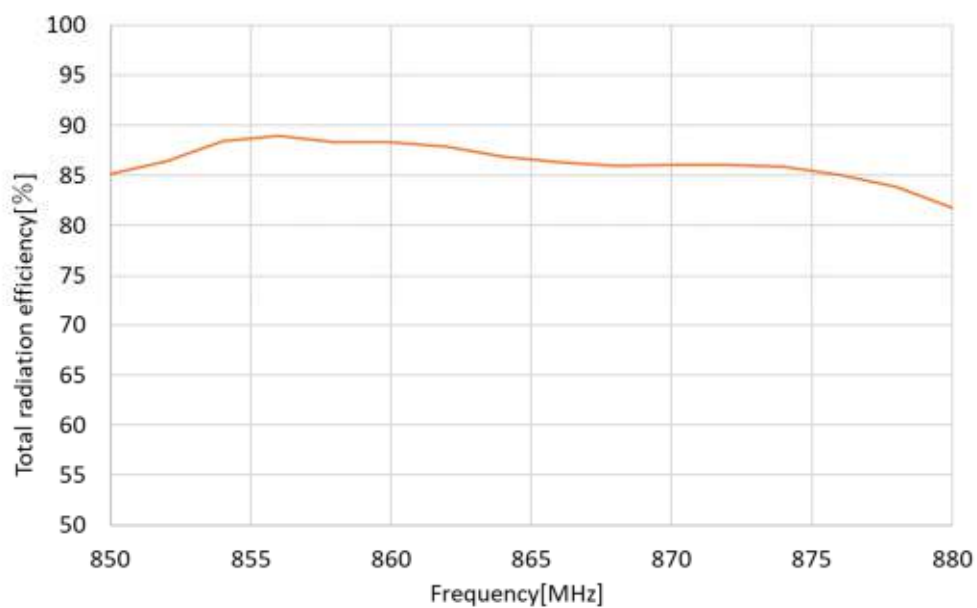

4.5 放射パターン Radiation pattern

100 x 70mm の標準基板実装時の放射パターン特性例

Radiation pattern of the antenna mounted on a 100 × 70-mm reference board

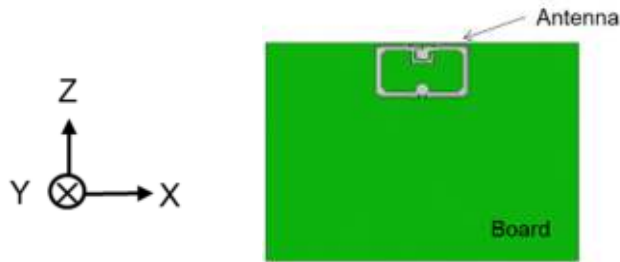

Radiation pattern @865 MHz

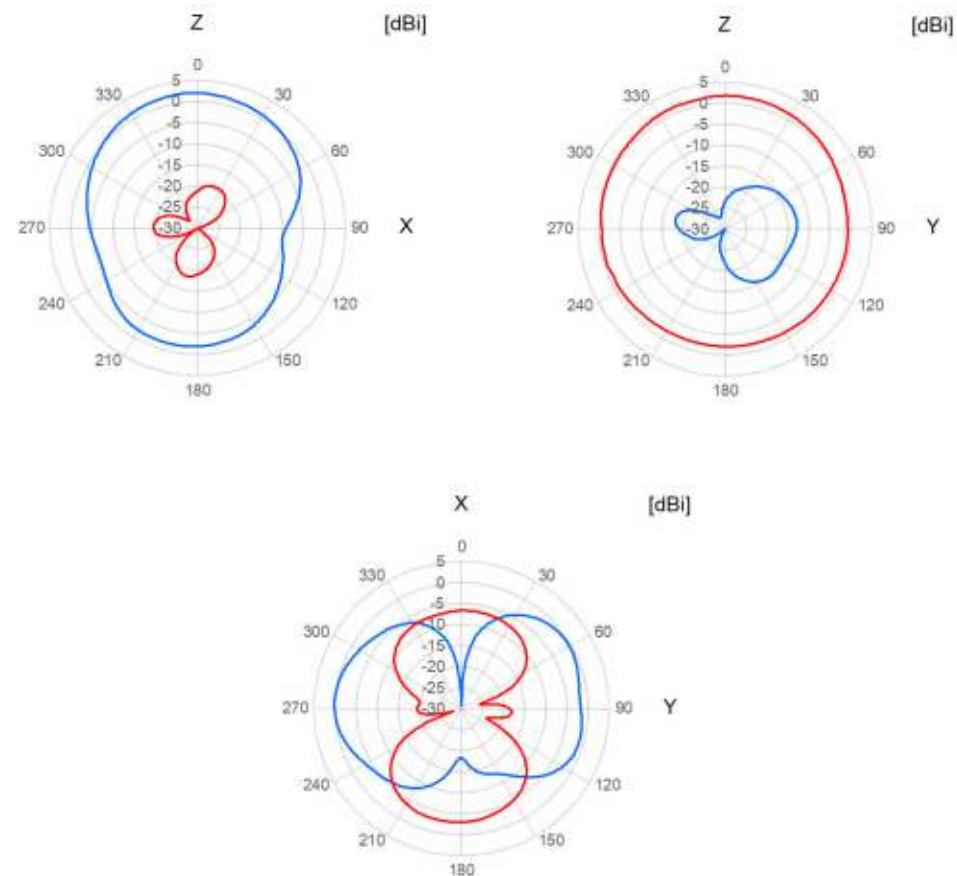

青線 Blue line: 水平偏波 horizontal polarization

赤線 Red line: 垂直偏波 vertical polarization

Peak gain of the main polarization component in the ZX, ZY and XY planes

Frequency [MHz]	Peak gain [dBi]
865	2.14

5. 環境条件 Environmental conditions and reliability

5.1. 使用温度範囲 Operating temperature range

-40 °C to +125 °C

5.2. 保存条件 Storage conditions

IEC 61760-2

保存温度 Stock temperature range

+5 °C to +40 °C

相対湿度 Relative humidity

10 % to 75 %

6. 推奨ランドパターンおよび推奨基板 Recommended land pattern and reference board

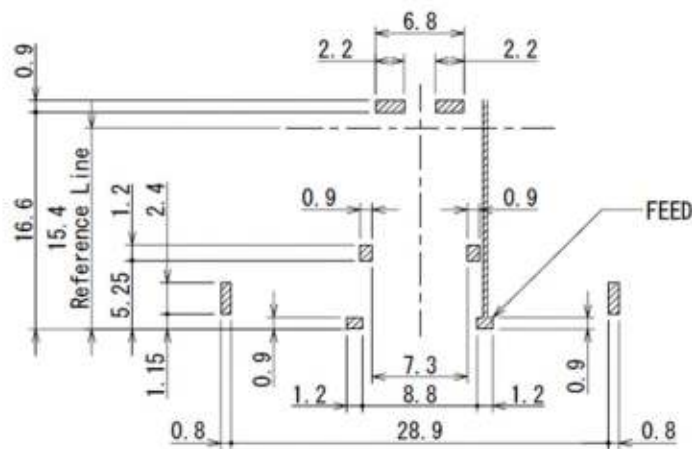

Recommended land pattern

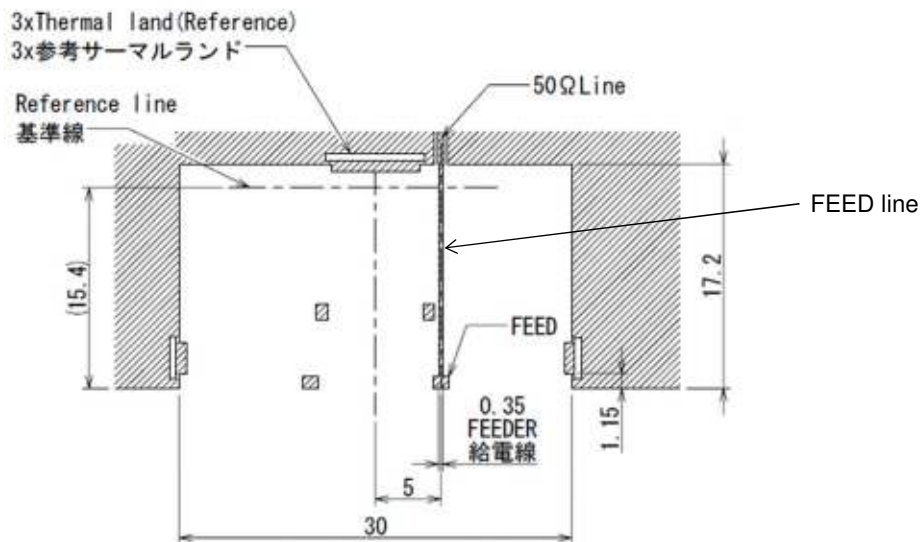

Reference board pattern (board thickness: 1.6 mm)

7. 推奨リフロー温度プロファイル Recommended reflow temperature profile

	温度 Temperature	加熱時間 Heating time
予備加熱 Preheating temperature	180 to 200 °C	120s (max.)
本加熱 Main heating temperature	Above 220 °C	50s (max.)
ピーク温度 Peak temperature	250 °C (max.)	-

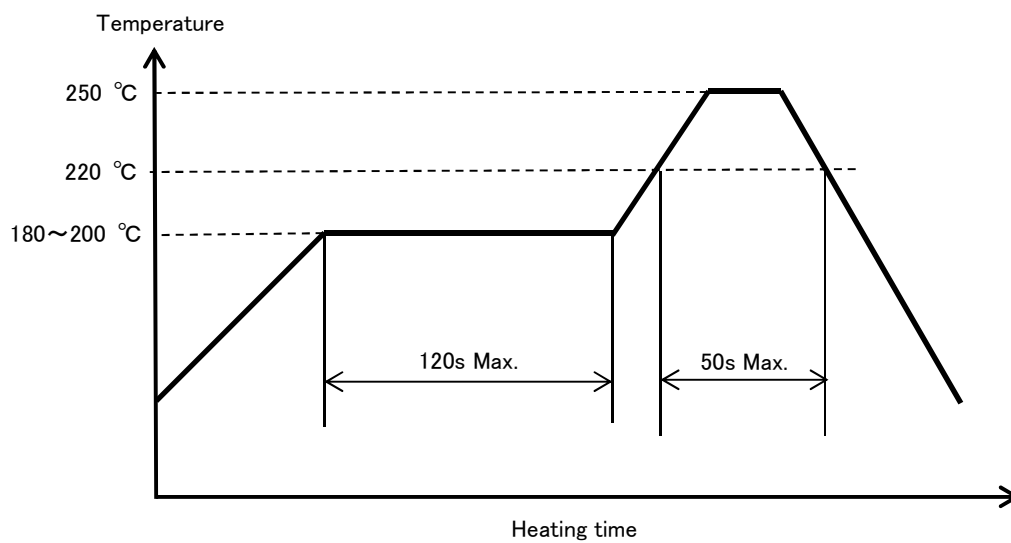

8. 梱包 Packaging

8.1. 梱包数量 Package quantity: 1,700 (pieces / reel)

8.2. エンボスリール寸法 Embossed reel dimensions

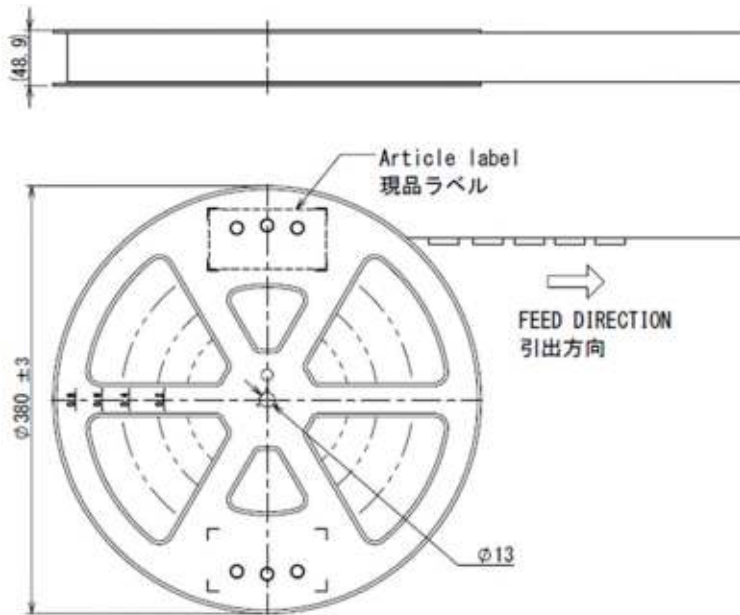

8.3. テープ寸法 Tape dimensions

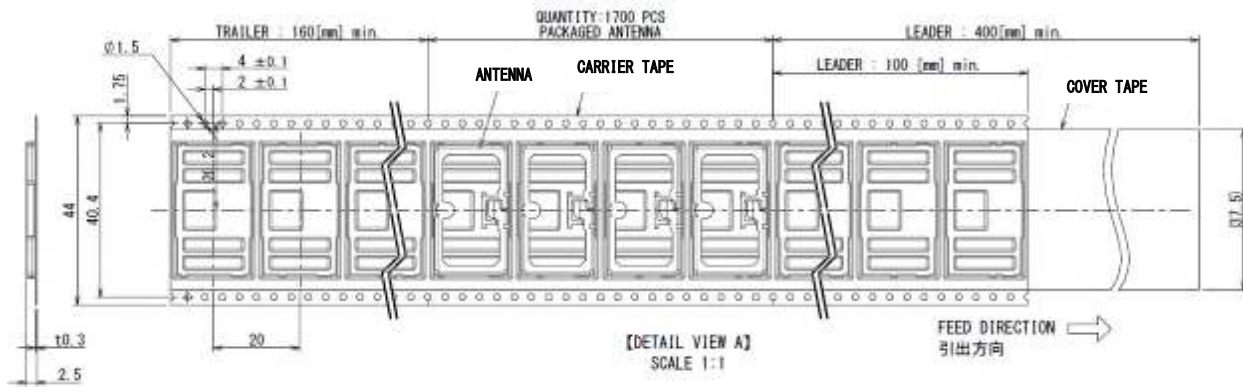



改版履歴 Revision history

文書番号 Document number	日付 Date	改版 Revision
GHT21-0960	16 Jul. 2021	初版 Initial version
GHT21-0960-1	08 Oct. 2021	2 版 Revision 2 - 表記の修正 Editorial changes