

TMCM-160

Hardware

**BLDC motor controller/driver module 5A/36V
with RS232 / RS485 and analog interface**



V1.11
August 8th, 2007



Trinamic Motion Control GmbH & Co. KG
Sternstraße 67
D - 20357 Hamburg, Germany
www.trinamic.com

Contents

1	Features.....	3
2	Life support policy.....	4
3	Outer Description	5
3.1	Pinning.....	5
3.2	Dimensions.....	7
3.3	Connectors.....	7
3.4	Application Environment.....	7
4	Operational / Limiting Ratings.....	8
4.1	Power supply requirements	8
5	Functional description.....	9
5.1	General Functions (explore using the Windows based demo software).....	9
5.2	Options for stand alone operation.....	9
5.3	Evaluation Version – Additional Features.....	9
5.4	LEDs - Temperature, Current and Voltage monitoring	9
5.5	Under voltage behavior	10
5.6	Demonstration Application.....	10
5.7	Programmable motor current limit	10
5.8	Parameterizing the PID velocity regulator	11
5.9	Parameterizing the positioning algorithm.....	12
5.10	Restoring factory default settings.....	12
6	Revision History.....	13
6.1	Documentation Revision.....	13
6.2	Firmware Revision.....	13
7	References	13

List of Figures

Figure 3.1:	Pinning.....	5
Figure 3.2:	Dimensions.....	7
Figure 3.3:	Application Environment.....	7
Figure 5.1:	PID velocity regulator parameters.....	11
Figure 5.2:	Parameterizing the positioning algorithm.....	12

List of Tables

Table 1.1:	Order codes.....	3
Table 3.1:	Pinning of supply, motor and hall connector	5
Table 3.2:	Pinning of I/O connector	6
Table 4.1:	Operational / Limiting Ratings	8
Table 5.1:	Options for stand alone operation	9
Table 5.2:	LEDs - Temperature, Current and Voltage monitoring function.....	9
Table 6.1:	Documentation Revision	13
Table 6.2:	Firmware Revision	13

1 Features

The TMCM-160 is a controller / driver module for general Brushless DC motor applications. It integrates velocity and torque control as well as a hall sensor based positioning mode. The position resolution depends on the motor, i.e. a standard 8 pole motor gives a motor axis resolution of 15 degrees. The module can be used in stand alone operation or remote controlled via a RS232 or RS485 interface (ordering option). Its small form factor (50 x 92 mm²) allows for integration onto a user board as a plug-on module or for panel mounting, by connecting flat ribbon cables to the two 2x13 2.54mm standard header connectors. A version with screw terminal connectors is available (TMCM-160-EvalBoard).

Its integration into the TRINAMIC family of stepper motor controllers makes it easy to choose either a stepper motor or a BLDC motor or any combination for an application.

Applications

- Constant velocity and torque limited drives
- Positioning applications with automatic ramp generation
- Remote controlled (RS232 or RS485) or stand-alone operation (0 – 10V signal)
- Plug-On module or panel mount operation
- Very compact multi-axis drives (integrate several modules on a single base board)

Motor type

- Block commutated 3 phase BLDC motors with hall sensors
- Motor power from a few Watts to 180W
- Motor velocity up to 100,000 RPM (electrical field)
- 12, 24 or 36V nominal motor voltage (or any value in between) (ask for 48V option)
- Coil current up to 3A nominal, 5A with forced cooling (up to 8.5A current for short time)

Highlights

- High-efficiency operation, low power-dissipation
- Typical Supply voltage 14V – 36V (ask for 48V option)
- Integrated Protection: Overload and overtemperature, reverse polarity on EVAL board.
- Supports the TRINAMIC TMCL protocol and the TMCL software environment for parameterizing
- On the fly alteration of motion parameters (e.g. position, velocity, acceleration)

Other

- Two 2-row 2.54mm connectors
- ROHS compliant
- Size: 50x92mm²

Order code	Description
TMCM-160 (-option)	BLDC module
TMCM-160 Evalboard	BLDC evaluation module with screw terminals
TMCM-160 EvalKit	BLDC evaluation module + motor + cables
Option	Host interface
232	RS232 interface (standard version)
485	RS485 interface

Table 1.1: Order codes

2 Life support policy

TRINAMIC Motion Control GmbH & Co. KG does not authorize or warrant any of its products for use in life support systems, without the specific written consent of TRINAMIC Motion Control GmbH & Co. KG.

Life support systems are equipment intended to support or sustain life, and whose failure to perform, when properly used in accordance with instructions provided, can be reasonably expected to result in personal injury or death.

© TRINAMIC Motion Control GmbH & Co. KG 2005

Information given in this data sheet is believed to be accurate and reliable. However no responsibility is assumed for the consequences of its use nor for any infringement of patents or other rights of third parties, which may result from its use.

Specifications subject to change without notice.

3 Outer Description

3.1 Pinning

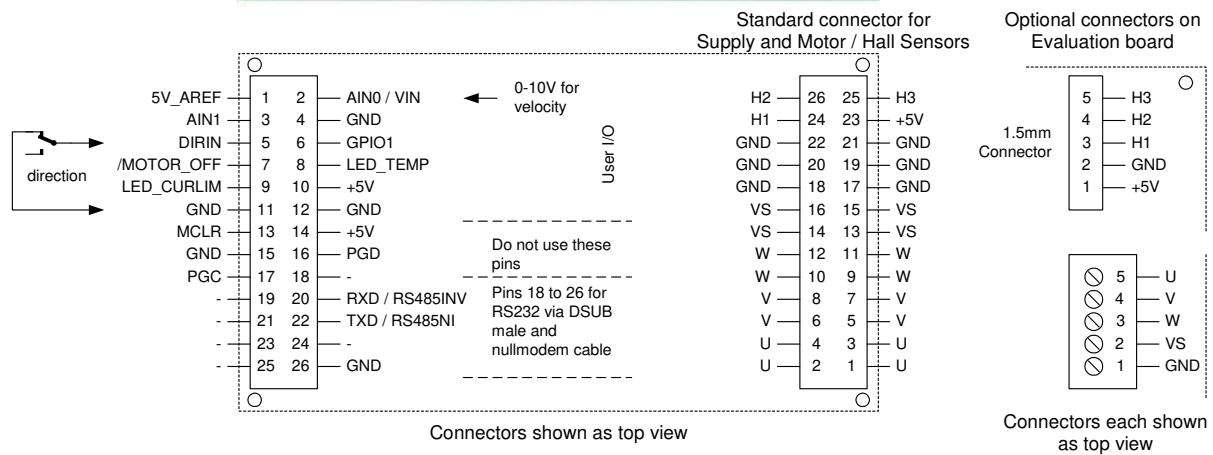
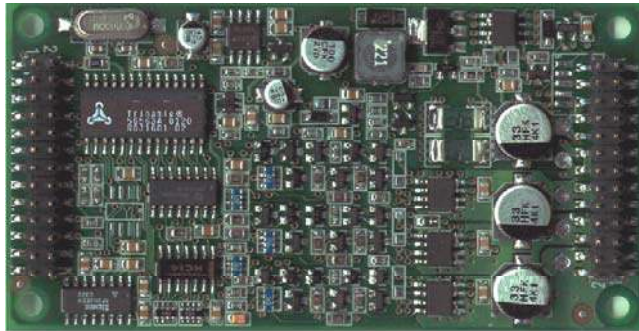

Figure 3.1: Pinning

CAUTION: Since the two connectors of the TCM-160 are similar be careful not to connect the module turned around. When powered up this would damage the module. Figure 3.1 depicts the connectors and their position on the board. The supply, motor and hall connector is next to the three capacitors. Be sure to place the connectors exactly to their opponents. A deviation of only one pin row can damage the module also.

Pin	Name	Function
1 to 12	U, V, W	BLDC motor driver outputs
13 to 16	VS	Positive power supply voltage
17 to 22	GND	Power Ground
23	+5V	5V supply for motor hall sensors
24 to 26	H1, H2, H3	Hall sensor signals (5V TTL input with integrated 10K pull-up resistor to 5V)

Table 3.1: Pinning of supply, motor and hall connector

Pin	Name	Function
1	5V_AREF	5V analog reference as used by the internal DAC. Max. load 0.5mA
2	AINo / VIN	Analog input: Used for velocity control in stand alone operation by supplying external 0 - 10V signal
3	AIN1	Additional analog input. Currently unused – leave open
5	DIRIN	5V TTL input. Tie to GND to inverse motor direction, leave open or tie to 5V otherwise.
6	GPIO1	Starting from Version 1.02: This pin outputs a tacho impulse, i.e. toggles on each hall sensor change
7	/MOTOR_OFF	Emergency stop. Tie this pin to GND to stop the motor (same as Motor Off switch on PCB). The motor can be restarted via the interface, or by cycling the power supply.
8	LED_TEMP	5V TTL output: Toggling with 3Hz when temperature pre-warning threshold is exceeded, high when module shut down due to overtemperature.
9	LED_CURLIM	High, when module goes into current limiting mode
10, 14	+5V	5V supply as reference for external purpose
11, 12, 26	GND	GND reference
20	RXD / RS485INV	RXD signal of module for RS232 communication (RS232 version) Inverting RS485 signal (RS485 version)
22	TXD / RS485NI	TXD signal of module for RS232 communication (RS232 version) Non-inverting RS485 signal (RS485 version)
All other pins		Leave all other pins unconnected!

Table 3.2: Pinning of I/O connector

3.2 Dimensions

92mm*50mm*8.3mm (height measured from PCB to highest part on PCB connector side, parts on top side not included, since these are just for evaluation purpose)

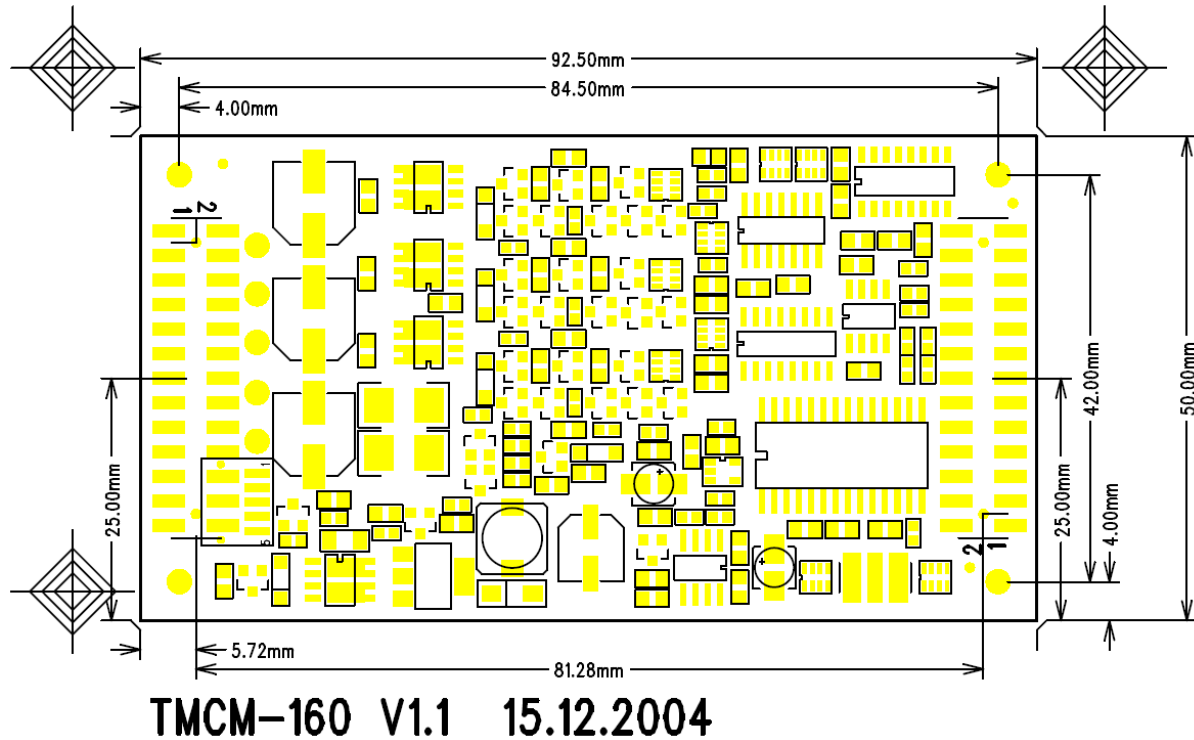

Figure 3.2: Dimensions

3.3 Connectors

Hall sensor: JST1.5mm type: S5B-ZR-SM2-TF (only on EvalBoard)
 Board-Plug on connectors: 2.54 mm two-row Header

3.4 Application Environment

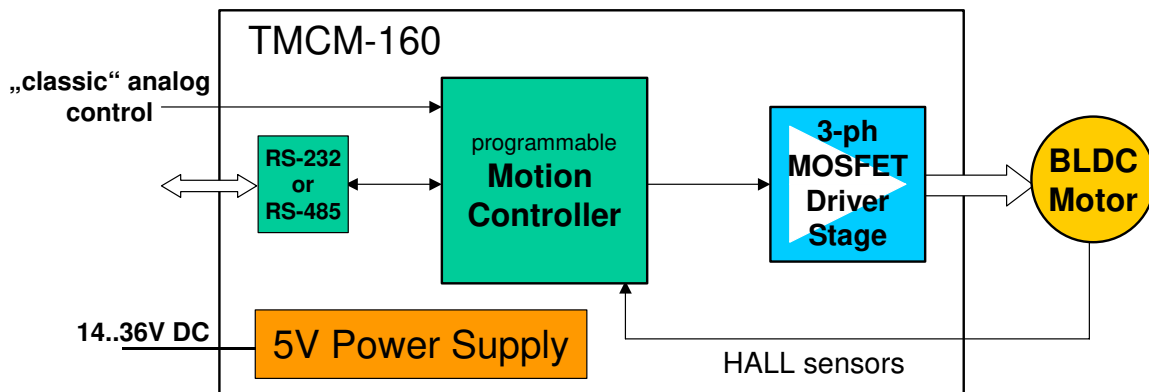

Figure 3.3: Application Environment

4 Operational / Limiting Ratings

The operational ratings show the intended / the characteristic range for the values and should be used as design values. An operation within the limiting values is possible, but shall not be used for extended periods, because the unit life time may be shortened. In no case shall the limiting values be exceeded.

Symbol	Parameter	Min	Typ	Max	Unit
V_S	Power supply voltage for operation	9.0*)	14 - 36	40.0	V
I_S	Power supply current	0.04		I_{MOT}	A
P_{ID}	Module idle power consumption		1.2		W
V_5	5 Volt (+8%) output external load (hall sensors plus other load)			30	mA
V_{5A}	5 Volt (+8%) analog reference output external load			0.5	mA
I_{MC}	Continuous Motor current at V_{MF}		0 - 3	5	A
I_{MP}	Short time Motor current in acceleration periods It is not recommended to set motor current above 6A!		0 - 6	8.5	A
I_{MPP}	Peak coil output current for 100ms			20	A
V_I	Logic input voltage on digital / hall sensor inputs	-0.3		V_{CC+} 0.3	V
V_O	Logic output current on digital outputs (5V CMOS output)			10	mA
V_{IA}	Analog input voltage	-24	0 - 10	24	V
f_{CHOP}	Chopper frequency		20		kHz
E_x	Exactness of voltage and current measurement	-8		+8	%
T_{SL}	Motor output slope (U, V, W)		100		ns
T_O	Environment temperature operating	-25		+70	°C
T_{OF}	Environment temperature for operation at full specified current (air flow might required, depending upon motor / voltage)	-25		+60	°C
T_{board}	Temperature of the module, as measured by the integrated sensor.		<100	125	°C

Table 4.1: Operational / Limiting Ratings

*) At supply voltages below 12V, maximum motor current linearly decreases down to about 0.5A at 9V. To be sure to be outside this area when using the EVALboard, use at least 13V supply voltage, due to voltage drop in the reverse polarity protection.

4.1 Power supply requirements

The power supply should be designed in a way, that it supplies the nominal motor voltage at the desired maximum motor current. In no case shall the supply value exceed the upper / lower voltage limit. To be able to cope with voltage which might be fed back by the motor, the supply should provide a sufficient output capacitor, additionally a 39V suppressor (zener-)diode may be used.

5 Functional description

5.1 General Functions (explore using the Windows based demo software)

The TMC160 module can either be remote controlled via the PC demonstration software or a user specific program, or it can be controlled by an analog voltage (stand alone mode). The function of the stand alone mode can be modified by the user by writing initialization values to the on-board EEPROM, e.g. a maximum rotation velocity, motor current limit and rotation direction. **For more detailed software information refer to the TMC160 BLDC Module – Reference and Programming Manual (7).**

5.2 Options for stand alone operation

Mode	Functionality	Software settings
PWM control	Motor PWM controlled by the analog input VIN. Motor direction controlled by DIR in pin.	Remote control flag = 0 Power on velocity = 0
PID enforced velocity	Maximum motor velocity v_{max} set via software. This velocity is scaled by VIN pin voltage and enforced by the PID velocity regulator.	Remote control flag = 0 Power on velocity = v_{max}
Constant velocity	Desired motor velocity v set via software	Remote control flag = 1 Power on velocity = v

Table 5.1: Options for stand alone operation

In all modes, the motor torque is limit by the maximum current setting. The polarity of the DIR pin can be inverted by the direction input reverse flag setting.

5.3 Evaluation Version – Additional Features

The evaluation version comes equipped with a screw terminal connector for the motor and for the supply. The hall sensor connector is a 5 pin 1.5mm JST type, which directly fits to a NMB motors. An emergency stop switch as well as indicator LEDs are included on the board. An integrated potentiometer allows velocity setting in the stand-alone mode. To use the external 0-10V input, turn this potentiometer to zero velocity (right turn).

5.4 LEDs - Temperature, Current and Voltage monitoring

LED / Output	Action	Meaning
Current Limit	Blink	The current limit LED blinks upon under voltage switch off
Current Limit	On / Flicker	Motor PWM is reduced due to exceeding the set motor current limit
Temperature Warning	Blink	The power stage on the module has exceeded a critical temperature of 100°C. (Pre-warning)
Temperature Warning	On	The power stage on the module has exceeded a critical temperature of 125°C. The motor becomes switched off, until temperature falls below 115°C. The measurement is correct to about +/-10°C

Table 5.2: LEDs - Temperature, Current and Voltage monitoring function

5.5 Under voltage behavior

- The motor is switched on, if the supply voltage exceeds 9.0V
- The motor is switched off, if the supply voltage falls below 8.5V
- The current reduction due to low supply voltage may inhibit starting-up of the motor
- EVALboard: Motor current is reduced to a lower value, if the voltage is below 12V. If motor load is too high, the module goes into under voltage switch off again. This is due to the voltage drop in the reverse polarity protection. Motor current is additionally limited at low supply voltages: 0.5A at 9V and linear increasing to 4A at 12V. To be sure to be outside this area, use at least 13V supply voltage, due to voltage drop in the reverse polarity protection.

5.6 Demonstration Application

You can use the Demonstration application for the TMCM-160 to set the module into operation. Please remark, that you first should as a first step switch the module to remote controlled mode. You can use the TRINAMIC TMCL IDE to update the modules firmware and to test / set all of the modules parameters. If your motor shows instable behavior, you have to tune the PID regulator values. In order to do this, you need to use the TMCL IDE.

5.7 Programmable motor current limit

The motor current limiting function is meant as a function for torque limiting, and for protection of motor, power supply and mechanics.

Whenever the pre-programmed motor current is exceeded in a chopper cycle, the TMCM-160 calculates a reduced PWM value for the next chopper cycle. New values are calculated 100 times a second. The response time of the current regulation can be set using the parameter "current regulation loop delay":

A value of zero means, that in every 100Hz period, the current correction calculation is directly executed and the resulting PWM value is taken. A higher current loop delay acts like a filter for the current. The higher the delay value, the slower the current loop response time. A value of 5 (default) leads to a current regulation response time of about 60 ms. On the mechanical side, a higher value simulates a higher dynamic mass of the motor.

$$t_{LIM} = 1 / (1 / 3s + 1 / (10ms * (1+x_{CRLD})))$$

x_{CRLD} is the current regulation loop delay parameter, t_{LIM} the resulting time for an 1/e response.

The actual current regulation time may be faster, depending on the PID settings.

Attention: *Please be careful, when programming a high value into the current regulation loop delay register or if you want to work above the modules' rated motor current: The motor current could reach a very high peak value upon mechanical blocking of the motor. If the short time current is not limited to a maximum of about 20A, this could destroy the unit.*

- The current measurement can not detect currents below about 200-300mA. If the current limit is set to a too low value, the motor may become continuously switched off.
- The current limiting function is not meant as a protection against a hard short circuit.
- The maximum motor current should never be set above the rated short time motor current, because the current regulator can not operate correctly, if the current limit is set too close to the measurement range limits.

5.8 Parameterizing the PID velocity regulator

The motion control commands (TMCL_ROL, TMCM_ROR, TMCL_MVP) use a PID regulator for velocity control. The PID regulator has to be parameterized with respect to a given motor in a given application. The default parameter set of the PID regulator covers a range of motors suitable for the TMCM-160 module, and typically works stable up to 15000 rpm maximum motor velocity. However, for slower motors, the response time with this parameter set may become quite slow.

The PID regulator uses four basic parameters: The P, I and D values, as well as a timing control value. The timing control value (PID regulation loop delay) determines, how often the PID regulator is evoked. It is given in multiple of 10ms:

$$t_{PIDDELAY} = X_{PIDRLD} * 10ms$$

X_{PIDRLD} is the PID regulation loop delay parameter, $t_{PIDDELAY}$ is the resulting delay between two PID calculations

The PID parameters are divisors, e.g. use a higher value, to get less influence from the parameter. To parameterize for a given motor, first modify the P parameter, starting from a high value and going to a lower value, until fastest response with minimum oscillation is given.

After that, do the same for the I parameter. Now, modify the D parameter in the same way. It will damp part of the oscillations of the other parameters, too.

As a thumb-rule, you can set the P-parameter to a starting value, such that:

$$P\text{-param} = (\text{Maximum actual RPM of the motor at 100\% PWM}) * 0.15$$

The module uses the internally calculated velocity value (1/4 of electrical RPM value) as input into the PID regulator (see schematic).

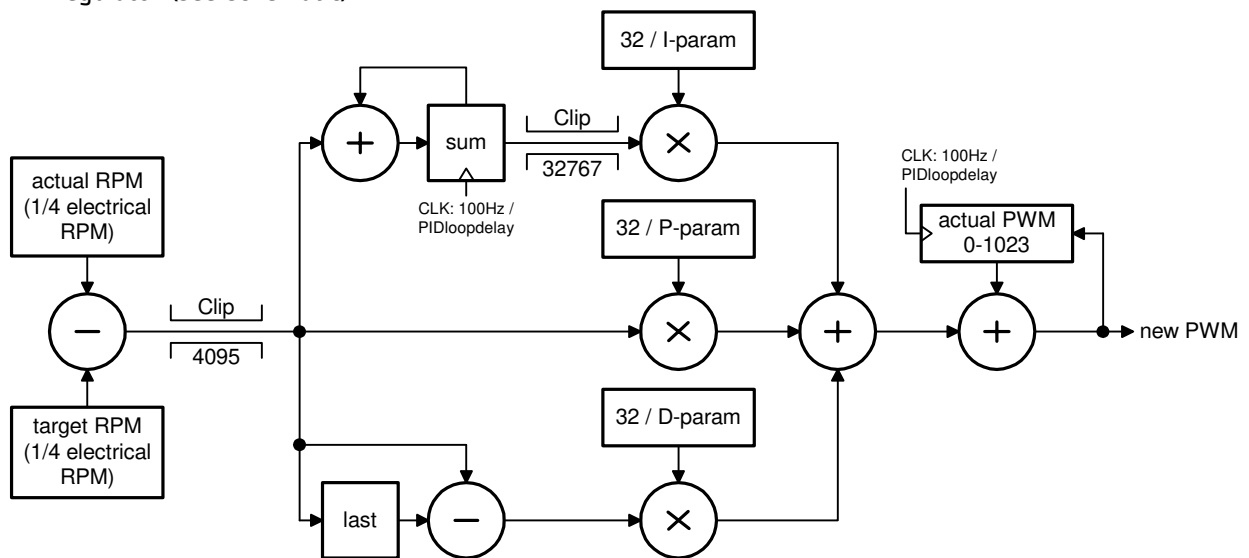

Figure 5.1: PID velocity regulator parameters

Default values:

P-param = 2400

I-Param = 150

D-Param = 600

$X_{PIDRLD} = 2$

5.9 Parameterizing the positioning algorithm

The module supports a positioning based on the motor's hall sensor information. Please refer to the schematic for the required set of parameters.

You can optimize the parameter set in your application to get a good positioning accuracy and a fast positioning speed:

1. Select the maximum positioning speed as desired
2. Choose a minimum positioning speed, that allows a fast stop of the motor
3. Set the MVP_slow_down_distance in a way, that the motor slows down to the min_pos_speed in this area (dotted line)
4. Choose the active brake velocity as allowable for your application
5. Set MVP_target_reached_distance to the value, which gives a stop as near as possible to the target position

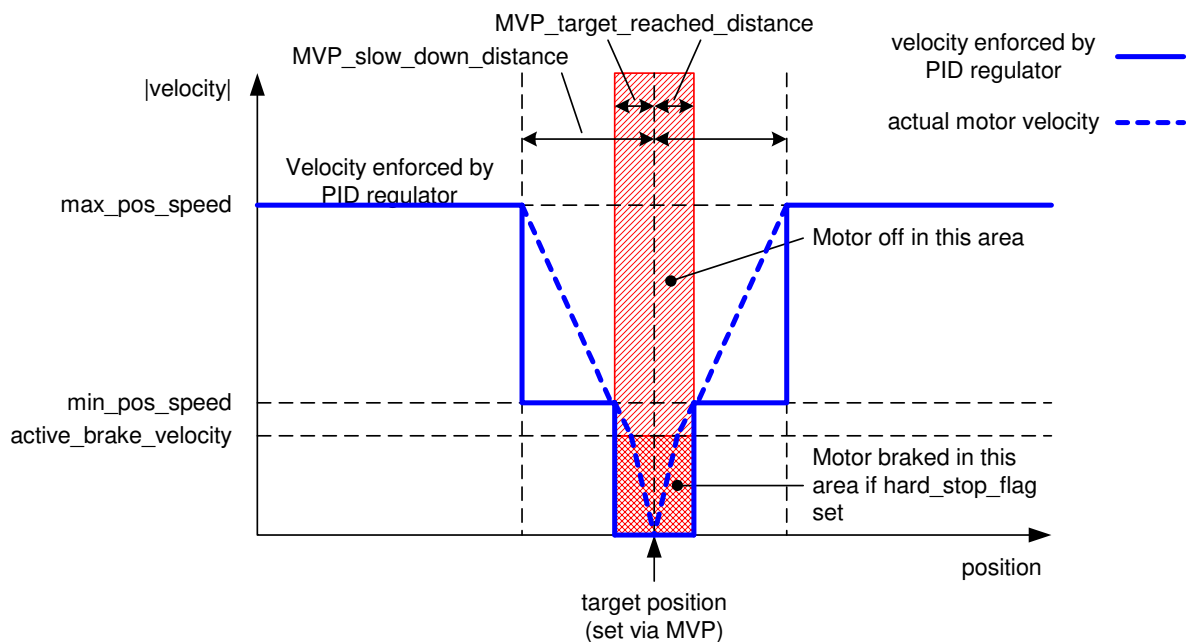

Figure 5.2: Parameterizing the positioning algorithm

5.10 Restoring factory default settings

The module stores user settings in an on-board EEPROM. You can restore the factory values, by setting and storing a 255 to the current limit parameter. Upon next power on, all EEPROM values are loaded with the default settings. However, this also clears the temperature measurement calibration, which should be recalibrated before operating the device near its temperature limits.

6 Revision History

6.1 Documentation Revision

Version	Comment	Description
1.07	New Version	Revised Version
1.08		
1.09	Appl. Env.	Added application environment and optical changes
1.10	HW change	Reverse protection on EVALboard only
1.11	Pinning	Clarification of pinning to avoid module damage

Table 6.1: Documentation Revision

6.2 Firmware Revision

Version	Comment	Description
1.01	Initial Version	Bug in current regulation algorithm: Instable operation with settings above 4.6A
1.02	Added RS485, Tacho output	Added baud rate switching Added RS485 interface Fixed current regulation bug GPIO ₁ provides for a hall sensor derived tacho signal Analog control input now uses 10 bit resolution for PWM / velocity control
1.03	Invert Hall	Added possibility for inversion for hall sensor signals Corrected velocity readout when motor is turned by external force
1.04	Disable Stop switch	Added disable stop switch function
1.05	RS485	Corrected sent back address
1.06	Corrected position counter	In older firmware versions, the position counter sometimes loses a step, which may add up during longer motions to 1/1000 of total count.

Table 6.2: Firmware Revision

7 References

[TMCL] TMCL Manual, www.trinamic.com
 TMCM BLDC Module Reference and Programming Manual, www.trinamic.com